

OFFICE OF RESEARCH · AMERICAN COUNCIL ON EDUCATION

The American Freshman: National Norms for Fall 1971

STAFF OF
THE OFFICE OF RESEARCH



VOL. 6 NO. 6 · 1971

AMERICAN COUNCIL ON EDUCATION

LOGAN WILSON, *PRESIDENT*

The American Council on Education, founded in 1918, is a council of educational organizations and institutions. Its purpose is to advance education and educational methods through comprehensive voluntary and cooperative action on the part of American educational associations, organizations, and institutions.

The Council's Office of Research was established in 1965 to assume responsibility for conducting research on questions of general concern to higher education. *ACE Research Reports* are designed to expedite communication of the Office's research findings to a limited number of educational researchers and other interested persons.

OFFICE OF RESEARCH STAFF

Don Abshire, <i>Programmer</i>	Lisa Haldane, <i>Research Assistant</i>
Richard Anderson, <i>Programmer</i>	Jerome Karabel, <i>Research Assistant</i>
Alexander W. Astin, <i>Director</i>	Melvena Kelley, <i>Secretary</i>
Alan E. Bayer, <i>Associate Director</i>	Laura Kent, <i>Editor</i>
Ann Bisconti, <i>Research Assistant</i>	Margo King, <i>Secretary</i>
Barbara Blandford, <i>Project Director, Higher Education Panel</i>	Shawne Lampert, <i>Programmer</i>
Marilyn Block, <i>Secretary</i>	Terry Mahn, <i>Programmer</i>
John A. Creager, <i>Research Associate</i>	Linda Molm, <i>Research Analyst</i>
David E. Drew, <i>Research Associate</i>	Jack E. Rossmann, <i>Research Associate</i>
Diane Dutton, <i>Research Assistant</i>	Jeannie Royer, <i>Secretary</i>
Jeffrey Dutton, <i>Chief, Data Processing</i>	Charles Sell, <i>Associate Chief, Data Processing</i>
Helen Frazier, <i>Computer Operator</i>	Joan Trexler, <i>Research Assistant</i>

ACE RESEARCH ADVISORY COMMITTEE

Nicholas Hobbs, *Chairman*
Provost, Vanderbilt University

Jessie Bernard Research Scholar Honoris Causa Pennsylvania State University	Edmond P. Gordon Professor and Chairman, Department of Guidance Teachers College Columbia University
Allan M. Cartter Chancellor New York University	William Sewell Professor, Department of Sociology University of Wisconsin
John G. Darley Chairman, Department of Psychology University of Minnesota	Carolyn Thornell Assistant Professor, Department of Sociology Columbia University
N. L. Gage Professor of Education and Psychology Stanford University	Ralph W. Tyler Acting President Social Science Research Council
Richard C. Gilman President Occidental College	Dael Wolfle Graduate School of Public Affairs University of Washington

THE AMERICAN FRESHMAN: NATIONAL NORMS FOR FALL 1971

Staff of the Office of Research

American Council on Education

ACE RESEARCH REPORTS

Vol. 6, No. 6

December, 1971



Table of Contents

		<u>Page</u>
	List of Tables	
	Acknowledgements	
I	Introduction.....	1
II	The Statistical Universe of Institutions....	4
III	Weighting Procedures.....	8
IV	The Student Information Form.....	11
V	1971 National Norms.....	14
VI	Precision of the Normative Data and Their Comparisons.....	15
VII	References.....	19
VIII	1971 National Norms	
	A. Type of Institution and Type of Control for:	
	1. Men.....	23
	2. Women.....	31
	3. All Freshmen.....	39
	B. Geographic Region.....	47
	C. All Freshmen.....	55
IX	APPENDIX A: Institutions Participating in the ACE Cooperative Institutional Research Program.....	63
X	APPENDIX B: 1971 Student Information Form..	81
XI	APPENDIX C: Coding Scheme for Collapsed Items	
	A. Probable Major Field of Study.....	89
	B. Probable Occupation.....	90
	C. Father's Occupation.....	91

Table of Contents (Continued)

		Page
XII	APPENDIX D: Relationship Between Strati- fication Cell Assignment and Norms Group Inclusion for Institutions in the Norma- tive Sample.....	93
XIII	APPENDIX E: Sample Report Furnished to a Participating Institution.....	97

List of Tables and Figures

A.	1971 Data Bank Population.....	6
1.	1971 ACE Sample and Weights Used in Computing National Norms.....	10
2.	Use of 1971 Student Information Form Items in Earlier Surveys.....	12
3.	Number of Institutions and Students Used in Computing Weighted National Norms for 1971.....	16

ACKNOWLEDGEMENTS

Development of the annual national norms for entering freshmen is entirely a collaborative effort.* Since each member of the Staff of the Office of Research assumed primary responsibility for some key aspect of the total effort, authorship has been credited to the entire research staff.

We should like to take this opportunity to express our appreciation to the entire staff of the INTRAN Corporation. Although this was their first year of processing the forms for the Cooperative Institutional Research Program, and in spite of new complexities and expansion of the program in 1971, they were able to provide efficient, thorough, and expeditious service. We are particularly indebted to Dennis A. Dillon, Gerald F. Koch, Robert C. Meeder, and Gerold B. Westberg of the INTRAN Corporation for their outstanding performance in all phases of the processing of the freshman questionnaires, including the excellent job of quality control in the printing, distribution, and optical scanning of the questionnaires in Minneapolis.

Our continued gratitude is also extended to the students, representatives, and presidents of the institutions cooperating in this sixth year of the Council's Cooperative Institutional Research Program. We are especially indebted to those who participated for the first time in this year's enlarged survey. Without the support and interest of all participants, this project would not have been possible.

*This program was supported in part by Grant GR-100 from the National Science Foundation.



The American Freshman:
National Norms for Fall 1971

This report presents national normative data on characteristics of students entering colleges as first-time freshmen during the early part of the 1971-72 academic year. It is the sixth in a series of annual reports initiated in 1966 as part of the Cooperative Institutional Research Program (CIRP) conducted by the Office of Research of the American Council on Education. The major purpose of this ongoing longitudinal research program is to determine how students are affected by the colleges they attend (Astin et al., 1966). During the past five years, this steadily expanding program has produced much useful information derived from normative, substantive, and methodological research bearing on a wide range of issues in higher education (Creager and Boruch, 1971; American Council on Education, 1971).

Each year, the first step in implementing this longitudinal program consists of a sample survey of freshmen entering the nation's institutions of higher education. These data are then weighted to provide a normative picture of the college freshman population addressed to persons engaged in guidance, counseling, administration, educational research, and manpower planning, and to the general community of students and parents. The survey instrument, the Student Information Form (SIF), is revised

annually to reflect the changing concerns of the academic community and of other users of the resulting information.¹

In previous surveys of entering freshmen, approximately 15 percent of the nation's institutions of higher education were selected by sampling procedures and invited to participate in the program. As the value of being in the program became better known throughout the academic community, many other institutions requested that they be given an opportunity to participate. To accommodate such requests, and to help defray the ever increasing costs of these surveys, the Office of Research decided to invite all institutions that have entering freshman classes and that respond to the U.S. Office of Education's Higher Education General Institution Surveys to participate on a nominal paying basis. A minimum charge, plus a unit rate based on the number of Student Information Forms processed, was assessed. In view of the relatively late decision to invite these additional institutions, the extent of participation has been substantial, more than compensating for the extra effort involved in expanding the survey operations.

Following the design of previous reports in this series, data are reported separately for men and women, for several

¹The data from the Student Information Form also provide initial input information for longitudinal research. Followup surveys of individual students in each cohort year are conducted at various points in time after the initial survey. Results from a one-year followup of 1966 entering freshmen have been published (Bayer et al., 1970). In addition, as an informational service, followup reports on their students have periodically been sent to institutions that participated in earlier years of the CIRP.

types of institutions, and for different regions of the country; in all there are 24 separate norms groups. Although a total of 288,526 entering freshman students at 487 colleges and universities returned data in time to be processed for inclusion in the 1971 survey, the normative data presented in this report are based on 171,509 freshmen entering 326 institutions. The reason for this difference is that certain quality controls and other technical restrictions were imposed on the total sample of participants to derive the normative sample. Specifically, a participating institution was excluded from the normative sample if it failed to carry out either a complete or a representative sampling of its entering freshman class or if it administered the SIF after the first few weeks of classes. The rationale for this exclusion was discussed in a special report on sampling and weighting procedures (Creager, 1968).

The normative data presented in this report were collected by administering the 1971 Student Information Form to freshmen during registration, freshman orientation, or during the first few weeks of classes. The SIF is designed to elicit a wide range of biographic and demographic data, as well as data on the student's high school background, career plans, educational aspirations, financial arrangements, high school activities and behaviors, and current attitudes. Those data meeting the quality requirements have been differentially weighted to

represent the population of entering freshman students at all higher educational institutions in the United States.²

The Statistical Universe of Institutions

The design of the 1971 survey of entering freshmen incorporates some major modifications of the stratification procedure used in previous surveys. The original design, used in the 1966 and 1967 surveys, was modified in 1968 for use in the third, fourth, and fifth surveys in this series. The same general logic and strategy for sampling and weighting procedures to ensure representativeness of the survey data was used in the two former designs and in the present one. The cell structure, as well as the sampling of institutions within cells and of students within institutions, constitutes a complex, mixed-strategy involving the compromise of several technical and logistical considerations.³ The three different designs vary primarily in the definitions of the cells, i.e., in the finer control parameters within the major sections (university, four-year, two-year and predominantly black) of the design.

The major reasons for introducing the changes are: (1) availability of more complete and more appropriate information about

²A distinction should be made between higher education and postsecondary education. Thus, these surveys do not include students in proprietary, special vocational, or semiprofessional institutions; they do, however, include those attending two-year colleges with terminal occupational programs.

³Technical details about this sampling design and the weighting procedures used to correct for the resulting disproportionate sampling of institutions in each cell may be found in the previously mentioned special report (Creager, 1968).

institutions, (2) changes in the institutional structure in higher education, especially differential growth rates by types of institutions, and (3) accumulated experience regarding the participation rates for various kinds of institutions. Moreover, experience indicates that for normative purposes, the compromise between ideal stratification for substantive research purposes and normative purposes should give greater weight to the latter than has been previously employed. In the two-year colleges, where rapid growth has occurred and selectivity and/or affluence data are either unavailable or less relevant, the basis of stratification adopted in the new design is size and mode of control. Minor restratification of the universities introduces mode of control as one of the parameters of this part of the survey design. The new design is shown in Figure A.

As in the previous surveys, the defined population consists of all eligible institutions of higher education listed by the United States Office of Education in its annual Education Directory (USOE, 1970). An institution was considered eligible if it was functioning at the time of the survey and if it had a freshman class of at least 30 students. Thus, institutions requiring undergraduate credits for admission to their first class (for example, some professional schools) and a few very small institutions were excluded. With these exceptions, the defined population comprised all accredited and nonaccredited institutions listed by the Office of Education, whether university, four-year college, or two-year college; at the time of the 1971 survey, these numbered 2,543.

Figure A

1971 Data Bank Population (N = 2543)^a

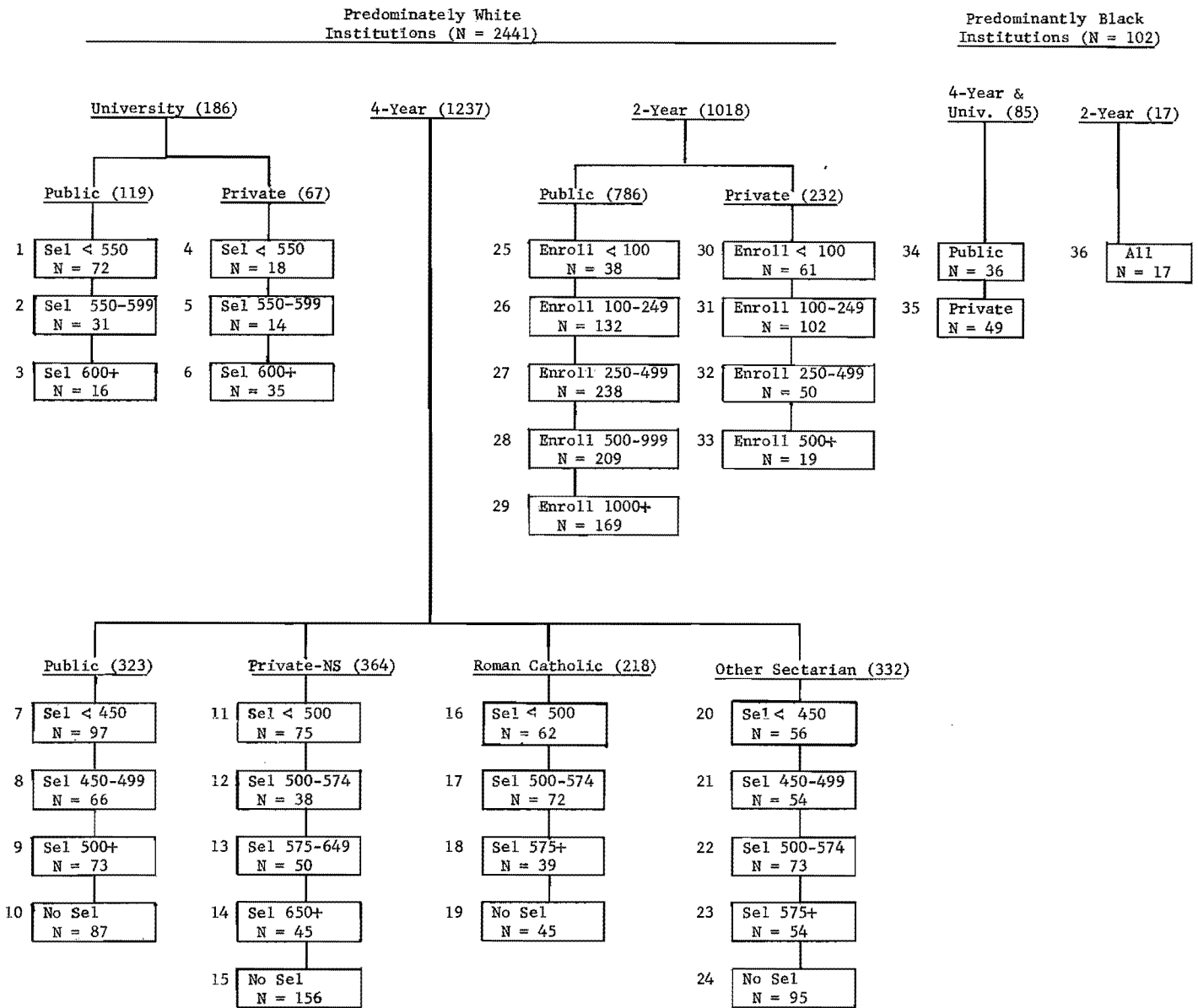

^aSelectivity (Sel), used to define some stratification cells, is described in detail in the 1968 National Norms for Entering Freshmen, Page 3.

Of the 2,543 institutions in the population defined for the survey, 2,432 were invited to participate in the 1971 expanded survey of entering freshmen. These included all institutions participating in previous surveys, plus other institutions listed by the Federation of Regional Accrediting Commissions of Higher Education (1970) as accredited, candidates for accreditation, or correspondents of the accrediting commissions. Of the 2,432 invitees, 562 (23.1 percent) participated in one or more of the earlier surveys, and 1,871 (76.9 percent) were new invitees. A total of 531 (21.8 percent) institutions accepted the invitation to participate. Of the 425 that participated in the 1970 survey, 381 (89.6 percent) accepted again in 1971.

Because of administrative and logistic problems, 44 of the institutions that accepted the invitation to participate were unable to return the completed forms in time for inclusion in the national norms. Thus data were obtained from 487 (91.7 percent) of the institutions that had agreed to participate in the 1971 survey. Appendix A lists all institutions that have participated in the Cooperative Institutional Research Program in any of the six years since its inception and indicates for each institution the current stratification cell assignment, the number of years it has taken part in the CIRP, and its status in the 1971 survey.

As was the case with previous surveys, the national norms for entering freshmen are based only on data from those institutions that are judged to have obtained a reasonably representative

sample of their entering freshmen classes. This judgment is based on the percentage of students in the entering freshman class who completed the 1971 Student Information Form and on information about the manner in which the forms were administered. It was decided to base the 1971 national norms on data provided by 326 of the institutions; this figure includes 254 prior participants and 72 new participants.⁴

Weighting Procedures

Because of disproportionate sampling and participation in the 36 stratification cells, the data obtained from students enrolling at institutions assigned to various cells were differentially weighted. Moreover, the data were adjusted separately by sex to correct for less than 100 percent participation of students within individual colleges. Special care was taken to exclude from the normative sample those students who had transferred into the freshman class from other collegiate institutions.

Table 1 gives information about the institutions included in the 1971 national norms. It shows the number of colleges in each stratification cell and the cell weights applied to each institution's data in computing the national norms. The cell weights, listed in the last two columns of the table for each sex, are the ratios between the number of first-time, full-time

⁴Although each participating institution was provided a complete tabulation of its data, those whose sampling was regarded as unrepresentative were informed that comparisons between their institutional data and the national norms should be made with caution.

freshmen in the eligible population within a given cell and the number of freshmen entering ACE sample institutions in that cell. Because of the expansion of the survey this year, more institutions provided data acceptable for inclusion in the norms; the cell weights are therefore generally smaller than those in prior surveys and fewer cells had to be combined. One fortunate consequence of the smaller cell weights is that the norms are less likely to be influenced by idiosyncrasies in the data from a particular institution.

The cell weights were further adjusted within each institution according to the proportion of the institution's first-time, full-time entering freshmen who completed the questionnaire and who reported their sex on the SIF. Typically, this second weight is close to 1.0; in the case of an institution that administered the form to its entire freshman class, it is exactly 1.0. The final weight applied to the data from each student was the product of this within-institution participation weight and the appropriate cell weight shown in Table 1.⁵

The purpose of these weighting procedures is to adjust the summary data presented in this report so that it is representative

⁵Note that the cell weight shown in Table 1 is a sex-specific constant for each ACE sample institution in a given cell, whereas the within-institution weight is a sex-specific constant for a given institution but varies from one institution to another, depending on how adequately the institution "covered" its entering class. Another type of weight (not shown) is the institutional weight. This weight -- defined as the ratio between the number of institutions in the population within a given cell and the number of participating institutions whose data were used in computing the 1971 national norms -- will be utilized in studies where the institution (rather than the student) is the unit of analysis.

Table 1

1971 ACE Sample and Weights Used in Computing National Norms

Stratification Cell for Sampling		Number of Institutions Participants			Cell Weights ^a Applied to	
		Popu- lation	Total	Used in Norms	Data Collected From Men	Women
<u>Public University</u>						
	Selectivity:					
1.	Less than 550	72	20	7	8.9	9.9
2.	550-599	31	10	5	7.0	6.7
3.	600 or more	16	7	5	3.1	3.4
<u>Private University</u>						
	Selectivity:					
4.	Less than 550	18	8	6	2.5	2.4
5.	550-599	14	5	2	6.9	6.9
6.	600 or more	35	18	7	7.2	9.7
<u>4-Year Public College</u>						
	Selectivity:					
7.	Less than 450	97	10	5	19.2	19.6
8.	450-499	66	13	9	8.8	6.3
9.	500 or more	73	16	11	6.2	15.6
10.	Unknown	87	12	6	15.2	16.0
<u>4-Year Private Nonsectarian</u>						
	Selectivity:					
11.	Less than 500	75	22	13	5.1	4.5
12.	500-574	38	11	8	3.3	3.1
13.	575-649	50	24	20	2.6	2.4
14.	650 or more	45	26	20	2.2	2.7
15.	Unknown	156	17	9	11.2	16.2
<u>4-Year Catholic</u>						
	Selectivity:					
16.	Less than 500	62	17	16	3.9	4.2
17.	500-574	72	20	14	3.5	4.8
18.	575 or more	39	16	12	1.5	2.4
19.	Unknown	45	5	4	19.1	9.9
<u>4-Year Other Sectarian</u>						
	Selectivity:					
20.	Less than 450	56	15	10	4.6	4.6
21.	450-499	54	13	10	6.2	6.5
22.	500-574	73	26	22	3.5	3.8
23.	575 or more	54	23	18	2.5	2.9
24.	Unknown	95	6	5	19.9	16.8
<u>2-Year Public</u>						
	Enrollment:					
25,26,27.	Less than 500	408	28	19	17.0	19.7
28,29.	500 or more	378	36	18	25.2	24.4
<u>2-Year Private</u>						
	Enrollment:					
30,31.	Less than 250	163	21	16	10.3	7.4
32.	250-499	50	9	6	11.8	6.7
33.	500 or more	19	3	3	4.6	14.5
<u>Predominantly Black</u>						
34.	Public 4-year	36	16	9	4.6	4.9
35.	Private 4-year	49	12	9	6.5	4.7
36.	2-year	17	2	2	8.8	5.6

^aRatio between the number of 1970 first-time, full-time students enrolled in all colleges and the number of first-time, full-time students at colleges in the ACE sample.

of all first-time, full-time students entering institutions of higher education in the fall of 1971. It is important to note that the SIF was completed by entering freshmen and thus the data reflect responses prior to any substantial experience with college life.

The Student Information Form

The Student Information Form is designed to serve two functions: first, to obtain student input data for longitudinal research; and second, to obtain standard descriptive and normative data for general information. Therefore, it contains a number of standard biographical and demographic items that have been administered annually to each entering class. It also contains research-oriented items that are either new (e.g., students were asked for the first time this year whether they felt that they would need special tutoring or remedial work, and if so, in which subjects) or modified from items used in previous years (e.g., expansion and rewording of racial/ethnic categories). The inclusion of both old and new items permits the most thorough coverage of a wide range of student characteristics but also represents a compromise between two dissimilar objectives: comparability of information from year to year and flexibility in item content to meet the changing needs in longitudinal research. Table 2 lists the items in the 1971 Student Information Form and indicates

Table 2
Use of 1971 Student Information Form Items in Earlier Surveys

1971 Item No.	1971 Item Description	1970	1969	1968	1967	1966
1.	Sex	X	X	X	X	X
2.	Marital status	X	-	-	-	-
3.	Age	X	X	X	X	X
4.	Average high school grade	X	X	X	X	X
5.	Rank in high school class ^a	X	X	X	-	-
6.	High school graduate of preceding year	X	-	-	-	-
7.	Veteran status	X	-	-	-	-
8.	Transfer status	X	X	X	X	-
9.	High school accomplishments	X	X	X	X	X
10.	Degree aspirations	X	X	X	X	X
11.	Distance of college from home ^a	X	X	-	-	-
12.	Parents' education	X	X	X	X	X
13.	Concern about finances	X	X	X	X	X
14.	Financial sources for education ^a	X	X	X	X	X
15.	Parental family income ^b	X	X	X	X	X
16.	Racial ethnic background ^c	X	X	X	X	X
17.	Religious background & current preference ^d	X	X	X	X	X
18.	Reasons for going to college	-	-	-	-	-
19.	High school activities ^a	X	X	X	X	X
20.	Political self-characterization ^e	X	X	-	-	-
21.	Student's career choice & parents' occupations ^f	X	X	X	X	X
22.	Self-ratings of traits	-	-	-	-	X
23.	Attitudes on public issues ^a	X	X	X	X	X
24.	Attitudes on academic issues ^a	X	X	X	X	X
25.	Chances that certain events will occur during college ^a	X	X	X	X	X
26.	Felt need for tutoring in specific subjects	-	-	-	-	-
27.	Choices of undergraduate major field ^a	X	X	X	X	X
28.	Values (life goals) ^a	X	X	X	X	X
29.	Reasons for choice of particular college	-	-	-	-	-

^aThese lists or categories have varied somewhat over the survey years.

^bIn 1967, this item included an additional response category: "I have no idea." Moreover, prior to 1970, fewer income categories were listed.

^cBeginning in 1969, "Caucasian" was changed to "White/Caucasian" and "Negro" was changed to "Black/Negro/Afro-American." In 1971, this item was changed to accommodate multiple responses; and two additional response categories were added: "Mexican-American/Chicano" and "Puerto Rican-American."

^dIn 1969 and 1970, detailed denominational affiliations were requested. In 1969, both father's and mother's religious preferences were requested.

^eBeginning in 1970, the response category "Left" was changed to "Far Left" and "Strongly Conservative" was changed to "Far Right".

^fFather's and mother's occupations not included in 1966. Students instead gave "second" and "least appealing" career choices.

their comparability with items used in previous surveys.⁶

A copy of the Student Information Form is reproduced in Appendix B. This form -- designed for self-administration under proctored conditions and for processing onto magnetic tape by means of an optical mark reader -- was developed in close collaboration with students, representatives of professional associations, of the participating institutions, and of governmental agencies, educational researchers and administrators.

Each year, four tape files are developed from the Student Information Form: (1) an institutional summary file containing institutional identification numbers and an institutional summary of the responses for men and women; (2) a file containing individual responses and a student identification number, but no names and addresses; (3) a name-and-address file containing a second independent student identification number but no other data; this file is used only in the mailing out of followup questionnaires required for longitudinal research; and (4) a "link" file containing only the two independent identification numbers. This last file is maintained under an elaborate system developed to assure strict confidentiality of data from individual students and to protect against misuse of the name-and-address file (Astin and Boruch, 1970).

⁶Several items (e.g., probable major field of study) have been recoded into a smaller number of categories in the data presented in this norms report. Because such coding schemes cannot satisfy all needs, the original questionnaire responses and the recoding scheme used to report the data are shown in Appendix C.

1971 National Norms

Table 3 shows the numbers of institutions and of students on which the 1971 national norms are based; it also gives an estimate -- derived through the weighting procedures -- of the total student population.⁷ The 326 institutions included in the national norms are divided into two-year colleges, four-year colleges, and universities. They are then further divided into nine other categories: two-year public colleges, two-year private colleges, technological institutions, four-year public colleges, four-year private nonsectarian colleges, four-year Protestant colleges, four-year Roman Catholic colleges, public universities, and private universities. The first category shown in Table 3 includes all institutions. In addition to these 13 categories, normative data are presented for 11 "supplementary" categories: four geographic regions,⁸ six sectarian categories further subdivided by sex and control, and predominantly black institutions. Appendix D indicates the relationship between the sampling design (stratification cell assignment) and the assignment of institutions to norms groups.

The items of normative data appear in the same order in the norms report and in the individual reports furnished to each

⁷These "head counts" of students entering different types of colleges are based in part on reports of total first-time, full-time students in 1971 given by each of our institutional representatives. These reports are then weighted in terms of the procedure described earlier.

⁸The assignment of a state to a given region is based on the same criteria used by the United States Office of Education.

participating institution.⁹ The first 24 pages of the national norms present item data separately for men, women, and all students according to the first 13 categories shown in Table 3; the following 16 pages show norms for the remaining four regional categories and the seven additional categories of institutions.

The different types of institutions can be compared on any given item by examining the percentages in the row following the item. For many items the data differ substantially among categories of institutions. It should be emphasized that there is also considerable variation within any category of institution.

Precision of the Normative Data and Their Comparisons

Although it is impractical to report statistical indicators of the precision of every reported categorical percentage in every norms group, some idea of the confidence that may be placed in the reported data is important in comparing data across the norms groups, across related item categories, and over time (i.e., with data from earlier norms reports). Because of major modifications in the stratification scheme, time trend analyses, based on comparisons of the 1971 normative data with earlier reports in the series, should be made with caution.¹⁰ Changes from earlier years

⁹A copy of an actual institutional report is shown in Appendix E.

¹⁰A data processing error has recently been discovered in the 1970 norms. The error was restricted to a single large two-year college with large minority enrollments which received a disproportionately high weight. Comparisons against that year are therefore particularly tenuous. Corrected 1970 norms, which are also based on the new stratification scheme, will be published in the future.

Table 3

Number of Institutions and Students Used in
Computing Weighted National Norms for 1971

Norm Group	Number of Institutions Used in Norms	Number of 1971 Entering Freshmen ^a		
		Actual Participants	Weighted Number ^b	Totals % Men
All institutions	326	171,509	1,634,154	54.4
All 2-year colleges	64	28,727	645,297	58.2
All 4-year colleges	230	91,313	613,268	50.0
All universities	32	51,469	375,595	54.9
2-year public colleges	39	23,134	583,453	59.3
2-year private colleges	25	6,593	61,844	47.6
Technological institutions	12	6,898	52,763	90.0
4-year public colleges ^c	33	25,686	306,783	44.6
4-year private nonsectarian ^c	70	24,383	101,886	49.1
4-year Protestant colleges ^c	69	20,803	98,277	48.7
4-year Catholic colleges ^c	46	13,543	53,572	46.1
Public universities	17	37,497	295,542	53.6
Private universities	15	13,972	80,054	60.0
Region of institution:				
East	123	60,663	573,180	57.9
Midwest	91	55,727	528,618	53.1
South	78	35,099	333,611	49.8
West	34	20,020	198,754	55.3
Nonsectarian colleges for men ^d	11	4,313	11,870	----
Nonsectarian colleges for women	11	3,705	12,091	----
Nonsectarian coed colleges	48	16,365	77,924	51.0
Catholic colleges for men	10	4,032	14,409	----
Catholic colleges for women	16	2,730	10,342	----
Catholic coed colleges	20	6,781	28,821	43.2
Predominantly Black colleges	20	7,636	42,348	46.8

^aFirst-time, full-time.

^bWeighted subtotals may not sum exactly to weighted totals due to rounding of the weights.

^cIncludes only liberal arts and teachers colleges.

^dThe definition of Nonsectarian Colleges for Men excludes all technological institutions. This is consistent with the definition employed previously except in 1967, when five technological institutions were included in the definition of Nonsectarian Colleges for Men.

which are an artifact of the revised stratification are particularly marked in regard to head counts within some norms groups, the effect being to now more closely approximate known institutional subpopulation counts. Nevertheless, it appears that the normative data are relatively unchanged by the modifications in the stratification design. The 1971 norms were also calculated on the basis of the stratification scheme employed in 1970, but comparisons of results for the larger aggregates of norms groups indicated no major discrepancies due to the application of the alternate schemes. However, norms for selected years since 1966 and including 1970 will be published by ACE in the future based on the stratification scheme introduced this year, in order that more directly comparable data for time trend analyses will be available.

While reported categorical percentages may be multiplied by the total number of students estimated for a norms group in order to convert the data into frequencies (to be used, for instance, in estimating facility requirements in program planning), both the reported percentages and the estimated number of students in a total group are subject to sampling errors. So far as random errors are concerned, the standard error of a categorical percentage for the total normative sample is about 0.1 percent; it is somewhat larger in the norms groups based on various subpopulations of the domain. For the smallest norms groups, the standard error may be as large as 2 percent. Because the sampling design introduces no explicit control for regional differences among institutions, somewhat less confidence can be placed in the regional norms.

The chief source of error in stratified sampling is the nonrepresentativeness of samples within each stratification cell. Although reasonable precautions are taken to minimize known sources of systematic bias, the reported data are subject to some unknown degree of constant and nonrandom variable errors. The actual magnitude of such errors is probably too small to have any adverse effect on decision making in higher education. Caution is necessary, however, when a participating institution compares its own summary data with the data for the corresponding national norm group, especially when the institution is very small or when it has not surveyed all of its entering freshmen.

In spite of these potential hazards, communications from users indicate that the national norms published in this series are highly useful, and are sufficiently accurate to be used with confidence both in research and in matters of practical concern to higher education. Additional analyses of freshmen and followup data collected through the Cooperative Institutional Research Program will be performed by the American Council on Education, at cost, for any individual or organization requesting such analyses through the ACE data-accessing system (Bayer et al., 1969).

References

- The American Council on Education's Office of Research: Its Purposes and Activities. MS, Washington, 1971.
- Astin, Alexander W., and Boruch, Robert F. A "Link" System for Assuring Confidentiality of Research Data in Longitudinal Studies. ACE Research Reports, Vol. 5, No. 3. Washington: ACE, 1970.
- Astin, Alexander W., Panos, Robert J., and Creager, John A. A Program of Longitudinal Research on the Higher Educational System. ACE Research Reports, Vol. 1, No. 1. Washington: ACE, 1966.
- Bayer, Alan E., Astin, Alexander W., Boruch, Robert F., and Creager, John A. Users' Manual: ACE Higher Education Data Bank. ACE Research Reports, Vol. 4, No. 1. Washington: ACE, 1969.
- Bayer, Alan E., Drew, David E., Astin, Alexander W., Boruch, Robert F., and Creager, John A. The First Year of College: A Follow-Up Normative Report. ACE Research Reports, Vol. 5, No. 1. Washington, ACE, 1970.
- Creager, John A. General Purpose Sampling in the Domain of Higher Education. ACE Research Reports, Vol. 3, No. 2. Washington: ACE, 1968.
- Creager, John A., Astin, Alexander W., Boruch, Robert F., and Bayer, Alan E. National Norms for Entering College Freshmen--Fall 1968. ACE Research Reports, Vol. 3, No. 1. Washington, ACE, 1968.
- Creager, John A., and Boruch, Robert F. The Cooperative Institutional Research Program of the American Council on Education. Washington: ACE, 1971.

Federation of Regional Accrediting Commissions on Higher Education.

Accredited Institutions of Higher Education, 1970-71.

Washington: ACE, 1970.

U.S. Office of Education. Education Directory: Higher Education

1969-70. Washington, U.S. Government Printing Office, 1970.

1971 National Norms

AMERICAN COUNCIL ON EDUCATION
OFFICE OF RESEARCH FALL 1971
WEIGHTED NATIONAL NORMS FOR FRESHMAN MEN

	All Insti- tutions	All 2-Year Colleges	All 4-Year Colleges	All Uni- versities	2-Year Colleges		4-Year Colleges				Universities		
					Public	Private	Technical Institutions	Public	Private Nonsect.	Prot- estant	Catholic	Public	Private
AGE BY DECEMBER 31, 1971													
16 OR YOUNGER	.1	.0	.1	.1	.0	.0	.1	.0	.2	.1	.1	.0	.2
17	2.6	1.5	3.0	4.0	1.4	2.7	3.4	2.0	5.0	3.1	3.0	2.9	7.4
18	70.5	61.5	75.3	79.5	61.4	62.8	78.7	74.2	75.4	72.6	79.8	79.3	80.2
19	18.6	23.2	16.4	13.5	23.2	23.0	15.0	16.7	15.6	18.9	13.9	14.3	10.9
20	2.6	4.3	1.7	.8	4.3	4.2	1.6	1.7	1.6	2.3	1.4	1.0	.4
21	.9	1.5	.6	.4	1.5	1.5	.4	.7	.4	.7	.4	.5	.2
22-25	3.6	6.0	2.2	1.3	6.1	4.5	.6	3.4	1.3	1.4	1.2	1.6	.4
26 OR OLDER	1.2	2.0	.8	.4	2.0	1.3	.2	1.2	.5	.9	.3	.4	.2
FATHER'S EDUCATION													
GRAMMAR SCHOOL OR LESS	8.8	10.8	8.3	5.7	10.8	11.1	5.7	11.1	5.2	7.2	6.2	6.2	3.9
SOME HIGH SCHOOL	16.7	21.3	14.9	10.8	21.6	18.3	13.3	18.2	11.2	12.1	13.2	11.7	7.9
HIGH SCHOOL GRADUATE	31.9	36.0	30.2	27.0	36.4	31.1	29.9	34.8	23.2	24.9	29.9	28.9	20.8
SOME COLLEGE	16.4	15.3	16.6	18.2	15.1	17.3	19.6	15.6	15.6	16.7	17.7	18.6	17.1
COLLEGE DEGREE	17.6	12.6	19.1	24.2	12.4	15.6	21.2	14.4	25.1	22.9	21.7	23.3	27.3
POSTGRADUATE DEGREE	8.7	3.9	10.8	14.0	3.7	6.6	10.2	5.9	19.6	16.3	11.3	11.3	22.9
MOTHER'S EDUCATION													
GRAMMAR SCHOOL OR LESS	5.3	6.8	4.7	3.4	6.8	6.5	4.3	5.6	3.4	4.1	4.5	3.7	2.7
SOME HIGH SCHOOL	13.6	17.1	12.7	8.8	17.2	15.7	11.9	15.6	9.6	9.8	10.8	9.5	6.5
HIGH SCHOOL GRADUATE	47.0	50.8	45.3	42.8	51.2	45.5	47.1	49.0	37.1	39.1	49.9	45.0	35.5
SOME COLLEGE	16.8	14.1	17.3	20.9	13.9	16.9	18.4	15.7	19.2	19.7	15.8	20.5	22.2
COLLEGE DEGREE	14.4	9.9	16.2	20.0	9.6	13.4	15.5	11.8	23.6	22.1	16.1	18.3	25.7
POSTGRADUATE DEGREE	2.8	1.4	3.7	4.0	1.4	2.0	2.9	2.3	7.2	5.2	3.0	3.0	7.3
RACIAL BACKGROUND (1)													
WHITE/CAUCASIAN	92.1	92.4	89.5	95.5	92.2	94.7	93.2	88.8	87.6	87.6	94.5	96.1	93.8
BLACK/NEGRO/AFRO-AMERICAN	5.5	4.2	8.8	2.8	4.3	2.9	4.5	10.0	10.4	10.8	2.8	2.6	3.5
AMERICAN INDIAN	1.0	1.1	.9	.9	1.1	1.0	.5	.8	1.0	1.1	.6	1.0	.6
ORIENTAL	.5	.3	.5	.9	.3	.4	1.2	.2	.7	.5	.5	.6	1.7
MEXICAN-AMERICAN/CHICANO	1.1	2.0	.3	.4	2.2	.4	.5	.1	.2	.4	1.3	.3	.6
PUERTO RICAN-AMERICAN	.2	.1	.4	.2	.1	.1	.1	.5	.3	.2	.5	.1	.4
OTHER	1.2	1.3	1.0	1.0	1.3	2.2	1.3	.7	1.4	1.2	1.4	1.0	.9
ESTIMATED PARENTAL INCOME													
LESS THAN \$4,000	4.9	6.3	4.6	2.7	6.2	7.1	1.7	5.9	4.2	5.4	2.9	2.9	2.0
\$4,000 - \$5,999	6.4	7.6	6.5	4.1	7.6	6.9	3.8	8.5	4.8	6.5	4.6	4.3	3.3
\$6,000 - \$7,999	9.8	12.1	8.9	6.8	12.2	11.4	6.9	11.1	6.7	8.3	6.6	7.5	4.7
\$8,000 - \$9,999	12.9	15.1	11.6	11.0	15.2	13.8	11.8	13.2	8.5	10.3	11.3	12.0	7.9
\$10,000 - \$12,499	18.5	20.0	17.4	17.2	20.3	17.1	19.5	18.7	13.8	15.5	17.4	18.3	13.4
\$12,500 - \$14,999	14.6	14.3	14.6	14.9	14.3	13.7	18.3	14.6	12.2	13.2	15.5	15.9	11.9
\$15,000 - \$19,999	14.6	12.6	15.3	17.2	12.6	13.2	19.5	13.8	15.0	14.7	16.5	17.3	16.8
\$20,000 - \$24,999	7.9	5.9	8.5	10.7	5.8	6.1	9.9	6.7	10.6	9.2	9.7	10.1	12.6
\$25,000 - \$29,999	3.7	2.5	4.1	5.3	2.4	3.7	4.3	2.9	6.6	4.5	4.6	4.7	7.3
\$30,000 - \$34,999	2.2	1.4	2.6	3.0	1.4	2.5	1.6	1.7	4.8	3.6	3.5	2.5	4.9
\$35,000 - \$39,999	1.2	.6	1.5	1.7	.5	1.2	1.1	.8	3.1	2.0	1.9	1.2	3.3
\$40,000 OR MORE	3.4	1.6	4.3	5.5	1.5	3.2	1.7	2.1	9.8	6.7	5.5	3.5	12.0

AMERICAN COUNCIL ON EDUCATION
OFFICE OF RESEARCH FALL 1971
WEIGHTED NATIONAL NORMS FOR FRESHMAN MEN

	All Insti- tutions	All 2-Year Colleges	All 4-Year Colleges	All Uni- versities	2-Year Colleges		4-Year Colleges					Universities	
					Public	Private	Technical Institutions	Public	Private Nonsect.	Prot- estant	Catholic	Public	Private
RELIGION REARED													
PROTESTANT	47.8	44.1	50.5	50.6	43.5	50.9	49.8	52.8	47.8	70.3	7.3	53.6	40.9
ROMAN CATHOLIC	36.2	39.5	34.5	32.8	41.0	22.2	42.0	31.1	28.0	14.4	89.5	82.2	35.0
JEWISH	3.6	1.8	3.3	7.2	1.9	1.1	1.6	1.9	11.3	1.8	.5	4.5	16.3
OTHER	9.8	11.8	9.4	6.7	10.8	23.1	4.3	11.9	9.7	11.3	1.8	7.2	5.0
NONE	2.6	2.8	2.3	2.6	2.8	2.7	2.3	2.3	3.2	2.3	.9	2.6	2.7
RELIGIOUS PREFERENCE													
PROTESTANT	38.7	35.8	42.0	39.1	35.1	44.8	44.8	44.1	34.6	59.9	5.4	42.3	28.8
ROMAN CATHOLIC	30.1	34.0	28.6	25.4	35.2	20.1	37.1	25.7	20.6	11.2	77.3	24.8	27.5
JEWISH	2.8	1.4	2.4	5.7	1.5	1.0	1.4	1.4	8.2	1.3	.5	3.5	13.1
OTHER	12.0	13.9	11.7	9.2	13.0	24.8	5.5	13.9	13.4	13.8	4.7	9.8	7.5
NONE	16.3	14.8	15.3	20.4	15.3	9.4	11.2	15.0	23.2	13.8	12.1	19.6	23.2
FATHER'S OCCUPATION (2)													
ARTIST (INCL PERFORMER)	.8	.7	.7	.9	.7	.6	.7	.5	1.2	.9	.7	.8	1.3
BUSINESSMAN	29.7	26.7	30.9	33.4	26.3	31.1	28.7	26.9	38.1	33.2	38.6	31.3	40.3
CLERGYMAN	.8	.6	1.3	.6	.4	2.8	.4	.8	1.5	4.1	.1	.5	.8
COLLEGE TEACHER	.7	.3	.8	1.1	.3	.4	.7	.5	1.3	1.5	.5	1.0	1.7
DOCTOR (M.D. OR D.D.S.)	1.8	.7	2.2	3.2	.6	1.3	.8	1.1	4.7	3.8	3.2	2.1	6.5
EDUCATOR (SECONDARY)	2.1	1.6	2.7	2.3	1.6	1.1	3.0	2.7	2.6	2.9	2.0	2.3	2.1
ELEMENTARY TEACHER	.3	.3	.4	.3	.2	.6	.5	.4	.4	.5	.3	.3	.3
ENGINEER	7.5	6.6	6.9	10.0	6.6	6.4	9.9	6.0	7.1	6.3	6.5	10.1	9.7
FARMER OR FORESTER	6.7	8.3	5.1	6.3	8.5	5.2	2.2	7.8	2.2	5.0	1.8	7.8	1.4
HEALTH PROFESSIONAL (NON-M.D.)	1.2	1.1	1.1	1.5	1.1	1.1	1.2	1.0	1.5	1.1	1.1	1.5	1.6
LAWYER	1.1	.5	1.4	1.9	.5	.7	1.0	.6	3.0	1.7	2.4	1.4	3.7
MILITARY CAREER	2.1	1.4	3.0	1.9	1.3	1.9	8.5	2.7	1.0	1.6	1.1	2.0	1.4
RESEARCH SCIENTIST	.5	.2	.5	1.1	.2	.3	.5	.3	1.0	.7	.6	1.0	1.6
SKILLED WORKER	13.5	16.3	12.3	10.5	16.5	13.6	13.9	13.6	9.2	10.2	11.5	11.3	7.8
SEMI-SKILLED WORKER	8.4	10.1	8.0	6.0	10.2	8.6	6.8	10.0	6.0	6.3	7.0	6.4	4.7
UNSKILLED WORKER	3.8	4.6	3.8	2.5	4.7	3.3	3.3	4.8	2.6	3.2	3.3	2.7	1.7
UNEMPLOYED	1.2	1.4	1.1	.8	1.4	1.8	.8	1.4	1.0	1.0	.8	.8	.7
OTHER	17.6	18.7	17.6	15.7	18.7	19.3	17.1	18.9	15.6	16.1	18.3	16.6	12.6
VETERAN													
NO	95.0	91.9	96.7	98.2	91.6	94.9	96.7	95.1	98.3	98.2	98.7	97.8	99.5
YES, SERVED IN SOUTHEAST ASIA	2.7	4.5	1.6	.9	4.6	2.7	.3	2.7	.8	.9	.9	1.2	.2
YES, DID NOT SERVE IN SE ASIA	2.3	3.6	1.8	.9	3.7	2.4	3.0	2.2	.8	.9	.4	1.0	.3
MARITAL STATUS													
PRESENTLY MARRIED	3.0	4.6	2.2	1.3	4.7	3.5	.6	3.2	1.3	2.0	1.3	1.5	.6
NOT MARRIED	97.0	95.4	97.8	98.7	95.3	96.5	99.4	96.8	98.7	98.0	98.7	98.5	99.4
DISTANCE FROM HOME TO COLLEGE													
5 MILES OR LESS	11.2	17.4	7.0	6.2	18.0	10.4	3.4	8.0	6.4	6.5	10.3	6.5	5.3
6-10 MILES	12.3	18.3	6.9	9.6	19.2	7.7	6.0	7.1	7.5	3.4	13.0	9.9	8.3
11-50 MILES	26.7	36.0	20.8	18.6	36.6	28.9	16.0	27.1	14.7	12.8	22.6	18.9	17.8
51-100 MILES	14.1	12.4	15.0	15.6	12.1	16.0	8.7	17.7	12.0	17.2	13.7	18.0	7.9
101-500 MILES	27.1	13.6	33.9	41.5	12.5	26.9	23.3	34.7	39.5	38.8	28.8	42.2	39.1
MORE THAN 500 MILES	8.6	2.1	16.5	8.5	1.4	10.2	42.6	5.4	20.0	21.3	11.5	4.6	21.6

**AMERICAN COUNCIL ON EDUCATION
OFFICE OF RESEARCH FALL 1971
WEIGHTED NATIONAL NORMS FOR FRESHMAN MEN**

	All Insti- tutions	All 2-Year Colleges	All 4-Year Colleges	All Uni- versities	2-Year Colleges		4-Year Colleges					Universities	
					Public	Private	Technical Institutions	Public	Private Nonsect.	Prot- estant	Catholic	Public	Private
AVERAGE GRADE IN HIGH SCHOOL													
A OR A+	4.3	1.0	4.8	9.6	.9	1.6	13.2	1.3	7.1	4.5	4.1	6.1	21.1
A-	7.0	2.4	8.4	13.1	2.4	3.2	19.7	3.9	10.8	8.1	6.6	11.0	19.9
B+	13.8	7.7	16.7	20.5	7.7	7.0	27.1	12.2	18.5	16.3	17.8	20.1	22.0
B	22.4	20.1	24.2	23.9	20.5	15.5	23.4	24.0	24.9	22.9	27.8	25.5	18.5
B-	18.5	20.1	17.9	16.5	20.5	16.0	10.1	20.7	16.2	19.0	19.0	18.4	10.3
C+	19.3	26.4	16.4	11.0	26.3	27.3	4.6	21.7	13.2	17.1	15.1	12.5	6.1
C	13.7	20.6	11.1	5.2	20.1	27.2	1.8	15.4	8.6	11.3	9.0	6.1	2.0
D	.9	1.6	.6	.2	1.6	2.1	.0	.7	.6	.7	.5	.2	.1
RANK IN HIGH SCHOOL CLASS													
TOP QUARTER	35.1	15.5	42.6	59.1	15.4	16.9	74.9	30.8	47.7	42.4	35.2	54.9	72.7
SECOND QUARTER	32.0	32.2	33.8	28.9	32.4	29.8	19.5	40.1	30.2	33.4	35.3	31.8	19.6
THIRD QUARTER	27.5	43.2	20.3	10.4	43.1	44.5	4.8	25.6	18.2	20.3	24.7	11.5	6.9
FOURTH QUARTER	5.3	9.1	3.3	1.6	9.2	8.8	.8	3.5	3.8	3.9	4.7	1.8	.9
SECONDARY SCHOOL ACHIEVEMENTS													
PRESIDENT STUDENT ORGANIZATION	18.4	12.4	22.5	23.2	12.1	16.0	29.1	18.7	24.2	26.8	19.6	21.8	27.9
HIGH RATING STATE MUSIC CONTEST	8.4	6.5	9.5	10.3	6.3	8.0	7.9	9.9	8.3	13.7	4.8	10.6	9.4
STATE/REGIONAL SPEECH CONTEST	4.2	2.7	4.9	5.8	2.5	4.0	5.7	4.3	5.6	5.1	5.4	5.3	7.6
MAJOR PART IN A PLAY	14.4	11.6	16.6	16.2	11.4	14.0	14.0	16.1	17.4	20.4	15.1	16.3	15.9
VARSITY LETTER (SPORTS)	46.9	43.0	52.7	45.4	42.8	44.8	59.2	51.3	50.9	54.5	48.2	45.6	44.6
AWARD IN ART COMPETITION	4.8	5.2	4.6	4.5	5.2	5.5	3.5	4.5	5.5	5.2	3.9	4.7	3.8
EDITOR OF SCHOOL PAPER	8.2	5.7	9.7	10.4	5.6	6.8	9.2	7.9	13.1	10.8	11.5	9.0	15.2
ORIGINAL WRITING PUBLISHED	12.5	8.4	14.8	16.6	8.3	10.0	13.6	12.0	20.1	17.7	16.0	14.8	22.6
NSF SUMMER PROGRAM	.9	.3	.9	1.7	.3	.3	1.8	.6	1.3	.7	.6	1.0	3.9
STATE/REGIONAL SCIENCE PROGRAM	2.2	1.4	2.3	3.4	1.4	1.8	3.2	2.0	2.4	2.4	1.7	2.9	4.8
SCHOLASTIC HONOR SOCIETY	18.6	6.5	23.4	33.8	6.3	8.5	49.3	13.6	27.0	23.2	20.3	29.4	48.0
NATIONAL MERIT RECOGNITION	7.5	2.8	8.9	13.9	2.9	2.2	14.5	4.7	16.3	8.0	7.7	9.6	28.1
YEAR FINISH SECONDARY SCHOOL **													
GRADUATED IN 1971	88.6	82.3	91.9	94.9	82.1	85.3	92.4	90.2	93.9	92.7	94.9	94.3	97.0
DID NOT GRADUATE IN 1971	11.4	17.7	8.1	5.1	17.9	14.7	7.6	9.8	6.1	7.3	5.1	5.7	3.0
HIGHEST DEGREE PLANNED													
NONE	6.5	10.4	4.1	3.1	10.7	7.1	2.9	4.4	3.9	4.3	4.2	3.3	2.5
ASSOCIATE (OR EQUIVALENT)	8.3	18.4	1.1	.8	19.3	7.4	.1	2.0	.4	.8	.5	1.0	.1
BACHELOR'S (B.A., B.S.)	33.8	34.7	34.2	31.6	34.4	38.3	25.4	41.1	28.7	30.5	31.3	35.9	17.3
MASTER'S (M.A., M.S.)	25.4	19.1	31.0	28.3	18.6	25.0	43.6	30.2	26.2	27.0	28.4	29.2	25.3
PH.D. OR ED.D.	9.7	4.7	12.7	14.1	4.4	7.4	20.3	9.0	15.6	13.3	11.4	11.8	21.7
M.D., D.O., D.D.S., OR D.V.M.	6.9	3.7	7.0	12.4	3.5	5.2	3.7	4.9	11.3	10.1	10.7	10.2	19.5
LL.B. OR J.D. (LAW)	5.6	2.8	7.1	8.2	2.7	3.9	3.3	5.7	10.8	9.0	11.0	7.0	12.2
B.D. (DIVINITY)	.5	.3	.8	.2	.2	1.4	.2	.3	1.0	2.7	.6	.2	.2
OTHER	3.5	6.0	2.0	1.3	6.1	4.4	.4	2.3	2.0	2.4	1.9	1.4	1.1
CONCERN ABOUT FINANCING COLLEGE													
NO CONCERN	35.3	37.0	35.7	31.5	37.0	36.4	64.6	29.4	34.8	31.4	27.3	30.4	35.3
SOME CONCERN	55.0	54.0	53.8	58.5	54.1	53.2	31.8	58.7	54.2	56.3	60.9	59.1	56.4
MAJOR CONCERN	9.7	9.0	10.5	10.0	8.9	10.4	3.6	11.8	11.0	12.3	11.8	10.5	8.4

**AMERICAN COUNCIL ON EDUCATION
OFFICE OF RESEARCH FALL 1971
WEIGHTED NATIONAL NORMS FOR FRESHMAN MEN**

	All Insti- tutions	All 2-Year Colleges	All 4-Year Colleges	All Uni- versities	2-Year Colleges		4-Year Colleges					Universities	
					Public	Private	Technical Institutions	Public	Private Nonsect.	Prot- estant	Catholic	Public	Private
MAJOR SOURCES OF FINANCIAL SUPPORT FOR COLLEGE (1)													
PART-TIME OR SUMMER WORK	34.2	39.6	28.5	33.0	40.8	26.0	16.7	34.2	23.8	26.3	33.5	36.2	22.4
SAVINGS FROM FULL-TIME EMPLOY	11.5	14.4	10.1	8.4	14.8	8.9	17.6	10.2	6.7	7.1	8.2	9.4	5.3
PARENTAL OR FAMILY AID OR GIFTS	48.9	39.8	50.9	62.5	38.7	53.4	21.3	49.8	67.5	62.8	57.1	59.9	70.9
PARENT'S MILITARY SERVICE	1.9	2.3	1.8	1.5	2.3	2.0	1.1	2.2	1.6	1.5	1.6	1.7	1.0
PERSONAL MILITARY SERVICE	4.5	6.9	3.4	1.7	7.2	4.4	6.1	4.2	1.4	1.6	1.1	2.0	.5
SCHOLARSHIPS AND GRANTS	18.4	12.3	23.8	21.4	11.6	21.1	27.1	18.9	26.1	31.1	26.1	17.0	36.1
LOANS-NDEA/GOV'T INSURED/COLLEGE	13.8	11.7	15.9	14.3	11.2	17.7	4.1	14.0	20.4	24.2	24.4	12.3	21.1
OTHER REPAYABLE LOANS	5.6	5.5	6.6	4.3	5.4	7.2	3.6	6.1	8.1	8.3	8.9	4.1	5.2
PROBABLE MAJOR FIELD OF STUDY(2)													
AGRICULTURE (INCL FORESTRY)	5.4	8.0	2.4	5.1	8.4	3.7	.4	3.7	2.7	1.5	.6	6.6	.1
BIOLOGICAL SCIENCES	4.4	3.1	5.3	5.4	3.1	2.8	4.5	5.3	5.7	5.7	5.0	5.5	5.2
BUSINESS	18.3	23.4	16.7	11.8	23.7	18.7	9.0	19.4	14.7	15.6	22.8	12.4	9.9
EDUCATION	4.6	4.9	6.1	2.1	4.6	7.6	.5	9.5	3.6	6.0	3.5	2.4	1.3
ENGINEERING	13.2	14.3	10.7	15.1	14.3	14.1	40.8	5.8	4.3	3.9	4.4	14.9	16.0
ENGLISH	1.1	.7	1.6	1.3	.7	.7	.7	1.3	2.5	1.5	2.9	1.2	1.8
HEALTH PROFESSIONS (NON-M.D.)	2.6	3.0	2.3	2.3	3.0	3.0	.6	2.6	4.0	1.7	2.0	2.5	1.7
HISTORY, POLITICAL SCIENCE	5.2	2.9	7.8	5.3	2.8	4.6	6.1	7.5	9.0	8.0	10.1	4.6	7.5
HUMANITIES (OTHER)	2.1	1.5	3.2	1.6	1.3	3.8	1.5	1.7	4.6	7.8	3.4	1.4	2.3
FINE ARTS	8.4	9.2	7.2	8.7	8.9	13.1	2.2	8.5	8.0	9.1	4.5	9.6	5.6
MATHEMATICS OR STATISTICS	2.6	1.3	3.4	3.6	1.3	1.2	4.3	3.4	2.9	3.3	3.4	3.3	4.5
PHYSICAL SCIENCES	3.1	1.4	3.8	5.0	1.4	1.0	7.1	2.9	3.5	3.5	2.8	4.5	6.6
PRE-PROFESSIONAL	12.4	7.7	13.5	19.1	7.5	10.8	6.1	11.3	18.6	18.3	20.0	16.7	26.9
SOCIAL SCIENCES	5.6	4.2	7.1	5.7	4.2	4.2	2.3	6.9	9.3	8.7	9.7	5.6	6.0
OTHER FIELDS (TECHNICAL)	7.3	10.6	4.7	5.1	11.1	5.7	4.0	6.4	3.8	2.6	3.1	5.9	2.7
OTHER FIELDS (NONTECHNICAL)	1.4	1.5	2.0	.5	1.4	1.9	9.0	.9	.5	.5	.4	.6	.3
UNDECIDED	2.3	2.4	2.3	2.2	2.4	2.8	1.1	2.8	2.4	2.2	1.5	2.4	1.6
PROBABLE CAREER OCCUPATION (2)													
ARTIST (INCL PERFORMER)	4.9	4.7	5.3	4.8	4.5	6.6	1.0	6.0	7.1	6.2	4.3	5.0	4.0
BUSINESSMAN	16.1	20.2	14.8	11.1	20.5	16.6	8.2	16.6	13.9	14.2	21.0	11.6	9.7
CLERGYMAN	1.0	.7	1.9	.5	.3	4.8	.3	.6	2.3	6.2	3.0	.3	.9
COLLEGE TEACHER	.8	.4	1.1	.9	.4	1.1	.6	1.0	1.5	1.5	.8	.7	1.8
DOCTOR (M.D. OR D.D.S.)	6.4	2.8	7.0	11.9	2.6	5.0	2.9	4.9	11.1	10.5	11.7	9.1	21.1
EDUCATOR (SECONDARY)	6.6	5.5	9.7	4.1	5.4	7.5	1.7	14.6	5.7	8.8	8.0	4.5	2.8
ELEMENTARY TEACHER	.9	.8	1.3	.3	.7	1.5	.0	2.0	.8	1.1	1.3	.3	.2
ENGINEER	9.7	8.8	8.0	13.5	8.7	10.1	29.9	4.0	3.6	3.4	3.9	13.4	13.9
FARMER OR FORESTER	4.8	6.7	2.7	4.5	7.0	3.4	.7	4.0	2.8	2.1	1.0	5.8	.4
HEALTH PROFESSIONAL (NON-M.D.)	3.8	4.2	3.1	4.2	4.2	4.2	1.0	3.5	4.7	2.9	2.2	5.0	1.8
LAWYER	6.8	3.6	8.5	9.7	3.5	4.8	3.2	7.2	12.5	11.0	13.2	8.6	13.4
NURSE	.3	.6	.1	.1	.6	.0	.0	.2	.1	.1	.2	.2	.1
RESEARCH SCIENTIST	3.3	1.8	3.5	5.7	1.7	2.1	4.8	2.9	4.2	3.3	3.3	5.2	7.7
OTHER	21.7	27.4	19.2	15.7	28.0	20.0	38.4	17.7	12.6	13.0	13.6	17.3	10.6
UNDECIDED	12.9	12.0	13.9	12.8	12.0	12.2	7.4	14.9	17.1	15.5	12.4	13.2	11.7

**AMERICAN COUNCIL ON EDUCATION
OFFICE OF RESEARCH FALL 1971
WEIGHTED NATIONAL NORMS FOR FRESHMAN MEN**

	All Institutions	All 2-Year Colleges	All 4-Year Colleges	All Universities	2-Year Colleges		4-Year Colleges					Universities	
					Public	Private	Technical Institutions	Public	Private Nonsect.	Prot-estant	Catholic	Public	Private
REASONS NOTED AS VERY IMPORTANT IN DECIDING TO GO TO COLLEGE **													
PARENTS WANTED ME TO GO	21.9	22.0	22.9	20.1	21.4	30.0	21.1	22.2	23.6	26.0	22.5	20.2	20.1
CONTRIBUTE MORE TO MY COMMUNITY	15.0	12.9	17.1	15.4	12.5	18.5	17.8	14.4	19.8	20.2	19.4	13.9	20.4
GET A BETTER JOB	77.0	81.6	74.2	72.8	81.8	80.1	75.1	79.5	65.8	68.6	70.6	74.6	66.9
GAIN A GENERAL EDUCATION	53.3	49.4	56.5	55.5	49.1	52.7	58.1	53.4	62.7	56.7	56.9	52.8	64.2
IMPROVE READING/STUDY SKILLS	21.7	23.9	22.2	17.1	23.4	29.1	17.5	24.0	21.9	22.9	21.3	17.5	15.8
NOTHING BETTER TO DO	2.2	2.1	2.0	2.5	2.2	1.5	1.5	2.1	2.3	2.3	1.7	2.4	2.7
BECOME MORE CULTURED	24.5	24.2	26.4	22.3	23.8	28.9	25.0	26.1	26.6	28.2	27.1	21.5	25.1
MAKE MORE MONEY	57.0	63.4	52.8	51.8	63.6	61.3	49.2	59.5	44.8	47.8	48.4	54.4	43.1
LEARN MORE ABOUT MY INTERESTS	64.5	63.1	64.4	67.1	63.2	61.1	66.2	62.1	70.4	65.2	60.3	65.6	72.2
MEET NEW/INTERESTING PEOPLE	36.3	32.7	39.0	38.9	32.5	34.7	32.0	38.9	42.8	40.7	42.8	37.6	43.2
PREPARE FOR GRAD OR PROF SCHOOL	38.9	36.4	39.4	42.5	35.7	45.1	38.2	34.3	44.5	46.4	45.8	38.4	56.1
REASONS NOTED AS VERY IMPORTANT IN SELECTING THIS COLLEGE **													
RELATIVES WANTED ME TO GO	6.3	6.5	6.6	5.3	6.2	10.1	9.1	5.8	5.6	7.5	5.7	5.3	5.0
COLLEGE HAS A GOOD REPUTATION	34.7	26.7	38.8	43.3	24.9	47.8	64.2	26.0	44.7	43.3	39.3	38.3	59.3
MOST FRIENDS GOING TO THIS COL	4.6	6.1	3.3	3.7	6.2	5.6	.7	5.6	1.5	2.0	1.7	4.5	.9
LOW TUITION	18.9	26.0	12.6	15.1	27.8	4.6	20.9	17.2	4.7	3.0	5.2	19.2	1.9
ADVICE OF SOMEONE WHO ATTENDED	15.3	15.7	16.1	13.4	15.0	23.5	12.4	15.7	15.8	19.4	19.3	13.7	12.4
SPECIAL EDUC PROGRAM OFFERED	29.7	28.6	30.1	31.2	28.8	26.7	57.9	20.5	33.5	28.1	25.2	28.6	39.8
NOT ACCEPTED ANYWHERE ELSE	3.6	4.4	3.4	2.4	4.3	5.0	1.3	3.6	4.3	3.9	3.6	2.4	2.2
ADVICE OF GUIDANCE COUNSELOR	7.7	9.9	7.0	4.6	9.7	12.2	5.2	6.2	8.7	7.6	9.5	4.1	6.4
WANTED TO LIVE AT HOME	12.2	19.3	7.2	6.9	20.0	9.8	4.6	9.6	5.5	3.9	8.9	7.9	3.6
NEED FOR SPECIAL HELP IN (1) **													
ENGLISH	21.0	23.2	20.4	17.9	23.1	24.6	19.0	22.8	17.3	20.2	16.1	19.5	12.7
READING	12.5	12.9	11.9	12.7	12.9	13.0	12.6	11.1	12.1	13.3	11.7	13.6	9.8
MATHEMATICS	33.9	37.7	34.5	26.0	37.0	46.6	23.9	39.0	31.4	34.4	37.0	27.8	20.4
SOCIAL STUDIES	3.4	4.0	3.2	2.5	4.1	3.4	3.8	3.3	2.7	3.3	2.4	2.5	2.5
SCIENCE	16.1	15.7	18.3	13.8	15.3	20.2	17.7	17.9	17.5	19.4	21.0	14.3	12.2
FOREIGN LANGUAGE	24.2	19.8	29.9	23.8	18.9	30.9	28.1	27.9	29.2	36.5	32.6	24.6	21.2
AGREE STRONGLY OR SOMEWHAT													
GOV'T NOT CONTROLLING POLLUTION	90.3	89.1	90.8	91.9	89.1	88.5	90.2	90.5	92.4	90.7	91.0	91.4	93.4
GOV'T NOT PROTECTING CONSUMER	76.2	75.3	75.8	78.4	75.2	76.4	68.5	76.0	80.6	76.6	77.2	77.6	81.0
GOV'T NOT DESEGREGATING QUICKLY	50.6	51.5	49.9	50.1	52.1	44.6	40.3	50.6	57.6	48.1	52.9	48.7	54.5
TOO MANY RIGHTS FOR CRIMINALS	53.9	56.5	52.7	50.8	56.5	56.4	59.2	54.1	45.2	52.3	48.9	53.2	43.0
SHOULD ABOLISH DEATH PENALTY	53.2	49.8	54.8	57.0	49.8	50.5	47.3	53.9	61.4	54.4	62.0	54.8	64.1
WOMEN'S ACTIVITIES BEST IN HOME	51.9	57.5	51.0	43.2	56.9	64.3	49.5	53.8	43.7	51.3	52.6	45.5	35.8
BARELY COMMUNICATE WITH PARENTS	20.5	22.3	19.0	19.4	22.5	20.1	13.2	22.0	17.7	17.9	18.8	19.8	18.2
SHOULD LEGALIZE MARIJUANA	41.7	39.0	41.1	47.6	39.6	31.2	32.0	40.6	50.8	40.0	44.2	46.4	51.6
SHOULD DISCOURAGE LARGE FAMILIES	69.3	64.9	69.6	76.9	64.9	65.5	70.5	69.6	73.8	71.8	55.3	76.5	78.3
WOMEN SHOULD GET JOB EQUALITY	82.7	79.8	83.3	86.9	79.9	78.6	86.0	81.2	86.8	83.2	82.8	85.9	90.2
ALL SHOULD GET COL OPPORTUNITY	66.6	76.3	61.3	56.6	76.5	73.4	43.7	67.6	61.2	59.9	63.4	58.3	50.8
CAN DO LITTLE TO CHANGE SOCIETY	46.4	48.2	44.6	45.9	48.7	43.4	41.0	45.8	46.1	43.8	43.8	46.7	43.2

**AMERICAN COUNCIL ON EDUCATION
OFFICE OF RESEARCH FALL 1971
WEIGHTED NATIONAL NORMS FOR FRESHMAN MEN**

	All Institutions	All 2-Year Colleges	All 4-Year Colleges	All Universities	2-Year Colleges		4-Year Colleges					Universities	
					Public	Private	Technical Institutions	Public	Private Nonsect.	Prot-estant	Catholic	Public	Private
AGREE STRONGLY OR SOMEWHAT													
COL REGULATE STUDENTS OFF CAMPUS	14.1	15.4	14.9	10.8	14.7	22.8	14.4	14.7	12.4	19.5	12.9	40.8	10.9
BENEFIT OF COLLEGE IS MONETARY	66.2	74.2	61.8	58.0	74.3	71.9	60.5	68.4	53.0	56.1	57.0	61.7	45.8
STUDENTS HELP EVALUATE FACULTY	76.2	74.5	76.2	79.1	74.5	74.0	73.9	77.7	76.5	74.8	74.3	79.0	79.4
ABOLISH COLLEGE GRADES	41.7	40.6	42.2	42.7	40.9	37.3	31.9	44.2	43.7	43.6	46.2	43.4	40.6
DE-EMPHASIZE ORGANIZED SPORTS	26.9	26.6	25.4	29.6	26.8	24.7	23.3	23.1	31.0	28.7	25.2	28.2	34.0
REGULATE STUDENT PUBLICATIONS	32.6	38.9	30.9	23.5	38.1	48.7	30.5	33.6	23.2	33.7	27.7	24.9	18.7
COLLEGE HAS RIGHT TO BAN SPEAKER	29.9	33.5	28.7	25.1	32.9	39.7	37.3	28.3	22.0	29.2	26.6	26.4	21.1
GIVE DISADVANTAGED PREF TRTMT	41.4	46.0	40.3	34.9	45.6	50.7	31.0	43.3	41.1	42.2	36.4	35.4	33.2
COL TOO LAX ON STUDENT PROTEST	49.7	53.9	49.2	42.6	53.6	57.4	63.1	48.6	39.9	48.9	44.8	44.2	37.4
ADOPT OPEN ADMISSIONS AT PUB COL	37.7	47.4	32.6	27.5	48.1	38.7	22.4	35.7	31.6	33.0	36.9	28.2	25.2
USE SAME DEGREE STANDARD FOR ALL	78.5	78.3	78.0	79.7	78.6	75.9	81.8	77.4	77.9	76.8	76.0	78.8	82.5
CURRENT POLITICAL PREFERENCE													
FAR LEFT	3.5	3.1	3.6	4.0	3.2	2.2	1.8	3.2	6.6	4.1	3.4	3.8	4.6
LIBERAL	36.7	32.6	38.0	42.4	32.8	30.4	32.6	37.1	43.1	38.5	41.8	41.1	46.8
MIDDLE-OF-THE-ROAD	43.6	48.2	41.4	38.4	48.3	47.9	41.3	44.5	35.9	38.7	40.4	39.7	33.9
CONSERVATIVE	15.3	15.0	16.1	14.5	14.7	18.2	23.2	14.4	13.7	17.5	13.7	14.7	13.7
FAR RIGHT	.9	1.1	.9	.7	1.1	1.2	1.1	.8	.7	1.2	.7	.7	.9
OBJECTIVES CONSIDERED TO BE ESSENTIAL OR VERY IMPORTANT													
ACHIEVE IN A PERFORMING ART	9.9	8.7	11.4	10.0	8.6	10.6	7.2	11.1	14.0	13.8	10.8	9.3	12.3
BE AN AUTHORITY IN MY FIELD	64.8	63.9	66.5	63.7	63.6	67.3	70.6	66.2	63.8	66.6	66.0	63.3	65.0
OBTAIN RECOGNITION FROM PEERS	42.1	40.0	43.9	43.2	39.8	42.3	48.0	43.5	42.3	41.8	45.6	42.1	46.9
INFLUENCE POLITICAL STRUCTURE	17.3	13.9	19.7	20.0	13.7	15.8	17.0	17.9	24.4	20.9	22.4	18.6	24.6
INFLUENCE SOCIAL VALUES	26.5	23.6	29.3	27.6	23.1	29.6	22.8	27.1	33.8	33.9	36.2	26.3	32.2
RAISE A FAMILY	56.5	56.5	58.5	53.5	56.1	61.5	64.0	56.3	57.2	60.0	60.2	53.2	54.4
HAVE ACTIVE SOCIAL LIFE	56.6	57.1	57.7	54.1	57.1	56.6	56.3	59.5	54.4	55.7	60.5	54.2	53.8
HAVE FRIENDS DIFFERENT FROM ME	57.0	55.8	58.6	57.0	55.7	56.8	54.5	58.6	59.7	58.3	63.9	56.3	59.5
BE AN EXPERT IN FINANCE	19.0	21.1	18.2	16.5	21.1	20.6	14.5	19.9	15.9	18.1	20.7	17.0	14.8
BE ADMINISTRATIVELY RESPONSIBLE	25.2	26.5	26.1	21.6	26.6	25.5	35.1	25.3	22.4	23.9	25.1	21.8	21.0
BE VERY WELL-OFF FINANCIALLY	50.2	54.1	47.9	46.6	54.4	50.6	48.6	51.2	43.4	43.0	47.2	47.7	43.0
HELP OTHERS IN DIFFICULTY	55.2	53.1	58.3	54.3	52.5	59.9	54.0	55.3	61.8	64.2	64.8	52.8	59.3
PARTICIPATE IN PEACE CORPS/VISTA	11.3	10.7	12.3	10.8	10.5	12.5	8.3	11.3	14.6	14.8	15.9	10.7	11.3
BECOME A COMMUNITY LEADER	16.1	13.4	19.8	15.6	12.9	18.7	22.0	18.4	19.2	22.3	19.6	14.8	18.2
CONTRIBUTE TO SCIENTIFIC THEORY	11.9	9.0	12.3	16.4	9.0	10.2	20.7	9.7	12.6	11.3	12.3	15.2	20.3
WRITE ORIGINAL WORKS	11.5	9.1	12.9	13.9	9.1	10.1	9.2	11.4	18.2	14.7	13.9	13.0	16.9
NEVER BE OBLIGATED TO PEOPLE	22.8	24.0	21.8	22.1	24.1	22.2	21.9	22.4	22.3	21.1	19.0	22.3	21.3
CREATE WORKS OF ART	11.2	11.1	10.6	12.4	11.0	12.2	7.3	10.0	14.1	12.4	9.5	12.6	11.8
KEEP UP WITH POLITICAL AFFAIRS	44.8	38.3	48.8	50.5	38.2	39.6	52.8	44.7	51.7	50.3	54.7	48.7	56.2
SUCCEED IN MY OWN BUSINESS	53.0	58.3	49.8	48.1	58.1	61.2	38.0	53.5	48.3	51.3	52.8	49.7	43.0
HELP CLEAN UP ENVIRONMENT	43.9	42.8	44.9	44.5	42.6	45.7	42.9	45.5	46.5	43.6	45.1	44.7	43.7
DEVELOP A PHILOSOPHY OF LIFE	63.6	56.4	68.7	69.0	56.1	59.9	70.5	64.3	73.3	72.7	73.0	67.2	75.2
PARTICIPATE IN COMMUNITY ACTION	23.7	22.0	26.6	22.6	21.8	24.8	22.3	26.6	26.6	29.5	29.6	21.8	25.1
MARRY WITHIN NEXT 5 YEARS	24.2	27.7	23.8	18.6	27.3	32.2	27.6	24.2	19.0	25.3	20.6	19.9	14.3

AMERICAN COUNCIL ON EDUCATION
OFFICE OF RESEARCH FALL 1971
WEIGHTED NATIONAL NORMS FOR FRESHMAN MEN

	All Insti- tutions	All 2-Year Colleges	All 4-Year Colleges	All Uni- versities	2-Year Colleges		4-Year Colleges			Universities			
					Public	Private	Technical Institutions	Public	Private Nonsect.	Prot- estant	Catholic	Public	Private
SELF RATINGS OF BETTER THAN 'AVERAGE' ON PERSONAL TRAITS													
ACADEMIC ABILITY	49.6	31.6	56.5	72.1	31.9	28.5	81.3	45.9	62.8	56.5	54.7	68.6	83.6
ATHLETIC ABILITY	45.8	43.3	49.1	45.4	43.3	43.5	54.2	47.8	48.4	50.0	45.8	45.3	45.8
ARTISTIC ABILITY	16.1	15.3	15.5	18.2	15.3	15.6	15.5	14.1	19.3	16.5	14.0	18.0	19.0
CHEERFULNESS	47.7	46.0	50.1	47.1	46.0	47.0	52.1	49.2	49.3	51.4	49.9	47.0	47.7
DEFENSIVENESS	26.8	26.8	26.7	27.0	26.8	26.5	26.8	26.9	25.9	26.8	26.2	27.1	26.8
DRIVE TO ACHIEVE	51.1	43.0	55.0	59.9	42.8	44.4	72.6	48.5	57.0	55.1	52.1	56.9	69.8
LEADERSHIP ABILITY	38.6	30.3	44.1	45.6	30.2	31.4	62.0	37.1	45.9	46.2	39.9	43.7	52.1
MATHEMATICAL ABILITY	37.6	25.9	40.2	54.8	26.2	22.7	71.7	30.2	42.6	37.8	34.6	51.7	65.2
MECHANICAL ABILITY	34.7	36.0	31.7	36.7	36.3	32.8	47.3	29.3	30.1	27.9	25.1	36.8	36.7
ORIGINALITY	34.8	28.8	37.0	42.5	28.7	29.7	41.1	32.6	44.2	38.5	35.8	40.6	48.7
POLITICAL CONSERVATISM	10.4	7.6	12.1	12.7	7.5	9.2	20.1	9.0	11.7	14.0	11.0	11.8	15.5
POLITICAL LIBERALISM	25.7	19.2	28.0	34.3	19.3	17.2	24.0	25.3	35.6	29.9	31.5	32.6	39.9
POPULARITY (GENERAL)	31.9	27.2	36.1	34.5	27.1	27.5	43.7	33.7	35.8	36.2	34.8	33.7	37.1
POPULARITY WITH OPPOSITE SEX	30.2	26.8	33.6	31.6	26.7	27.7	40.5	31.7	33.3	33.8	30.7	31.6	31.9
PUBLIC SPEAKING ABILITY	21.3	14.7	25.2	27.4	14.4	17.8	31.3	20.6	29.6	28.9	23.0	25.3	34.1
SELF-CONFIDENCE (INTELLECTUAL)	38.7	27.8	43.3	51.7	27.8	27.1	59.5	35.6	47.9	44.6	42.4	48.3	62.9
SELF-CONFIDENCE (SOCIAL)	29.8	26.0	33.2	31.5	26.0	26.1	40.5	30.6	33.0	33.8	32.9	31.0	33.2
SENSITIVITY TO CRITICISM	23.0	20.6	23.7	26.4	20.7	19.4	24.0	21.1	27.1	25.5	26.5	25.2	30.4
STUBBORNNESS	35.4	33.8	35.9	37.7	33.9	31.7	38.7	34.5	36.5	36.0	37.1	37.1	39.9
UNDERSTANDING OF OTHERS	58.4	54.2	61.4	61.7	54.2	53.2	62.3	57.7	66.8	63.8	64.7	60.3	66.1
WRITING ABILITY	26.5	18.7	30.2	34.9	18.8	18.2	34.4	25.4	37.6	32.1	29.6	31.8	45.0
STUDENTS ESTIMATE CHANCES ARE VERY GOOD THAT THEY WILL													
GET MARRIED WHILE IN COLLEGE	7.3	7.2	7.5	7.3	7.0	9.3	4.3	8.9	5.8	8.9	6.1	8.0	4.9
MARRY WITHIN A YEAR AFTER COL	17.8	16.3	19.9	17.4	16.0	19.6	28.4	18.1	16.5	21.2	17.8	18.3	14.3
VOTE IN 1972 PRES ELECTION	75.5	70.9	77.1	81.6	70.8	72.3	78.8	75.6	78.5	76.8	79.2	81.2	83.1
ENLIST IN ARMED SERV BEFORE GRAD	3.2	1.7	5.3	2.6	1.7	1.5	26.2	1.8	1.2	1.3	1.2	2.5	2.7
CHANGE MAJOR FIELD	11.7	8.2	13.1	16.1	8.2	8.2	8.2	12.9	15.8	15.1	13.8	16.2	15.7
CHANGE CAREER CHOICE	11.9	8.5	13.2	16.4	8.5	8.8	7.3	12.7	17.3	15.9	13.7	16.3	16.8
FAIL ONE OR MORE COURSES	2.5	2.4	2.8	2.2	2.3	2.8	1.7	3.4	2.5	2.9	2.2	2.4	1.5
GRADUATE WITH HONORS	5.2	3.5	5.8	7.2	3.5	3.5	9.1	4.1	6.9	6.1	6.6	6.1	10.6
BE ELECTED TO A STUDENT OFFICE	1.6	1.1	2.1	1.6	1.0	1.7	2.9	1.5	2.5	2.7	2.5	1.2	2.6
JOIN SOC FRATERNITY OR SORORITY	12.5	8.9	15.7	14.4	8.4	15.1	25.2	11.4	16.7	18.4	14.1	12.9	19.4
BE ELECTED TO AN HONOR SOCIETY	2.9	1.4	3.5	4.7	1.4	2.1	7.0	1.9	4.5	3.7	3.9	3.8	7.6
MAKE AT LEAST A 'B' AVERAGE	22.2	16.2	23.7	31.0	16.4	14.0	35.9	16.4	28.8	24.0	28.9	27.8	41.3
NEED EXTRA TIME TO GET DEGREE	4.0	4.5	3.5	3.5	4.5	5.3	3.0	3.6	3.4	4.0	3.6	3.9	2.5
WORK AT OUTSIDE JOB	33.4	40.8	27.2	29.2	42.1	25.2	13.9	30.4	26.7	27.0	36.1	30.5	25.2
SEEK VOCATIONAL COUNSELING	10.5	9.2	11.6	11.3	9.2	9.7	9.9	11.3	12.0	10.9	17.0	11.5	10.8
SEEK PERSONAL COUNSELING	6.4	4.9	8.3	6.3	4.7	7.5	10.2	6.8	8.5	8.8	11.1	5.8	8.0
ENROLL IN HONORS COURSE	5.5	2.1	6.3	10.6	2.2	2.1	10.3	3.3	9.6	7.6	6.6	8.3	18.1
GET TUTORING HELP IN COURSES	6.0	4.7	7.9	5.6	4.4	7.7	11.6	6.5	8.4	7.8	7.5	5.5	5.7
AUTHOR A PUBLISHED ARTICLE	4.1	2.6	4.9	5.4	2.6	2.6	3.6	3.7	8.0	6.2	5.2	4.5	8.3
BE MORE SUCCESSFUL THAN MOST	11.7	11.3	11.3	13.2	11.3	10.2	12.2	10.2	12.3	12.0	12.1	13.0	13.6
DROP OUT TEMPORARILY	1.4	1.2	1.5	1.4	1.2	1.0	.9	1.3	2.2	1.9	1.4	1.5	1.3
DROP OUT PERMANENTLY	.7	.8	.8	.5	.8	.7	1.0	.7	.8	.9	.9	.5	.3
TRANSFER TO ANOTHER COLLEGE	10.9	13.4	10.2	7.3	13.2	15.8	3.9	12.5	8.7	11.3	10.8	8.1	4.7
BE SATISFIED WITH MY COLLEGE	52.2	50.0	54.3	53.2	49.5	55.8	63.7	50.3	56.0	54.9	53.3	51.1	60.2

AMERICAN COUNCIL ON EDUCATION
OFFICE OF RESEARCH FALL 1971
WEIGHTED NATIONAL NORMS FOR FRESHMAN MEN

	All Insti- tutions	All 2-Year Colleges	All 4-Year Colleges	All Uni- versities	2-Year Colleges		Technical Institutions	4-Year Colleges				Universities		
					Public	Private		Public	Private Nonsect.	Prot- estant	Catholic	Public	Private	
ACTIVITIES ENGAGED IN BY STUDENTS DURING THE PAST YEAR														
VOTED IN STUDENT ELECTION (3)	61.5	58.4	64.2	62.8	58.0	64.2	64.3	63.9	62.3	66.2	65.9	62.9	62.4	
CAME LATE TO CLASS	54.4	53.8	55.4	54.2	53.6	56.5	50.9	54.7	61.0	57.6	52.4	53.4	56.6	
PLAYED A MUSICAL INSTRUMENT	34.7	30.9	36.4	38.9	30.7	33.3	35.9	33.1	41.6	42.1	33.5	37.6	42.9	
STUDIED IN THE LIBRARY (3)	27.0	23.8	29.4	29.3	23.6	26.6	29.4	28.7	30.6	31.1	27.7	29.0	30.4	
CHECKED OUT A LIBRARY BOOK (3)	35.4	31.2	38.2	38.9	30.7	36.8	37.7	38.0	40.7	39.6	32.2	38.3	40.8	
ARRANGED DATE FOR STUDENT OVERSLEPT AND MISSED A CLASS	44.0	45.5	44.6	40.5	44.9	52.4	39.5	47.6	41.3	45.0	44.4	41.3	37.5	
READ ABOUT RIGHTS/RESPONSIBILITY	24.2	25.2	24.1	22.4	25.3	23.9	17.0	24.6	29.1	24.5	24.4	21.8	24.2	
TYPED A HOMEWORK ASSIGNMENT (3)	63.2	58.4	66.4	66.8	57.8	65.5	60.7	66.5	69.7	69.5	64.6	65.7	70.4	
DISCUSSED FUTURE WITH PARENTS (3)	15.9	13.2	17.5	18.4	13.2	13.0	19.0	15.9	19.3	17.2	20.0	17.2	22.1	
WAS LATE WITH SCHOOL ASSIGNMENT	32.4	31.1	34.7	31.1	30.8	35.1	41.7	31.6	35.4	36.0	34.7	30.2	34.1	
ARGUED WITH A TEACHER IN CLASS	72.3	73.3	72.7	70.0	73.0	77.0	70.4	72.7	73.7	74.7	70.9	70.8	67.2	
ATTENDED A RELIGIOUS SERVICE	55.4	50.1	57.2	62.0	50.3	47.7	51.9	55.4	62.8	60.7	59.7	60.6	66.5	
DEMONSTRATED FOR RACIAL CHANGE	83.5	81.2	86.2	83.5	80.6	88.1	88.1	85.7	80.5	88.2	92.1	83.9	82.2	
DEMONSTRATED FOR MILITARY CHANGE	16.9	15.0	19.0	17.2	15.2	13.4	10.5	18.4	25.6	21.1	20.5	16.3	20.2	
DEMONSTRATED FOR SCHOOL CHANGE	13.3	11.8	14.3	14.6	12.0	9.9	7.6	12.5	23.3	15.4	16.0	13.3	18.9	
DID EXTRA READING FOR COURSE (3)	32.6	29.0	35.5	34.4	29.4	24.6	25.9	34.8	42.3	36.6	42.5	33.0	39.3	
TOOK SLEEPING PILLS	11.8	8.6	13.4	15.1	8.5	9.3	13.5	12.1	16.9	13.5	12.7	13.6	20.2	
TUTORED ANOTHER STUDENT	3.7	3.7	3.6	3.7	3.7	3.9	2.4	3.6	4.2	4.5	3.6	3.8	3.5	
PLAYED CHESS	39.6	29.6	45.0	49.3	29.4	32.3	60.5	38.1	49.3	44.0	46.5	45.5	61.8	
READ POETRY NOT REQUIRED	51.8	46.7	53.8	57.8	46.8	46.4	64.8	50.2	54.2	53.6	51.8	56.7	61.3	
TOOK A TRANQUILIZING PILL	45.5	39.7	50.1	49.3	39.2	45.9	47.5	47.4	56.3	54.5	48.6	47.7	54.6	
DISCUSSED RELIGION (3)	4.5	4.8	4.3	4.2	4.7	5.3	2.7	4.2	5.3	5.1	4.4	4.1	4.4	
TOOK VITAMINS	20.4	15.7	24.1	23.6	15.0	23.3	22.8	20.4	27.0	30.8	27.9	22.3	27.7	
VISITED ART GALLERY OR MUSEUM	54.7	52.4	56.9	55.5	52.0	56.8	58.5	54.5	58.9	60.9	55.7	55.1	56.8	
PARTICIPATED IN H.S. POL. CMPG.	62.4	59.2	63.2	67.1	59.1	60.0	62.9	60.3	69.3	65.8	62.1	65.7	71.8	
PARTICIPATED IN OTHER POL. CMPG.	34.6	28.3	39.6	38.4	27.5	37.1	41.3	37.2	39.7	42.8	42.5	37.1	42.6	
MISSED SCHOOL DUE TO ILLNESS (3)	12.0	8.8	14.0	14.7	8.5	12.1	13.1	12.2	18.4	14.4	16.5	13.2	19.7	
SMOKED CIGARETTES (3)	2.1	2.5	1.9	1.8	2.5	2.1	1.1	1.9	2.4	2.2	2.2	1.8	2.0	
DISCUSSED POLITICS (3)	16.8	21.2	14.5	12.3	21.3	19.6	7.7	16.4	14.7	13.2	19.4	12.8	10.6	
DRANK BEER	23.7	17.4	26.6	30.5	17.2	20.1	28.1	22.6	32.9	28.7	29.4	28.3	37.9	
DISCUSSED SPORTS (3)	71.0	73.6	68.9	69.6	74.9	58.5	68.4	69.8	67.5	62.1	80.6	70.3	67.6	
READ ABOUT CIVIL RIGHTS	53.6	50.9	58.1	51.9	50.5	55.7	60.2	58.9	52.6	59.1	59.2	52.6	49.7	
ASKED TEACHER FOR ADVICE (3)	79.1	73.7	82.8	83.1	73.4	77.1	83.2	81.4	83.9	85.5	82.4	82.3	85.8	
HAD VOCATIONAL COUNSELING	20.0	16.4	23.0	22.1	16.1	20.5	21.0	20.8	26.8	26.6	24.2	20.7	26.8	
STAYED UP ALL NIGHT	45.2	47.8	45.1	40.6	47.5	50.9	43.2	47.3	38.8	43.3	53.2	42.0	35.8	
	60.4	60.3	60.7	60.1	60.7	56.7	54.2	63.3	60.9	59.7	60.2	60.3	59.2	

(**) THIS ITEM IS REPORTED FOR THE FIRST TIME IN 1971. ITEMS NOT INDICATED WITH '**' ARE REPEATED OR MODIFIED QUESTIONS FROM ONE OR MORE OF THE EARLIER SURVEYS.

(1) SINCE IT IS POSSIBLE THAT SOME STUDENTS MAY HAVE CHECKED MORE THAN ONE RESPONSE CATEGORY FOR THIS ITEM, THE PERCENTAGES MAY SUM TO MORE THAN 100.

(2) RECATEGORIZATION OF THIS ITEM FROM A LONGER LIST IS SHOWN IN APPENDIX C OF THE 1971 NAT'L NORMS REPORT.

(3) FREQUENTLY ONLY, ALL OTHER ITEMS FREQUENTLY PLUS OCCASIONALLY.

**AMERICAN COUNCIL ON EDUCATION
OFFICE OF RESEARCH FALL 1971
WEIGHTED NATIONAL NORMS FOR FRESHMAN WOMEN**

	All Insti- tutions	All 2-Year Colleges	All 4-Year Colleges	All Uni- versities	2-Year Colleges		4-Year Colleges					Universities		
					Public	Private	Technical Institutions	Public	Private Nonsect.	Prot- estant	Catholic	Public	Private	
AGE BY DECEMBER 31, 1971														
16 OR YOUNGER	.1	.0	.1	.2	.0	.1	.4	.0	.3	.1	.1	.1	.1	.3
17	4.3	2.6	4.8	5.9	2.5	3.9	6.5	3.4	8.5	5.4	4.9	5.0	9.9	
18	78.4	72.0	81.6	82.7	71.5	75.9	83.3	81.9	80.5	80.5	83.6	82.9	81.9	
19	12.8	16.5	11.3	9.6	16.5	16.8	3.9	12.3	9.1	12.0	9.5	10.3	6.8	
20	1.4	2.6	.9	.6	2.7	1.6	1.5	.9	.7	1.0	.8	.7	.3	
21	.5	1.0	.3	.2	1.1	.2	.8	.3	.2	.3	.2	.3	.1	
22-25	.9	1.6	.5	.4	1.8	.4	1.9	.4	.4	.5	.4	.5	.3	
26 OR OLDER	1.6	3.6	.5	.4	4.0	1.1	1.8	.7	.2	.2	.5	.4	.3	
FATHER'S EDUCATION														
GRAMMAR SCHOOL OR LESS	8.8	12.3	7.6	5.2	12.9	8.1	14.0	8.8	4.8	6.0	7.2	5.5	3.5	
SOME HIGH SCHOOL	14.9	18.5	14.4	9.9	19.1	14.5	21.9	17.3	9.5	10.7	10.9	10.7	6.6	
HIGH SCHOOL GRADUATE	29.7	33.7	28.9	24.6	34.6	27.7	35.2	32.8	20.4	23.6	29.4	26.2	17.3	
SOME COLLEGE	17.4	16.7	17.4	18.4	16.6	17.2	13.9	18.0	16.3	16.1	18.9	19.0	15.9	
COLLEGE DEGREE	19.4	14.4	20.0	26.1	13.3	22.5	12.5	16.4	26.6	25.4	21.3	25.4	29.2	
POSTGRADUATE DEGREE	10.0	4.4	11.7	15.8	3.6	10.0	2.5	6.6	22.3	18.2	12.4	13.1	27.6	
MOTHER'S EDUCATION														
GRAMMAR SCHOOL OR LESS	5.4	8.2	4.2	3.0	8.6	5.4	9.8	4.8	2.6	3.5	4.2	3.2	2.3	
SOME HIGH SCHOOL	13.2	17.5	12.2	8.3	18.2	12.6	19.0	14.8	7.8	8.7	9.7	9.0	5.3	
HIGH SCHOOL GRADUATE	42.6	45.9	41.5	39.3	46.7	39.8	45.6	45.8	32.0	34.1	45.4	41.6	29.2	
SOME COLLEGE	19.3	15.5	20.3	23.6	14.9	19.6	17.3	19.2	22.3	21.9	20.2	23.4	24.4	
COLLEGE DEGREE	16.2	11.3	17.6	21.2	10.2	19.7	6.8	13.1	25.8	25.5	17.3	19.2	29.9	
POSTGRADUATE DEGREE	3.4	1.7	4.2	4.6	1.5	2.9	1.5	2.3	9.4	6.2	3.2	3.5	9.0	
RACIAL BACKGROUND (1)														
WHITE/CAUCASIAN	90.6	91.1	88.5	93.2	90.4	96.4	94.7	88.5	84.3	89.9	93.0	93.6	91.5	
BLACK/NEGRO/AFRO-AMERICAN	7.2	5.4	10.1	5.0	5.9	1.8	3.6	10.5	14.1	9.0	3.4	4.8	6.1	
AMERICAN INDIAN	.9	.9	.9	1.1	.9	.9	1.5	.8	1.1	.8	.6	1.2	.8	
ORIENTAL	.4	.3	.4	.8	.3	.4	.3	.2	.9	.3	.7	.7	1.3	
MEXICAN-AMERICAN/CHICANO	1.1	2.4	.3	.3	2.7	.2	.0	.1	.3	.3	2.0	.3	.4	
PUERTO RICAN-AMERICAN	.2	.1	.3	.2	.1	.2	1.5	.3	.3	.1	.4	.1	.5	
OTHER	1.1	1.3	1.0	1.1	1.2	1.7	1.2	.9	1.3	.7	1.6	1.2	.9	
ESTIMATED PARENTAL INCOME														
LESS THAN \$4,000	5.9	8.1	5.6	3.1	8.3	6.1	5.9	6.4	4.4	4.8	4.1	3.3	2.6	
\$4,000 - \$5,999	7.2	8.5	7.3	4.7	8.7	6.8	9.3	8.1	5.8	7.0	5.5	4.9	4.1	
\$6,000 - \$7,999	9.8	11.5	9.7	7.1	11.9	8.4	12.8	10.7	7.6	9.2	8.5	7.6	5.0	
\$8,000 - \$9,999	12.1	13.6	11.9	9.9	14.1	10.0	19.1	13.4	8.8	10.0	10.6	10.5	7.0	
\$10,000 - \$12,499	17.7	19.2	16.6	17.2	19.9	14.0	14.0	18.2	12.2	15.1	18.0	18.5	11.9	
\$12,500 - \$14,999	13.6	13.1	13.6	14.6	13.3	11.6	15.0	14.4	11.3	12.4	14.7	15.6	10.6	
\$15,000 - \$19,999	13.9	12.4	14.0	16.4	12.3	13.0	12.1	13.8	14.5	13.7	14.5	16.9	14.5	
\$20,000 - \$24,999	8.4	6.5	8.6	11.0	6.1	9.3	6.3	7.6	11.1	9.6	8.9	10.6	12.7	
\$25,000 - \$29,999	4.0	2.6	4.3	5.7	2.2	5.7	3.6	3.1	6.5	5.8	5.0	5.0	8.6	
\$30,000 - \$34,999	2.7	1.8	3.0	3.6	1.4	4.9	1.4	1.9	5.1	4.4	3.5	3.0	6.1	
\$35,000 - \$39,999	1.5	.9	1.6	2.0	.7	3.1	.0	.9	3.2	2.5	2.1	1.4	4.5	
\$40,000 OR MORE	3.3	1.8	3.8	4.7	1.1	7.2	.5	1.6	9.5	5.5	4.7	2.9	12.4	

**AMERICAN COUNCIL ON EDUCATION
OFFICE OF RESEARCH FALL 1971
WEIGHTED NATIONAL NORMS FOR FRESHMAN WOMEN**

	All Insti- tutions	All 2-Year Colleges	All 4-Year Colleges	All Uni- versities	2-Year Colleges		Technical Institutions	4-Year Colleges				Universities		
					Public	Private		Public	Private Nonsect.	Prot- estant	Catholic	Public	Private	
RELIGION REARED														
PROTESTANT	52.2	49.7	54.6	51.9	49.1	54.1	19.8	57.6	51.6	76.8	10.2	53.6	44.8	
ROMAN CATHOLIC	33.3	36.6	31.2	31.8	38.7	21.3	72.2	29.1	22.8	10.2	86.8	32.2	30.4	
JEWISH	3.6	1.9	3.0	7.5	1.7	3.9	3.3	1.4	10.6	1.7	.4	5.0	18.0	
OTHER	9.0	10.1	9.6	6.2	8.8	18.8	3.9	10.5	11.4	9.5	1.8	6.7	3.9	
NONE	1.9	1.8	1.7	2.5	1.7	1.9	.8	1.3	3.6	1.9	.8	2.4	2.9	
RELIGIOUS PREFERENCE														
PROTESTANT	44.8	42.9	47.4	42.9	42.3	47.8	13.9	51.5	39.1	68.2	8.2	44.7	35.3	
ROMAN CATHOLIC	28.7	33.0	26.7	25.7	35.0	18.1	54.0	25.5	16.9	7.9	78.8	26.0	24.5	
JEWISH	2.9	1.6	2.2	6.0	1.4	3.3	3.0	1.1	7.7	1.4	.3	3.9	14.7	
OTHER	11.4	12.4	11.8	8.9	11.2	21.1	8.5	12.3	14.8	11.6	4.5	9.3	7.0	
NONE	12.2	10.0	11.9	16.4	10.0	9.8	20.7	9.5	21.5	10.9	8.1	16.0	18.5	
FATHER'S OCCUPATION (2)														
ARTIST (INCL PERFORMER)	.8	.8	.8	.9	.7	1.0	1.1	.6	1.4	.9	.9	.9	1.1	
BUSINESSMAN	29.7	26.7	30.5	33.1	25.4	35.9	27.4	27.2	36.5	32.4	35.9	31.8	39.0	
CLERGYMAN	.9	.6	1.3	.6	.5	1.9	.0	.7	1.7	4.0	.2	.6	.9	
COLLEGE TEACHER	.9	.5	.9	1.3	.5	.4	.2	.4	1.9	1.8	.7	1.1	2.3	
DOCTOR (M.D. OR D.D.S.)	2.0	.8	2.2	3.3	.6	2.5	.5	.8	5.0	3.8	3.4	2.2	8.1	
EDUCATOR (SECONDARY)	2.3	1.8	2.9	2.2	1.7	2.0	1.5	2.9	2.8	3.4	2.0	2.3	1.6	
ELEMENTARY TEACHER	.4	.3	.4	.3	.3	.4	.4	.4	.4	.5	.4	.4	.2	
ENGINEER	7.5	6.3	7.1	10.2	6.3	6.5	5.0	6.9	7.9	7.3	6.8	10.6	8.8	
FARMER OR FORESTER	6.8	9.1	5.5	5.6	9.6	6.0	1.2	6.4	2.3	7.2	3.6	6.5	2.0	
HEALTH PROFESSIONAL (NON-M.D.)	1.2	1.0	1.2	1.5	1.0	1.0	1.5	1.1	1.4	1.2	1.2	1.4	1.6	
LAWYER	1.3	.6	1.4	2.1	.4	2.0	.0	.6	3.1	1.6	2.5	1.4	4.7	
MILITARY CAREER	1.8	1.7	1.9	1.9	1.6	2.3	1.1	2.3	1.3	1.6	1.2	2.0	1.4	
RESEARCH SCIENTIST	.6	.3	.6	1.2	.2	.4	.8	.4	.9	.9	.6	1.2	1.5	
SKILLED WORKER	11.0	13.0	10.4	9.0	13.6	8.3	19.7	11.8	7.6	6.9	11.0	9.5	6.8	
SEMI-SKILLED WORKER	6.7	8.1	6.3	5.1	8.7	4.1	7.8	7.6	4.1	4.4	5.3	5.6	3.2	
UNSKILLED WORKER	3.8	4.6	3.8	2.7	4.9	2.2	6.0	4.5	2.6	2.7	3.0	2.9	1.7	
UNEMPLOYED	1.7	2.1	1.5	1.2	2.1	1.8	1.4	1.7	1.5	1.3	1.3	1.3	.8	
OTHER	20.7	21.8	21.3	17.7	21.8	21.4	24.4	23.5	17.8	17.9	20.1	18.5	14.3	
VETERAN														
NO	99.8	99.8	99.7	99.9	99.8	100.0	100.0	99.5	99.9	99.9	99.9	99.9	100.0	
YES, SERVED IN SOUTHEAST ASIA	.0	.0	.0	.0	.0	.0	.0	.0	.0	.0	.0	.0	.0	
YES, DID NOT SERVE IN SE ASIA	.2	.2	.3	.1	.2	.0	.0	.5	.1	.1	.1	.1	.0	
MARITAL STATUS **														
PRESENTLY MARRIED	2.6	4.7	1.5	1.2	5.0	2.2	2.6	1.8	.8	1.0	1.2	1.3	.6	
NOT MARRIED	97.4	95.3	98.5	98.8	95.0	97.8	97.4	98.2	99.2	99.0	98.8	98.7	99.4	
DISTANCE FROM HOME TO COLLEGE														
5 MILES OR LESS	11.6	19.5	7.2	6.8	21.1	8.3	13.3	7.1	4.5	6.1	13.2	7.0	6.0	
6-10 MILES	11.2	17.7	6.0	10.2	19.3	6.1	23.4	5.1	5.5	3.3	13.0	10.7	7.9	
11-50 MILES	26.9	36.8	21.5	21.0	38.9	21.4	38.3	25.2	13.5	13.4	24.5	21.9	17.1	
51-100 MILES	15.3	11.3	18.5	16.0	10.3	18.1	15.4	21.5	11.6	18.3	13.6	18.0	7.2	
101-500 MILES	28.4	12.8	36.5	38.6	9.9	33.6	8.2	37.2	40.2	39.2	26.2	38.6	38.6	
MORE THAN 500 MILES	6.7	1.9	10.4	7.5	.5	12.5	1.4	3.8	24.7	19.7	9.5	3.8	23.3	

**AMERICAN COUNCIL ON EDUCATION
OFFICE OF RESEARCH FALL 1971
WEIGHTED NATIONAL NORMS FOR FRESHMAN WOMEN**

	All Insti- tutions	All 2-Year Colleges	All 4-Year Colleges	All Uni- versities	2-Year Colleges		4-Year Colleges					Universities	
					Public	Private	Technical Institutions	Public	Private Nonsect.	Prot- estant	Catholic	Public	Private
AVERAGE GRADE IN HIGH SCHOOL													
A OR A+	7.4	3.1	7.4	13.9	3.2	2.4	6.5	5.6	10.9	10.0	7.7	11.3	25.0
A-	12.0	6.7	12.9	18.9	6.9	4.7	9.2	10.8	17.2	15.7	13.2	17.9	23.5
B+	21.7	15.8	24.0	26.9	16.4	11.1	30.2	23.5	26.1	23.3	23.9	27.6	24.1
B	28.1	30.4	28.4	24.1	31.2	24.4	31.9	29.8	25.2	26.2	29.6	25.8	16.8
B-	13.9	17.4	13.5	9.2	17.2	19.3	14.5	15.0	10.5	11.3	13.7	9.9	6.2
C+	10.8	16.3	9.1	5.3	15.7	21.1	6.5	10.4	6.5	8.3	8.0	5.7	3.3
C	5.8	9.9	4.4	1.7	9.0	16.2	.7	4.8	3.3	5.0	3.8	1.9	1.1
D	.2	.4	.2	.1	.4	.9	.4	.1	.2	.2	.1	.1	.0
RANK IN HIGH SCHOOL CLASS													
TOP QUARTER	49.7	29.3	55.6	70.6	30.1	23.3	46.7	54.5	60.7	58.9	49.1	69.0	77.8
SECOND QUARTER	30.4	35.9	30.1	22.4	36.1	34.9	43.1	31.6	25.8	26.7	32.3	23.7	17.1
THIRD QUARTER	17.5	30.3	12.7	6.3	29.4	36.5	9.1	12.6	11.7	12.7	16.4	6.6	4.7
FOURTH QUARTER	2.4	4.5	1.6	.7	4.4	5.3	1.1	1.4	1.9	1.7	2.2	.8	.4
SECONDARY SCHOOL ACHIEVEMENTS													
PRESIDENT STUDENT ORGANIZATION	18.4	13.6	20.4	22.2	13.2	16.4	11.5	18.8	23.0	23.5	21.9	20.9	27.9
HIGH RATING STATE MUSIC CONTEST	12.2	10.2	12.7	14.4	10.5	8.4	1.6	12.2	12.1	18.2	8.9	15.0	12.0
STATE/REGIONAL SPEECH CONTEST	5.0	3.2	5.6	6.5	3.3	2.5	2.7	5.2	5.7	6.4	7.3	6.3	7.2
MAJOR PART IN A PLAY	15.4	12.5	17.2	16.7	12.5	13.0	10.9	15.9	19.5	20.2	16.6	16.2	18.7
VARSITY LETTER (SPORTS)	16.0	15.1	16.7	16.0	14.6	18.7	11.1	17.1	16.8	16.8	14.6	16.2	15.4
AWARD IN ART COMPETITION	6.4	5.6	6.6	7.1	5.4	7.1	12.2	5.8	8.3	6.9	7.5	7.1	7.3
EDITOR OF SCHOOL PAPER	15.5	12.1	16.8	18.5	11.9	13.5	13.3	15.7	19.5	17.6	18.0	17.2	24.1
ORIGINAL WRITING PUBLISHED	18.1	13.2	20.1	22.1	12.9	15.9	22.4	17.4	25.2	22.4	22.6	20.5	29.1
NSF SUMMER PROGRAM	.6	.3	.6	1.1	.3	.2	1.4	.4	1.0	.8	.5	.7	2.5
STATE/REGIONAL SCIENCE PROGRAM	1.7	1.3	1.8	2.0	1.3	1.2	2.1	1.6	1.9	2.2	1.8	1.8	3.2
SCHOLASTIC HONOR SOCIETY	31.5	16.4	35.6	48.3	16.8	13.2	32.9	33.2	39.7	40.5	34.0	46.5	55.8
NATIONAL MERIT RECOGNITION	8.0	3.7	8.8	13.2	3.9	2.2	9.1	5.9	18.6	9.1	8.2	10.2	25.8
YEAR FINISH SECONDARY SCHOOL **													
GRADUATED IN 1971	92.6	87.2	95.4	96.2	86.4	92.6	94.0	95.5	95.3	94.9	96.0	96.1	96.8
DID NOT GRADUATE IN 1971	7.4	12.8	4.6	3.8	13.6	7.4	6.0	4.5	4.7	5.1	4.0	3.9	3.2
HIGHEST DEGREE PLANNED													
NONE	6.6	11.6	4.3	2.9	12.1	7.7	3.4	4.3	4.1	4.4	4.5	3.1	2.1
ASSOCIATE (OR EQUIVALENT)	12.5	30.9	2.5	1.7	32.1	21.8	.3	3.1	1.2	2.9	1.1	2.0	.6
BACHELOR'S (B.A., B.S.)	41.8	31.4	47.2	48.6	30.0	41.2	49.9	50.6	37.9	45.4	46.1	51.7	35.2
MASTER'S (M.A., M.S.)	26.6	15.8	33.7	30.3	15.3	20.0	35.0	33.5	35.5	32.0	34.8	29.7	32.6
PH.D. OR ED.D.	5.2	2.1	6.4	7.9	1.9	3.0	7.6	4.5	11.6	7.5	6.0	6.5	13.8
M.D., D.O., D.D.S., OR D.V.M.	2.6	1.4	2.3	4.9	1.5	1.2	2.6	1.1	4.5	3.4	3.1	3.7	10.0
LL.B. OR J.D. (LAW)	1.2	.4	1.5	1.9	.4	.9	.4	.9	3.2	1.8	1.9	1.3	4.6
R.D. (DIVINITY)	.1	.1	.1	.0	.1	.0	.0	.0	.1	.3	.0	.0	.0
OTHER	3.5	6.3	2.1	1.7	6.6	4.1	.7	2.0	2.0	2.2	2.6	1.9	1.0
CONCERN ABOUT FINANCING COLLEGE													
NO CONCERN	32.4	37.1	29.2	30.6	36.4	42.2	26.8	27.4	33.7	32.9	25.6	29.1	37.2
SOME CONCERN	56.4	54.5	57.9	56.7	55.1	50.0	65.0	59.5	53.5	55.1	60.2	57.8	51.9
MAJOR CONCERN	11.2	8.4	12.9	12.7	8.5	7.8	8.2	13.1	12.8	12.0	14.2	13.1	10.9

**AMERICAN COUNCIL ON EDUCATION
OFFICE OF RESEARCH FALL 1971
WEIGHTED NATIONAL NORMS FOR FRESHMAN WOMEN**

	All Insti- tutions	All 2-Year Colleges	All 4-Year Colleges	All Uni- versities	2-Year Colleges		Technical Institutions	4-Year Colleges				Universities	
					Public	Private		Public	Private Nonsect.	Prot- estant	Catholic	Public	Private
MAJOR SOURCES OF FINANCIAL SUPPORT FOR COLLEGE (1)													
PART-TIME OR SUMMER WORK	22.8	26.0	20.2	22.5	27.7	13.4	44.7	22.3	13.9	15.3	23.1	24.6	13.4
SAVINGS FROM FULL-TIME EMPLOY	6.9	9.1	5.3	6.3	9.7	4.8	13.6	5.6	3.8	4.5	5.8	6.8	3.8
PARENTAL OR FAMILY AID OR GIFTS	61.2	53.0	63.9	69.4	51.1	67.0	46.4	60.9	71.8	70.4	59.9	67.9	75.6
PARENT'S MILITARY SERVICE	1.8	2.0	1.8	1.5	2.0	2.4	2.1	2.0	1.5	1.6	1.6	1.6	.9
PERSONAL MILITARY SERVICE	.2	.2	.1	.1	.2	.1	.4	.2	.1	.1	.1	.1	.1
SCHOLARSHIPS AND GRANTS	20.5	15.5	25.1	19.9	15.0	19.1	19.0	22.0	27.4	29.5	32.9	17.7	29.5
LOANS-NDEA/GOV'T INSURED/COLLEGE	15.9	13.1	19.4	14.0	12.5	17.7	5.0	16.6	21.7	23.9	26.5	12.9	18.6
OTHER REPAYABLE LOANS	7.0	6.4	8.9	4.5	6.1	8.6	3.2	9.2	8.8	8.2	9.3	4.6	4.3
PROBABLE MAJOR FIELD OF STUDY(2)													
AGRICULTURE (INCL FORESTRY)	.7	1.5	.2	.5	1.7	.0	.0	.2	.3	.2	.1	.6	.1
BIOLOGICAL SCIENCES	2.7	1.3	3.1	4.1	1.3	1.1	8.6	2.4	4.4	3.8	3.0	3.9	5.2
BUSINESS	14.2	27.9	7.3	5.1	28.8	21.4	4.3	9.1	4.7	5.7	4.0	5.8	2.1
EDUCATION	15.9	12.9	20.8	11.8	12.3	17.3	7.9	26.8	10.5	16.1	14.4	13.0	6.7
ENGINEERING	.3	.1	.2	.6	.2	.0	4.5	.1	.2	.1	.3	.4	1.2
ENGLISH	3.5	2.2	4.2	4.0	2.2	2.7	2.6	3.7	4.9	4.9	5.5	3.8	5.1
HEALTH PROFESSIONS (NON-M.D.)	16.1	20.7	12.8	14.6	21.9	12.1	9.2	13.6	9.1	10.4	19.9	14.6	14.8
HISTORY, POLITICAL SCIENCE	3.1	1.8	4.1	3.5	1.7	2.5	3.8	3.4	6.3	3.6	4.8	2.9	5.7
HUMANITIES (OTHER)	4.2	2.5	5.1	5.4	2.3	3.6	5.6	3.7	7.4	6.9	5.9	4.9	7.4
FINE ARTS	9.7	6.6	11.2	11.8	5.9	11.8	18.7	9.0	15.5	14.0	9.8	12.0	11.3
MATHEMATICS OR STATISTICS	2.9	1.2	3.7	4.0	1.2	1.2	5.3	3.4	3.6	3.6	4.8	3.7	5.6
PHYSICAL SCIENCES	.8	.4	.9	1.3	.4	.2	2.1	.8	1.1	1.1	.9	1.2	1.9
PRE-PROFESSIONAL	3.9	2.8	3.5	6.6	2.8	2.1	2.1	2.1	6.3	4.7	4.3	5.1	13.0
SOCIAL SCIENCES	12.2	8.9	14.4	13.5	8.2	14.4	23.0	11.8	18.9	17.2	15.8	13.3	14.3
OTHER FIELDS (TECHNICAL)	2.6	3.3	2.1	2.4	3.4	2.6	1.3	2.2	2.0	1.8	1.8	2.5	2.0
OTHER FIELDS (NONTECHNICAL)	5.0	3.9	4.2	8.0	3.8	4.7	.8	5.4	2.3	3.4	3.2	9.6	.9
UNDECIDED	2.3	1.9	2.3	2.7	1.9	2.3	.0	2.4	2.4	2.5	1.5	2.8	2.5
PROBABLE CAREER OCCUPATION (2)													
ARTIST (INCL PERFORMER)	7.2	4.8	7.9	9.8	4.2	9.0	14.9	6.1	11.9	9.2	7.8	10.1	8.9
BUSINESSMAN	4.4	6.8	3.2	2.9	7.0	5.1	3.5	3.6	2.7	2.5	3.0	3.2	1.8
CLERGYMAN	.2	.1	.3	.1	.1	.4	.0	.1	.3	1.3	.2	.1	.2
COLLEGE TEACHER	.6	.3	.7	.8	.3	.6	.9	.6	1.1	.9	.5	.7	1.4
DOCTOR (M.D. OR D.D.S.)	2.0	1.0	1.9	3.8	1.0	.9	1.7	.9	3.8	2.8	2.8	2.6	9.0
EDUCATOR (SECONDARY)	11.0	7.0	14.7	10.6	6.9	7.9	9.6	17.7	9.5	12.5	10.6	11.5	7.0
ELEMENTARY TEACHER	13.8	11.7	18.0	9.2	10.9	17.8	12.2	22.3	8.9	14.9	15.8	10.1	5.5
ENGINEER	.2	.1	.2	.5	.1	.1	4.5	.1	.1	.2	.4	.4	1.1
FARMER OR FORESTER	.7	.9	.4	.7	1.0	.3	.4	.3	.8	.4	.3	.8	.5
HEALTH PROFESSIONAL (NON-M.D.)	8.8	8.6	7.8	11.0	8.9	6.5	2.6	8.3	8.1	6.7	7.3	12.3	5.6
LAWYER	1.4	.5	1.7	2.1	.5	.7	.4	1.1	3.4	2.0	2.2	1.4	4.9
NURSE	8.6	12.2	6.4	6.9	12.9	6.8	8.3	6.4	2.9	5.0	14.2	6.3	9.8
RESEARCH SCIENTIST	1.5	.5	1.6	2.9	.5	.6	8.1	1.0	2.8	2.0	1.7	2.5	4.3
OTHER	26.1	34.9	21.3	21.1	35.4	31.6	21.4	20.2	24.0	22.9	20.6	21.7	18.6
UNDECIDED	13.5	10.5	13.8	17.5	10.4	11.7	11.7	11.4	19.8	16.8	12.8	16.5	21.5

**AMERICAN COUNCIL ON EDUCATION
OFFICE OF RESEARCH FALL 1971
WEIGHTED NATIONAL NORMS FOR FRESHMAN WOMEN**

	All Insti- tutions	All 2-Year Colleges	All 4-Year Colleges	All Uni- versities	2-Year Colleges		4-Year Colleges					Universities	
					Public	Private	Technical Institutions	Public	Private Nonsect.	Prot- estant	Catholic	Public	Private
REASONS NOTED AS VERY IMPORTANT IN DECIDING TO GO TO COLLEGE **													
PARENTS WANTED ME TO GO	24.1	23.6	25.4	22.7	22.6	30.5	17.1	24.2	26.3	30.1	23.8	22.5	23.9
CONTRIBUTE MORE TO MY COMMUNITY	23.1	20.5	25.1	23.6	20.6	19.7	20.8	23.7	26.8	25.2	30.4	22.2	29.4
GET A BETTER JOB	70.1	77.6	66.9	63.7	78.1	73.7	60.1	73.0	56.6	60.3	62.3	66.1	53.8
GAIN A GENERAL EDUCATION	66.8	61.1	69.0	71.8	60.2	67.8	67.5	65.8	75.6	71.8	71.2	70.1	79.3
IMPROVE READING/STUDY SKILLS	22.7	24.7	22.8	19.5	24.0	29.7	16.7	23.1	22.3	23.5	21.3	19.7	18.8
NOTHING BETTER TO DO	2.3	2.2	2.2	2.5	2.2	2.0	2.3	2.1	2.9	2.2	1.6	2.5	2.3
BECOME MORE CULTURED	34.0	31.7	35.8	34.2	30.8	38.6	33.7	33.9	38.1	38.3	38.6	33.6	36.9
MAKE MORE MONEY	41.5	51.9	36.8	33.6	53.0	44.0	29.0	42.7	28.7	30.2	29.6	35.7	24.5
LEARN MORE ABOUT MY INTERESTS	73.9	70.3	74.5	78.7	70.5	68.6	76.7	72.3	80.3	74.7	76.2	77.5	83.9
MEET NEW/INTERESTING PEOPLE	55.3	50.8	56.8	59.9	49.7	58.5	50.3	54.4	62.2	58.1	60.3	58.7	64.7
PREPARE FOR GRAD OR PROF SCHOOL	29.3	30.2	28.8	28.7	29.4	35.7	24.7	26.3	34.4	31.1	29.6	26.4	38.6
REASONS NOTED AS VERY IMPORTANT IN SELECTING THIS COLLEGE **													
RELATIVES WANTED ME TO GO	9.5	10.7	9.3	8.1	10.6	11.7	7.7	9.0	8.3	11.6	9.6	8.4	6.6
COLLEGE HAS A GOOD REPUTATION	37.7	31.4	40.3	43.0	29.7	44.4	20.1	34.8	47.0	51.6	45.2	39.8	56.6
MOST FRIENDS GOING TO THIS COL	4.5	6.0	3.5	4.0	6.4	3.3	.4	4.9	1.6	2.1	1.6	4.8	.7
LOW TUITION	18.7	25.5	12.9	18.3	28.2	5.2	38.0	19.0	4.7	2.9	4.8	22.1	2.2
ADVICE OF SOMEONE WHO ATTENDED	16.2	16.2	16.7	15.2	15.6	20.6	10.0	16.3	15.0	20.4	17.2	15.9	12.3
SPECIAL EDUC PROGRAM OFFERED	35.9	36.4	36.3	34.2	36.4	36.6	43.0	34.0	43.9	35.4	37.3	31.7	45.1
NOT ACCEPTED ANYWHERE ELSE	2.5	3.1	2.3	2.0	3.0	3.4	2.3	2.3	2.5	1.8	2.6	2.1	1.5
ADVICE OF GUIDANCE COUNSELOR	6.6	9.0	6.1	3.8	8.4	13.4	4.9	5.7	6.5	6.3	7.0	3.5	5.0
WANTED TO LIVE AT HOME	12.2	21.1	6.4	8.2	22.9	7.8	19.5	7.0	4.1	3.4	10.2	9.1	4.3
NEED FOR SPECIAL HELP IN (1) **													
ENGLISH	10.8	12.4	10.5	8.9	11.9	16.0	8.7	10.8	11.0	9.4	9.6	9.6	5.9
READING	8.3	9.0	7.4	8.9	8.7	11.2	7.8	6.8	8.1	8.8	7.0	9.4	6.8
MATHEMATICS	38.4	38.6	41.0	33.3	37.7	45.2	27.3	42.9	38.1	39.5	40.0	34.7	27.6
SOCIAL STUDIES	4.2	4.8	4.4	3.1	4.8	4.8	6.8	4.4	4.1	4.0	4.6	3.2	2.4
SCIENCE	26.8	23.3	29.4	27.6	22.9	26.5	23.7	30.1	27.6	28.5	31.4	28.4	23.9
FOREIGN LANGUAGE	16.7	13.7	19.8	15.9	12.6	22.1	19.9	16.9	22.3	24.6	24.3	16.4	13.9
AGREE STRONGLY OR SOMEWHAT													
GOV'T NOT CONTROLLING POLLUTION	90.8	88.7	91.5	92.9	88.6	90.0	90.2	91.1	92.7	91.4	91.6	92.5	94.5
GOV'T NOT PROTECTING CONSUMER	77.2	75.3	77.6	79.3	75.2	76.0	79.8	76.2	81.9	77.8	77.7	78.6	82.2
GOV'T NOT DESEGREGATING QUICKLY	53.0	53.0	52.3	54.3	53.5	48.6	60.1	49.9	60.0	50.8	54.0	53.3	58.6
TOO MANY RIGHTS FOR CRIMINALS	41.1	44.1	39.8	38.9	44.3	42.6	36.9	42.3	32.6	40.2	37.2	40.2	33.6
SHOULD ABOLISH DEATH PENALTY	62.8	58.1	65.1	66.0	57.8	59.8	76.9	63.6	68.6	62.7	70.1	65.1	70.3
WOMEN'S ACTIVITIES BEST IN HOME	30.6	35.4	30.6	22.9	34.7	40.4	22.7	32.3	24.6	32.3	30.0	24.2	17.1
BARELY COMMUNICATE WITH PARENTS	16.3	17.7	15.1	16.1	18.1	15.4	19.9	16.0	14.1	12.9	14.2	16.6	14.3
SHOULD LEGALIZE MARIJUANA	35.0	30.8	34.5	42.8	30.3	34.5	55.0	31.0	45.8	32.1	35.1	41.4	48.9
SHOULD DISCOURAGE LARGE FAMILIES	67.5	63.6	67.2	74.1	63.3	65.4	71.7	67.1	71.5	72.3	50.4	73.5	76.3
WOMEN SHOULD GET JOB EQUALITY	94.0	91.9	94.6	96.3	92.0	90.6	98.8	94.4	95.4	93.5	95.1	96.0	97.5
ALL SHOULD GET COL OPPORTUNITY	70.8	79.1	67.2	64.1	79.3	77.9	65.4	67.6	67.5	65.0	68.1	65.3	59.3
CAN DO LITTLE TO CHANGE SOCIETY	38.7	39.3	38.0	39.1	39.4	38.6	39.4	38.3	39.7	36.8	34.7	39.4	37.6

**AMERICAN COUNCIL ON EDUCATION
OFFICE OF RESEARCH FALL 1971
WEIGHTED NATIONAL NORMS FOR FRESHMAN WOMEN**

	All Institutions	All 2-Year Colleges	All 4-Year Colleges	All Universities	2-Year Colleges		Technical Institutions	4-Year Colleges				Universities	
					Public	Private		Public	Private	Nonsect.	Prot-estant	Catholic	Public
AGREE STRONGLY OR SOMEWHAT													
COL REGULATE STUDENTS OFF CAMPUS	13.4	14.4	14.8	9.2	13.7	19.5	4.5	15.3	12.7	18.3	11.1	9.1	9.4
BENEFIT OF COLLEGE IS MONETARY	51.0	62.3	46.3	41.3	63.0	57.2	39.7	51.5	38.0	41.8	39.9	43.9	30.4
STUDENTS HELP EVALUATE FACULTY	75.8	71.7	76.7	80.7	71.8	71.5	83.9	76.8	77.4	75.8	75.4	80.4	81.7
ABOLISH COLLEGE GRADES	43.8	40.6	44.8	47.1	40.1	44.2	49.7	42.7	48.9	45.4	47.9	46.9	47.9
DE-EMPHASIZE ORGANIZED SPORTS	24.9	24.0	23.9	28.1	24.2	22.6	35.7	20.6	30.3	27.0	24.2	27.0	32.7
REGULATE STUDENT PUBLICATIONS	32.5	39.5	31.6	23.0	39.0	42.6	17.5	33.7	24.4	35.3	28.2	24.3	17.4
COLLEGE HAS RIGHT TO BAN SPEAKER	25.3	30.3	23.3	20.7	30.2	30.8	15.0	24.1	19.5	25.4	23.9	21.7	16.3
GIVE DISADVANTAGED PREF TRYMNT	38.5	41.3	38.1	34.5	41.0	43.5	38.9	38.2	38.7	40.1	32.8	34.8	33.5
COL TOO LAX ON STUDENT PROTEST	42.8	46.5	42.8	36.6	46.0	50.5	33.1	44.7	35.6	46.1	40.5	37.8	31.1
ADOPT OPEN ADMISSIONS AT PUB COL	36.7	46.0	32.3	29.6	47.3	36.9	31.1	31.0	34.5	31.5	38.1	30.1	27.5
USE SAME DEGREE STANDARD FOR ALL	76.2	76.2	75.3	77.9	76.7	72.2	73.7	75.5	76.1	74.6	74.9	77.8	78.3
CURRENT POLITICAL PREFERENCE													
FAR LEFT	1.9	1.2	2.2	2.3	1.2	1.6	3.9	1.6	4.5	2.1	1.6	2.0	3.2
LIBERAL	33.6	29.9	33.9	39.0	29.8	30.8	36.8	31.1	42.8	32.8	35.3	37.6	44.9
MIDDLE-OF-THE-ROAD	50.6	55.0	49.2	46.1	55.5	51.2	48.2	53.0	39.6	45.9	49.6	47.7	39.0
CONSERVATIVE	13.6	13.2	14.4	12.5	12.9	15.8	10.7	14.0	12.8	18.9	13.3	12.5	12.6
FAR RIGHT	.4	.7	.3	.2	.7	.6	.4	.3	.4	.3	.2	.2	.3
OBJECTIVES CONSIDERED TO BE ESSENTIAL OR VERY IMPORTANT													
ACHIEVE IN A PERFORMING ART	14.2	11.0	16.0	15.9	10.5	15.1	10.4	13.7	21.4	19.4	15.2	15.0	19.9
BE AN AUTHORITY IN MY FIELD	54.3	51.8	56.2	55.0	51.4	54.9	47.4	56.9	56.8	54.8	54.8	54.9	55.2
OBTAIN RECOGNITION FROM PEERS	31.6	30.1	32.7	31.8	29.7	33.2	32.4	32.4	34.2	31.7	33.6	31.3	33.7
INFLUENCE POLITICAL STRUCTURE	10.2	7.6	11.5	12.1	7.4	9.1	11.5	9.7	16.1	11.5	13.7	11.0	16.6
INFLUENCE SOCIAL VALUES	29.8	26.9	31.9	30.8	25.9	34.0	30.5	29.6	35.9	33.3	35.6	29.7	35.2
RAISE A FAMILY	64.7	66.7	65.3	60.3	66.1	71.6	59.3	66.2	61.3	65.3	68.1	61.0	57.2
HAVE ACTIVE SOCIAL LIFE	53.0	55.6	51.9	51.0	55.4	56.4	46.6	54.0	47.7	48.4	54.3	52.2	45.9
HAVE FRIENDS DIFFERENT FROM ME	64.4	62.6	65.2	65.9	62.2	65.7	65.6	64.3	65.7	65.0	70.5	65.5	67.6
BE AN EXPERT IN FINANCE	7.0	9.2	6.2	5.2	9.4	8.1	3.4	6.8	5.3	5.4	5.4	5.6	3.5
BE ADMINISTRATIVELY RESPONSIBLE	13.2	15.6	12.3	11.1	15.9	13.7	10.6	13.2	10.6	10.8	13.2	11.6	9.1
BE VERY WELL-OFF FINANCIALLY	28.2	32.3	26.2	25.3	32.5	31.2	21.0	28.1	24.1	23.9	23.8	26.2	21.7
HELP OTHERS IN DIFFICULTY	71.6	70.0	73.7	70.1	69.6	73.4	72.0	72.5	73.3	74.9	79.5	69.7	71.9
PARTICIPATE IN PEACE CORPS/VISTA	22.0	19.8	23.7	22.6	19.6	22.0	26.7	22.1	25.2	25.4	26.4	22.4	23.5
BECOME A COMMUNITY LEADER	10.0	8.2	11.5	10.1	7.8	11.5	6.7	11.5	11.6	12.9	10.1	9.6	12.3
CONTRIBUTE TO SCIENTIFIC THEORY	5.5	4.4	5.5	7.3	4.6	3.4	9.5	4.4	7.0	5.9	7.0	6.5	10.6
WRITE ORIGINAL WORKS	15.2	11.6	16.7	18.1	11.3	13.5	19.5	14.5	22.4	18.1	16.7	17.2	21.6
NEVER BE OBLIGATED TO PEOPLE	19.6	20.1	19.3	19.2	20.1	19.7	21.5	19.7	20.3	18.4	16.6	19.5	17.7
CREATE WORKS OF ART	20.3	17.5	20.9	24.0	16.9	21.6	31.8	18.6	26.4	21.6	21.1	24.1	23.3
KEEP UP WITH POLITICAL AFFAIRS	40.4	34.5	42.1	46.8	34.1	37.7	35.3	39.3	48.1	42.8	48.2	44.9	54.9
SUCCEED IN MY OWN BUSINESS	28.6	32.2	27.2	25.3	31.7	36.2	17.9	28.0	26.4	27.1	26.5	25.9	22.8
HELP CLEAN UP ENVIRONMENT	41.6	39.0	43.0	43.2	38.6	42.2	39.4	42.6	44.7	43.9	41.7	43.2	43.6
DEVELOP A PHILOSOPHY OF LIFE	73.5	67.1	76.2	78.8	66.7	69.9	79.0	73.6	80.2	78.0	80.9	77.9	82.3
PARTICIPATE IN COMMUNITY ACTION	28.5	24.9	31.1	29.5	24.6	27.5	23.5	30.0	33.5	32.0	33.5	28.6	33.4
MARRY WITHIN NEXT 5 YEARS	36.4	43.1	34.1	29.7	42.6	46.8	30.4	36.3	28.5	35.1	30.0	31.6	21.4

AMERICAN COUNCIL ON EDUCATION
OFFICE OF RESEARCH FALL 1971
WEIGHTED NATIONAL NORMS FOR FRESHMAN WOMEN

	All Insti- tutions	All 2-Year Colleges	All 4-Year Colleges	All Uni- versities	2-Year Colleges		4-Year Colleges					Universities	
					Public	Private	Technical Institutions	Public	Private Nonsect.	Prot- estant	Catholic	Public	Private
SELF RATINGS OF BETTER THAN 'AVERAGE' ON PERSONAL TRAITS													
ACADEMIC ABILITY	51.9	34.5	56.0	72.2	35.5	27.2	58.4	51.9	64.6	60.8	55.4	70.1	81.3
ATHLETIC ABILITY	24.3	22.5	24.6	26.5	22.1	25.8	17.8	24.3	26.4	24.6	24.4	26.4	27.0
ARTISTIC ABILITY	19.7	16.7	19.8	24.2	16.4	18.5	31.1	17.4	25.1	20.9	19.9	23.6	26.6
CHEERFULNESS	56.4	55.7	56.8	56.6	55.6	56.7	53.4	56.6	56.3	58.2	57.0	56.8	55.5
DEFENSIVENESS	26.9	25.7	27.1	28.3	25.8	25.1	26.5	27.2	26.9	26.5	27.8	28.6	27.1
DRIVE TO ACHIEVE	54.0	45.3	56.2	63.6	45.5	44.1	50.0	54.1	60.3	58.6	57.9	61.8	71.4
LEADERSHIP ABILITY	30.4	22.9	32.0	39.5	22.5	25.3	29.0	28.9	38.1	35.7	33.2	38.0	46.0
MATHEMATICAL ABILITY	25.5	17.7	26.4	36.3	18.3	12.8	32.4	24.7	29.8	27.2	27.6	34.2	45.2
MECHANICAL ABILITY	8.2	6.8	8.3	10.3	6.7	7.4	13.7	7.3	10.9	8.2	8.9	9.8	12.6
ORIGINALITY	33.4	26.1	35.5	41.3	25.5	30.6	41.4	32.1	43.9	37.5	35.7	39.8	47.9
POLITICAL CONSERVATISM	6.6	4.6	7.5	8.1	4.5	5.3	5.3	6.7	7.8	10.4	7.1	7.6	10.3
POLITICAL LIBERALISM	19.8	14.1	20.8	26.8	13.9	15.5	27.9	17.4	30.2	21.7	21.3	25.4	33.0
POPULARITY (GENERAL)	26.0	22.5	27.0	29.7	22.2	24.4	23.9	26.2	29.6	27.9	26.5	29.3	31.6
POPULARITY WITH OPPOSITE SEX	23.6	21.2	23.7	27.4	20.6	25.2	23.9	22.5	27.9	25.0	21.3	27.1	28.8
PUBLIC SPEAKING ABILITY	17.1	12.1	18.5	22.4	12.1	11.7	16.5	16.2	23.1	21.7	18.8	21.3	27.3
SELF-CONFIDENCE (INTELLECTUAL)	30.3	20.6	32.1	42.3	20.9	18.4	32.9	28.6	40.4	34.8	33.2	40.3	51.1
SELF-CONFIDENCE (SOCIAL)	24.5	21.5	24.8	28.6	21.1	24.5	21.1	23.5	29.5	25.2	24.4	27.9	31.6
SENSITIVITY TO CRITICISM	28.2	23.9	29.7	32.3	23.9	23.8	36.9	28.1	33.2	30.9	29.7	31.9	34.0
STUBBORNNESS	37.4	35.3	37.4	40.8	35.6	33.7	41.3	36.8	38.6	37.3	38.5	40.4	42.4
UNDERSTANDING OF OTHERS	67.3	63.9	68.9	69.7	63.4	67.6	70.1	66.9	73.3	70.0	70.1	69.0	72.9
WRITING ABILITY	29.3	21.9	31.0	37.8	21.9	21.4	29.5	28.0	38.7	34.3	29.6	35.9	45.9
STUDENTS ESTIMATE CHANCES ARE VERY GOOD THAT THEY WILL													
GET MARRIED WHILE IN COLLEGE	9.8	8.9	10.0	10.9	9.1	7.4	10.4	10.9	8.4	9.8	7.3	12.1	6.1
MARRY WITHIN A YEAR AFTER COL	22.2	20.8	23.2	22.7	20.4	23.5	22.1	23.3	20.9	25.8	22.7	23.2	20.3
VOTE IN 1972 PRES ELECTION	76.7	71.5	78.0	82.7	71.6	70.5	78.1	76.7	79.1	78.3	82.9	82.3	84.8
ENLIST IN ARMED SERV BEFORE GRAD	.3	.3	.3	.4	.3	.5	.0	.2	.3	.3	.8	.4	.6
CHANGE MAJOR FIELD	13.5	7.8	15.2	19.6	7.7	8.1	12.1	13.6	19.4	17.7	13.2	18.6	23.7
CHANGE CAREER CHOICE	14.1	8.5	15.5	20.4	8.4	9.1	10.1	13.2	20.9	19.0	14.2	19.2	25.2
FAIL ONE OR MORE COURSES	1.6	1.3	1.9	1.6	1.3	1.5	1.6	1.9	2.2	2.0	1.6	1.6	1.3
GRADUATE WITH HONORS	4.1	3.2	4.2	5.5	3.4	2.2	4.3	3.4	5.7	5.1	4.7	5.1	7.1
BE ELECTED TO A STUDENT OFFICE	1.1	1.2	1.1	.9	1.3	.8	1.2	.9	1.7	1.2	1.2	.7	1.7
JOIN SOC FRATERNITY OR SORORITY	15.9	13.2	17.9	16.8	12.2	20.2	19.1	16.3	19.0	21.1	19.8	15.4	22.8
BE ELECTED TO AN HONOR SOCIETY	3.4	2.2	3.7	4.9	2.1	2.5	2.8	2.9	4.8	4.9	4.3	4.6	6.3
MAKE AT LEAST A 'B' AVERAGE	25.2	21.9	24.6	31.9	22.4	17.8	28.3	20.3	30.4	30.3	28.7	30.7	36.6
NEED EXTRA TIME TO GET DEGREE	3.6	3.9	3.2	3.8	4.0	3.4	1.5	3.1	3.1	3.6	3.9	4.1	2.7
WORK AT OUTSIDE JOB	32.9	35.6	30.2	33.4	37.7	20.0	45.6	29.8	27.8	27.9	37.7	34.5	28.5
SEEK VOCATIONAL COUNSELING	12.4	9.2	13.9	15.1	9.2	9.3	14.3	12.9	15.0	14.6	16.2	15.0	15.3
SEEK PERSONAL COUNSELING	6.2	4.7	7.5	6.2	4.5	6.5	4.6	6.5	9.0	9.0	8.7	5.7	8.3
ENROLL IN HONORS COURSE	5.9	2.8	6.2	10.3	2.9	2.4	4.4	4.1	9.9	9.0	7.6	9.0	16.0
GET TUTORING HELP IN COURSES	6.0	4.3	7.3	6.3	3.8	7.5	5.2	6.7	9.6	7.0	8.0	6.1	6.9
AUTHOR A PUBLISHED ARTICLE	3.5	2.2	4.1	4.6	2.1	2.6	5.5	2.9	6.8	4.7	4.3	4.2	6.6
BE MORE SUCCESSFUL THAN MOST	5.2	5.1	5.1	5.7	5.2	4.2	5.0	4.9	5.7	5.3	4.8	5.7	5.5
DROP OUT TEMPORARILY	1.5	1.0	1.7	2.0	1.0	1.1	1.1	1.3	2.7	1.9	1.6	2.0	1.8
DROP OUT PERMANENTLY	1.0	.8	1.1	.9	.8	1.2	.4	1.0	1.4	1.3	1.0	.9	.9
TRANSFER TO ANOTHER COLLEGE	12.1	12.4	12.7	10.6	12.3	13.7	4.8	12.6	13.0	14.2	11.8	11.3	7.5
BE SATISFIED WITH MY COLLEGE	62.8	64.0	62.3	61.8	63.6	66.3	57.6	62.2	60.4	65.8	61.7	60.7	66.3

**AMERICAN COUNCIL ON EDUCATION
OFFICE OF RESEARCH FALL 1971
WEIGHTED NATIONAL NORMS FOR FRESHMAN WOMEN**

	All Insti- tutions	All 2-Year Colleges	All 4-Year Colleges	All Uni- versities	2-Year Colleges		4-Year Colleges				Universities		
					Public	Private	Technical Institutions	Public	Private Nonsect.	Prot- estant	Catholic	Public	Private
ACTIVITIES ENGAGED IN BY STUDENTS DURING THE PAST YEAR													
VOTED IN STUDENT ELECTION (3)	67.9	64.5	71.0	67.9	64.0	68.0	69.0	71.8	66.8	71.9	72.1	67.9	67.9
CAME LATE TO CLASS	51.1	47.8	52.9	52.9	46.5	56.7	50.7	50.8	59.7	55.1	49.6	51.9	57.4
PLAYED A MUSICAL INSTRUMENT	41.4	34.0	44.6	46.9	33.7	36.5	38.1	41.3	49.3	53.2	42.3	45.3	54.0
STUDIED IN THE LIBRARY (3)	36.2	33.8	37.6	37.4	33.7	34.6	28.0	36.4	38.6	40.3	39.9	36.5	41.2
CHECKED OUT A LIBRARY BOOK (3)	50.9	47.2	53.7	51.7	46.4	53.2	31.6	54.0	54.6	54.8	52.6	50.7	55.9
ARRANGED DATE FOR STUDENT OVERSLEPT AND MISSED A CLASS	40.3	41.7	39.6	39.4	40.2	52.4	30.1	41.1	36.2	37.9	41.4	39.3	39.7
READ ABOUT RIGHTS/RESPONSIBILITY	17.2	17.4	17.0	17.2	16.9	20.9	17.5	15.1	23.1	17.3	16.9	16.5	20.3
TYPED A HOMEWORK ASSIGNMENT (3)	72.2	69.0	74.5	73.1	67.8	77.4	69.2	74.7	75.3	74.3	72.8	72.2	76.7
DISCUSSED FUTURE WITH PARENTS (3)	30.0	29.4	29.6	31.8	30.1	24.2	25.5	29.4	30.1	29.3	31.3	31.9	31.5
WAS LATE WITH SCHOOL ASSIGNMENT	46.1	46.0	47.4	44.0	45.4	50.3	44.2	46.2	48.9	49.1	49.0	43.4	46.7
ARGUED WITH A TEACHER IN CLASS	60.2	60.0	61.1	58.6	59.1	66.9	59.3	60.0	64.8	62.6	58.8	58.8	57.9
ATTENDED A RELIGIOUS SERVICE	42.5	35.6	44.3	50.2	35.3	37.4	38.8	40.9	53.2	47.2	44.5	48.4	58.2
DEMONSTRATED FOR RACIAL CHANGE	89.0	87.5	90.8	88.3	87.1	90.3	86.6	91.7	85.0	91.6	94.7	88.6	87.0
DEMONSTRATED FOR MILITARY CHANGE	13.8	10.4	15.6	15.8	10.2	11.6	14.6	13.0	24.3	15.9	15.2	14.3	22.0
DEMONSTRATED FOR SCHOOL CHANGE	9.5	6.7	10.4	12.2	6.4	8.6	13.9	7.3	19.6	10.7	10.7	10.8	18.2
DID EXTRA READING FOR COURSE (3)	30.3	25.5	32.9	33.3	25.1	28.1	32.9	29.7	42.2	32.0	36.8	32.0	38.9
TOOK SLEEPING PILLS	17.2	13.5	18.4	20.7	13.4	14.1	17.0	16.5	23.7	19.1	19.2	19.4	26.2
TUTORED ANOTHER STUDENT	5.0	5.4	4.9	4.5	5.2	6.5	5.4	4.5	6.1	5.5	4.6	4.4	4.8
PLAYED CHESS	46.9	37.1	50.6	55.7	36.9	38.0	53.7	47.9	56.6	49.4	57.1	52.6	68.9
READ POETRY NOT REQUIRED	22.5	19.3	23.6	25.6	19.5	17.7	26.8	22.4	25.9	24.0	25.6	24.9	28.6
TOOK A TRANQUILIZING PILL	75.5	69.5	78.4	79.8	68.8	74.8	76.8	76.7	81.7	79.5	80.1	79.2	82.5
DISCUSSED RELIGION (3)	8.4	8.5	8.5	7.8	8.1	11.2	8.8	8.1	9.5	9.7	7.6	7.9	7.2
TOOK VITAMINS	32.1	26.5	35.1	35.4	25.9	30.7	33.9	31.6	38.6	41.5	38.1	34.6	38.6
VISITED ART GALLERY OR MUSEUM	63.7	62.9	63.7	65.1	62.5	66.2	60.5	61.4	68.1	66.9	64.3	65.1	65.2
PARTICIPATED IN H.S. POL. CMPG.	70.6	64.7	71.9	77.5	64.0	69.7	74.1	68.0	79.0	74.4	76.7	75.7	84.9
PARTICIPATED IN OTHER POL. CMPG.	37.8	32.1	41.0	41.1	31.0	39.8	33.2	39.8	41.9	41.9	46.8	39.9	46.1
MISSED SCHOOL DUE TO ILLNESS (3)	14.2	9.7	15.5	18.6	9.2	13.4	16.6	13.2	21.4	15.0	19.4	17.1	25.4
SMOKED CIGARETTES (3)	4.6	4.8	4.7	4.0	4.6	6.4	3.6	4.2	6.4	5.3	3.6	3.8	4.7
DISCUSSED POLITICS (3)	12.7	15.2	11.7	10.5	14.2	22.5	19.5	10.8	14.0	10.0	14.7	10.4	10.6
DRANK BEER	18.0	12.9	19.5	23.2	12.6	15.3	21.1	16.7	26.0	20.7	21.5	21.3	31.3
DISCUSSED SPORTS (3)	48.3	51.0	46.1	48.0	51.6	46.8	51.6	47.1	42.9	38.8	57.7	49.1	43.3
READ ABOUT CIVIL RIGHTS	27.6	26.4	28.9	27.0	25.9	30.2	19.3	30.9	24.0	29.4	26.5	27.9	23.4
ASKED TEACHER FOR ADVICE (3)	80.8	76.6	83.0	83.5	76.6	76.2	81.7	82.1	85.1	83.2	84.5	82.8	86.7
HAD VOCATIONAL COUNSELING	23.8	19.5	26.4	25.9	18.5	26.9	21.7	24.0	31.5	29.5	26.7	24.6	31.4
STAYED UP ALL NIGHT	48.5	50.0	49.5	44.1	49.8	51.6	52.4	51.9	40.2	47.0	55.7	45.8	37.1
	59.3	56.4	60.2	62.1	55.8	60.6	55.0	59.7	63.3	58.7	61.3	61.6	64.4

- (**)
THIS ITEM IS REPORTED FOR THE FIRST TIME IN 1971. ITEMS NOT INDICATED WITH '**' ARE REPEATED OR MODIFIED QUESTIONS FROM ONE OR MORE OF THE EARLIER SURVEYS.
- (1)
SINCE IT IS POSSIBLE THAT SOME STUDENTS MAY HAVE CHECKED MORE THAN ONE RESPONSE CATEGORY FOR THIS ITEM, THE PERCENTAGES MAY SUM TO MORE THAN 100.
- (2)
RECATORIZATION OF THIS ITEM FROM A LONGER LIST IS SHOWN IN APPENDIX C OF THE 1971 NAT'L NORMS REPORT.
- (3)
FREQUENTLY ONLY, ALL OTHER ITEMS FREQUENTLY PLUS OCCASIONALLY.

**AMERICAN COUNCIL ON EDUCATION
OFFICE OF RESEARCH FALL 1971
WEIGHTED NATIONAL NORMS FOR ALL FRESHMEN**

	All Institutions	All 2-Year Colleges	All 4-Year Colleges	All Universities	2-Year Colleges		4-Year Colleges				Universities		
					Public	Private	Technical Institutions	Public	Private Nonsect.	Prot-estant	Catholic	Public	Private
AGE BY DECEMBER 31, 1971													
16 OR YOUNGER	.1	.0	.1	.1	.0	.1	.1	.0	.2	.1	.1	.1	.3
17	3.4	2.0	3.9	4.8	1.9	3.3	3.8	2.8	6.8	4.3	4.0	3.9	8.4
18	74.1	65.9	78.5	81.0	65.5	69.7	79.1	78.5	78.0	76.6	81.9	81.0	80.9
19	16.0	20.4	13.9	11.7	20.5	19.8	13.9	14.3	12.3	15.4	11.5	12.4	9.2
20	2.1	3.6	1.3	.7	3.7	2.8	1.6	1.3	1.1	1.6	1.0	.8	.4
21	.7	1.3	.4	.3	1.3	.8	.4	.5	.3	.5	.3	.4	.2
22-25	2.3	4.1	1.3	.9	4.3	2.4	.7	1.8	.9	.9	.8	1.1	.4
26 OR OLDER	1.4	2.7	.7	.4	2.8	1.2	.4	.9	.4	.5	.4	.4	.2
FATHER'S EDUCATION													
GRAMMAR SCHOOL OR LESS	8.8	11.5	8.0	5.5	11.7	9.6	6.5	9.9	5.0	6.6	6.7	5.9	3.8
SOME HIGH SCHOOL	15.8	20.1	14.7	10.4	20.6	16.3	14.2	17.7	10.4	11.3	12.0	11.2	7.3
HIGH SCHOOL GRADUATE	30.9	35.1	29.5	25.9	35.7	29.3	30.4	33.7	21.8	24.2	29.6	27.7	19.4
SOME COLLEGE	16.9	15.9	17.0	18.3	15.7	17.3	19.1	16.9	16.0	16.4	18.3	18.8	16.6
COLLEGE DEGREE	18.4	13.4	19.6	25.1	12.7	19.2	20.4	15.5	25.9	24.2	21.5	24.3	28.1
POSTGRADUATE DEGREE	9.3	4.1	11.2	14.8	3.7	8.4	9.4	6.3	21.0	17.3	11.9	12.1	24.8
MOTHER'S EDUCATION													
GRAMMAR SCHOOL OR LESS	5.3	7.4	4.5	3.3	7.5	5.9	4.8	5.2	3.0	3.8	4.3	3.5	2.6
SOME HIGH SCHOOL	13.4	17.2	12.5	8.6	17.6	14.0	12.6	15.1	8.7	9.2	10.2	9.2	6.0
HIGH SCHOOL GRADUATE	45.0	48.7	43.4	41.2	49.4	42.5	46.9	47.2	34.5	36.5	47.5	43.4	33.0
SOME COLLEGE	17.9	14.7	18.8	22.1	14.3	18.3	18.3	17.7	20.8	20.8	18.2	21.9	23.1
COLLEGE DEGREE	15.2	10.5	16.9	20.6	9.8	16.7	14.6	12.5	24.7	23.9	16.8	18.7	27.4
POSTGRADUATE DEGREE	3.1	1.5	4.0	4.3	1.4	2.5	2.7	2.3	8.3	5.7	3.1	3.2	8.0
RACIAL BACKGROUND (1)													
WHITE/CAUCASIAN	91.4	91.8	89.0	94.5	91.5	95.6	93.3	88.6	85.9	88.8	93.7	94.9	92.9
BLACK/NEGRO/AFRO-AMERICAN	6.3	4.7	9.4	3.8	5.0	2.3	4.4	10.3	12.3	9.9	3.1	3.6	4.5
AMERICAN INDIAN	.9	1.0	.9	1.0	1.0	1.0	.6	.8	1.1	.9	.6	1.1	.6
ORIENTAL	.5	.3	.4	.8	.3	.4	1.1	.2	.8	.4	.6	.6	1.5
MEXICAN-AMERICAN/CHICANO	1.1	2.2	.3	.4	2.4	.3	.4	.1	.3	.3	1.7	.3	.5
PUERTO RICAN-AMERICAN	.2	.1	.3	.2	.1	.2	.3	.4	.3	.1	.4	.1	.5
OTHER	1.2	1.3	1.0	1.1	1.3	1.9	1.3	.8	1.3	.9	1.5	1.1	.9
ESTIMATED PARENTAL INCOME													
LESS THAN \$4,000	5.3	7.0	5.1	2.9	7.0	6.6	2.1	6.2	4.3	5.1	3.5	3.0	2.2
\$4,000 - \$5,999	6.7	7.9	6.9	4.4	8.1	6.8	4.3	8.3	5.3	6.8	5.1	4.6	3.6
\$6,000 - \$7,999	9.8	11.9	9.3	6.9	12.1	9.9	7.4	10.9	7.1	8.7	7.6	7.5	4.8
\$8,000 - \$9,999	12.6	14.5	11.8	10.5	14.7	12.0	12.5	13.3	8.7	10.2	10.9	11.3	7.5
\$10,000 - \$12,499	18.1	19.7	17.0	17.2	20.1	15.6	19.0	18.4	13.0	15.3	17.7	18.4	12.9
\$12,500 - \$14,999	14.2	13.8	14.1	14.8	13.9	12.7	18.0	14.5	11.7	12.8	15.0	15.7	11.4
\$15,000 - \$19,999	14.3	12.5	14.6	16.8	12.5	13.1	18.8	13.8	14.7	14.2	15.5	17.1	15.9
\$20,000 - \$24,999	8.1	6.1	8.5	10.8	5.9	7.7	9.6	7.2	10.8	9.4	9.3	10.3	12.6
\$25,000 - \$29,999	3.8	2.5	4.2	5.5	2.3	4.7	4.2	3.0	6.5	5.1	4.8	4.8	7.8
\$30,000 - \$34,999	2.4	1.6	2.8	3.3	1.4	3.7	1.6	1.8	4.9	4.0	3.5	2.7	5.4
\$35,000 - \$39,999	1.3	.7	1.6	1.8	.6	2.1	1.0	.9	3.2	2.2	2.0	1.3	3.8
\$40,000 OR MORE	3.4	1.7	4.0	5.1	1.3	5.2	1.6	1.8	9.7	6.1	5.1	3.2	12.2

AMERICAN COUNCIL ON EDUCATION
OFFICE OF RESEARCH FALL 1971
WEIGHTED NATIONAL NORMS FOR ALL FRESHMEN

	All Insti- tutions	All 2-Year Colleges	All 4-Year Colleges	All Uni- versities	2-Year Colleges		4-Year Colleges					Universities	
					Public	Private	Technical Institutions	Public	Private Nonsect.	Prot- estant	Catholic	Public	Private
RELIGION REARED													
PROTESTANT	49.8	46.4	52.5	51.2	45.8	52.6	46.7	55.5	49.7	73.6	8.9	53.6	42.5
ROMAN CATHOLIC	34.8	38.3	32.8	32.4	40.0	21.7	45.0	30.0	25.3	12.2	88.0	32.2	33.2
JEWISH	3.6	1.9	3.1	7.4	1.8	2.6	1.8	1.6	10.9	1.7	.5	4.7	17.0
OTHER	9.4	11.1	9.5	6.5	10.0	20.8	4.3	11.2	10.6	10.3	1.8	7.0	4.6
NONE	2.3	2.4	2.0	2.6	2.4	2.3	2.2	1.7	3.4	2.1	.8	2.5	2.8
RELIGIOUS PREFERENCE													
PROTESTANT	41.5	38.8	44.7	40.9	38.0	46.4	41.7	48.3	36.9	64.2	7.0	43.4	31.4
ROMAN CATHOLIC	29.5	33.6	27.6	25.6	35.1	19.0	38.8	25.5	18.7	9.5	78.1	25.4	26.3
JEWISH	2.8	1.5	2.3	5.8	1.4	2.2	1.5	1.2	7.9	1.4	.4	3.7	13.7
OTHER	11.7	13.3	11.8	9.1	12.3	22.8	5.8	13.0	14.1	12.7	4.6	9.6	7.3
NONE	14.4	12.8	13.6	18.6	13.1	9.6	12.2	11.9	22.3	12.3	10.0	17.9	21.3
FATHER'S OCCUPATION (2)													
ARTIST (INCL PERFORMER)	.8	.7	.8	.9	.7	.8	.7	.6	1.3	.9	.8	.9	1.2
BUSINESSMAN	29.7	26.7	30.7	33.3	25.9	33.7	28.6	27.1	37.3	32.8	37.2	31.5	39.8
CLERGYMAN	.9	.6	1.3	.6	.4	2.3	.4	.7	1.6	4.0	.1	.5	.9
COLLEGE TEACHER	.8	.4	.9	1.2	.4	.4	.7	.5	1.6	1.7	.6	1.0	2.0
DOCTOR (M.D. OR D.D.S.)	1.9	.7	2.2	3.2	.6	1.9	.8	.9	4.8	3.8	3.3	2.1	7.1
EDUCATOR (SECONDARY)	2.2	1.7	2.8	2.2	1.7	1.6	2.8	2.8	2.7	3.1	2.0	2.3	1.9
ELEMENTARY TEACHER	.3	.3	.4	.3	.2	.5	.5	.4	.4	.5	.3	.3	.3
ENGINEER	7.5	6.5	7.0	10.1	6.5	6.4	9.4	6.5	7.5	6.8	6.7	10.3	9.3
FARMER OR FORESTER	6.8	8.6	5.3	6.0	9.0	5.6	2.1	7.0	2.3	6.1	2.8	7.2	1.6
HEALTH PROFESSIONAL (NON-M.D.)	1.2	1.1	1.2	1.5	1.1	1.0	1.2	1.1	1.5	1.1	1.2	1.5	1.6
LAWYER	1.2	.5	1.4	2.0	.5	1.4	.9	.6	3.0	1.7	2.5	1.4	4.1
MILITARY CAREER	2.0	1.5	2.5	1.9	1.4	2.1	7.8	2.4	1.2	1.6	1.1	2.0	1.4
RESEARCH SCIENTIST	.6	.2	.6	1.2	.2	.3	.5	.4	1.0	.8	.6	1.1	1.6
SKILLED WORKER	12.3	14.9	11.3	9.8	15.3	10.8	14.5	12.6	8.4	8.5	11.2	10.5	7.4
SEMI-SKILLED WORKER	7.6	9.3	7.1	5.6	9.6	6.2	6.9	8.7	5.0	5.3	6.1	6.0	4.1
UNSKILLED WORKER	3.8	4.6	3.8	2.6	4.8	2.7	3.6	4.6	2.6	2.9	3.2	2.8	1.7
UNEMPLOYED	1.4	1.7	1.3	1.0	1.7	1.8	.8	1.6	1.3	1.2	1.1	1.0	.7
OTHER	19.0	20.0	19.5	16.6	20.0	20.4	17.8	21.5	16.7	17.1	19.3	17.5	13.3
VETERAN													
NO	97.2	95.1	98.2	99.0	94.9	97.5	97.1	97.5	99.1	99.1	99.4	98.8	99.7
YES, SERVED IN SOUTHEAST ASIA	1.5	2.6	.8	.5	2.8	1.3	.3	1.2	.4	.4	.4	.6	.2
YES, DID NOT SERVE IN SE ASIA	1.4	2.2	1.0	.5	2.3	1.2	2.7	1.3	.4	.5	.2	.6	.2
MARITAL STATUS **													
PRESENTLY MARRIED	2.8	4.7	1.8	1.2	4.8	2.8	.8	2.4	1.1	1.5	1.2	1.4	.6
NOT MARRIED	97.2	95.3	98.2	98.8	95.2	97.2	99.2	97.6	98.9	98.5	98.8	98.6	99.4
DISTANCE FROM HOME TO COLLEGE													
5 MILES OR LESS	11.4	18.3	7.1	6.5	19.3	9.3	4.4	7.5	5.5	6.3	11.9	6.7	5.6
6-10 MILES	11.8	18.1	6.4	9.8	19.3	6.9	7.7	6.0	6.5	3.4	13.0	10.3	8.1
11-50 MILES	26.8	36.4	21.1	19.7	37.6	24.9	18.2	26.1	14.1	13.1	23.7	20.3	17.5
51-100 MILES	14.6	12.0	16.7	15.8	11.4	17.1	9.4	19.8	11.8	17.8	13.6	18.0	7.6
101-500 MILES	27.7	13.3	35.2	40.2	11.4	30.4	21.8	36.1	39.8	39.0	27.4	40.5	38.9
MORE THAN 500 MILES	7.7	2.1	13.5	8.1	1.1	11.4	38.5	4.5	22.4	20.5	10.4	4.2	22.3

AMERICAN COUNCIL ON EDUCATION
OFFICE OF RESEARCH FALL 1971
WEIGHTED NATIONAL NORMS FOR ALL FRESHMEN

	All Insti- tutions	All 2-Year Colleges	All 4-Year Colleges	All Uni- versities	2-Year Colleges		4-Year Colleges					Universities	
					Public	Private	Technical Institutions	Public	Private Nonsect.	Prot- estant	Catholic	Public	Private
AVERAGE GRADE IN HIGH SCHOOL													
A OR A+	5.7	1.9	6.1	11.6	1.9	2.0	12.5	3.7	9.0	7.3	6.0	8.5	22.7
A-	9.3	4.2	10.6	15.7	4.2	4.0	18.7	7.7	14.1	12.0	10.2	14.2	21.3
B+	17.4	11.1	20.4	23.4	11.3	9.1	27.4	18.5	22.4	19.9	21.1	23.6	22.8
B	25.0	24.4	26.3	24.0	24.9	20.2	24.3	27.2	25.1	24.6	28.8	25.6	17.8
B-	16.4	19.0	15.7	13.2	19.1	17.7	10.5	17.5	13.3	15.0	16.1	14.4	8.7
C+	15.4	22.2	12.7	8.4	22.0	24.1	4.8	15.4	9.8	12.5	11.3	9.4	5.0
C	10.1	16.1	7.7	3.6	15.5	21.4	1.7	9.5	5.9	8.1	6.2	4.1	1.6
D	.6	1.1	.4	.1	1.1	1.5	.1	.4	.4	.5	.3	.1	.1
RANK IN HIGH SCHOOL CLASS													
TOP QUARTER	41.8	21.2	49.1	64.3	21.3	20.2	72.1	43.9	54.3	50.8	42.7	61.4	74.7
SECOND QUARTER	31.3	33.7	32.0	26.0	33.9	32.4	21.8	35.4	28.0	30.0	33.7	28.0	18.6
THIRD QUARTER	23.0	37.8	16.5	8.6	37.6	40.4	5.2	18.4	14.9	16.4	20.3	9.2	6.0
FOURTH QUARTER	4.0	7.2	2.4	1.2	7.2	7.0	.8	2.3	2.8	2.8	3.4	1.3	.7
SECONDARY SCHOOL ACHIEVEMENTS													
PRESIDENT STUDENT ORGANIZATION	18.4	12.9	21.5	22.8	12.5	16.2	27.3	18.7	23.6	25.1	20.9	21.4	27.9
HIGH RATING STATE MUSIC CONTEST	10.1	8.1	11.1	12.2	8.0	8.2	7.3	11.2	10.2	16.0	7.0	12.6	10.5
STATE/REGIONAL SPEECH CONTEST	4.5	2.9	5.3	6.1	2.9	3.2	5.4	4.8	5.6	5.7	6.4	5.8	7.4
MAJOR PART IN A PLAY	14.9	12.0	16.9	16.4	11.9	13.5	13.7	16.0	18.5	20.3	15.9	16.3	17.0
VARSITY LETTER (SPORTS)	32.8	31.3	34.7	32.2	31.3	31.1	54.4	32.4	33.5	35.2	30.1	31.9	32.9
AWARD IN ART COMPETITION	5.5	5.4	5.6	5.7	5.3	6.3	4.4	5.2	6.9	6.1	5.8	5.8	5.2
EDITOR OF SCHOOL PAPER	11.5	8.3	13.3	14.1	8.1	10.3	9.6	12.2	16.4	14.3	15.0	12.8	18.8
ORIGINAL WRITING PUBLISHED	15.1	10.4	17.5	19.1	10.2	13.1	14.5	15.0	22.7	20.1	19.6	17.4	25.2
NSF SUMMER PROGRAM	.7	.3	.8	1.4	.3	.2	1.8	.5	1.1	.7	.6	.9	3.3
STATE/REGIONAL SCIENCE PROGRAM	1.9	1.4	2.0	2.8	1.3	1.5	3.1	1.8	2.1	2.3	1.8	2.4	4.2
SCHOLASTIC HONOR SOCIETY	24.5	10.6	29.5	40.3	10.6	11.0	47.6	24.5	33.5	32.1	27.7	37.4	51.1
NATIONAL MERIT RECOGNITION	7.7	3.2	8.9	13.6	3.3	2.2	13.9	5.4	17.5	8.5	8.0	9.9	27.2
YEAR FINISH SECONDARY SCHOOL **													
GRADUATED IN 1971	90.4	84.4	93.6	95.5	83.8	89.1	92.5	93.1	94.6	93.8	95.5	95.1	96.9
DID NOT GRADUATE IN 1971	9.6	15.6	6.4	4.5	16.2	10.9	7.5	6.9	5.4	6.2	4.5	4.9	3.1
HIGHEST DEGREE PLANNED													
NONE	6.5	10.9	4.2	3.0	11.3	7.4	3.0	4.4	4.0	4.4	4.3	3.2	2.3
ASSOCIATE (OR EQUIVALENT)	10.2	23.6	1.8	1.2	24.5	14.9	.1	2.6	.8	1.9	.8	1.5	.3
BACHELOR'S (B.A., B.S.)	37.5	33.3	40.7	39.2	32.6	39.8	27.9	46.4	33.4	38.1	39.3	43.2	24.4
MASTER'S (M.A., M.S.)	25.9	17.7	32.4	29.2	17.2	22.4	42.7	32.0	30.9	29.6	31.8	29.5	28.3
PH.D. OR ED.D.	7.6	3.6	9.6	11.3	3.4	5.1	19.0	6.5	13.6	10.3	8.5	9.3	18.6
M.D., D.O., D.D.S., OR D.V.M.	4.9	2.7	4.7	9.0	2.7	3.1	3.6	2.8	7.8	6.6	6.6	7.2	15.7
LL.B. OR J.D. (LAW)	3.6	1.8	4.3	5.4	1.8	2.3	3.0	3.0	6.9	5.3	6.1	4.3	9.2
B.D. (DIVINITY)	.3	.2	.4	.1	.2	.7	.2	.1	.5	1.5	.3	.1	.1
OTHER	3.5	6.1	2.0	1.5	6.3	4.2	.4	2.1	2.0	2.3	2.3	1.6	1.1
CONCERN ABOUT FINANCING COLLEGE													
NO CONCERN	33.9	37.0	32.5	31.1	36.8	39.4	60.7	28.3	34.3	32.1	26.4	29.8	36.0
SOME CONCERN	55.6	54.2	55.8	57.7	54.5	51.5	35.2	59.1	53.9	55.7	60.5	58.5	54.6
MAJOR CONCERN	10.4	8.7	11.7	11.2	8.7	9.0	4.1	12.6	11.9	12.2	13.1	11.7	9.4

AMERICAN COUNCIL ON EDUCATION
OFFICE OF RESEARCH FALL 1971
WEIGHTED NATIONAL NORMS FOR ALL FRESHMEN

	All Insti- tutions	All 2-Year Colleges	All 4-Year Colleges	All Uni- versities	2-Year Colleges		4-Year Colleges					Universities		
					Public	Private	Technical Institutions	Public	Private Nonsect.	Prot- estant	Catholic	Public	Private	
MAJOR SOURCES OF FINANCIAL SUPPORT FOR COLLEGE (1)														
PART-TIME OR SUMMER WORK	29.0	33.9	24.4	28.3	35.5	19.4	19.5	27.6	18.7	20.7	27.9	30.8	18.8	
SAVINGS FROM FULL-TIME EMPLOY	9.4	12.2	7.7	7.5	12.7	6.7	17.2	7.7	5.2	5.8	6.9	8.2	4.7	
PARENTAL OR FAMILY AID OR GIFTS	54.5	45.3	57.4	65.6	43.7	60.5	23.8	55.9	69.7	66.7	58.6	63.6	72.8	
PARENT'S MILITARY SERVICE	1.9	2.2	1.8	1.5	2.2	2.2	1.2	2.1	1.6	1.6	1.6	1.7	.9	
PERSONAL MILITARY SERVICE	2.5	4.1	1.8	1.0	4.3	2.2	5.6	2.0	.8	.8	.6	1.1	.3	
SCHOLARSHIPS AND GRANTS	19.3	13.7	24.5	20.8	13.0	20.1	26.3	20.6	26.8	30.3	29.8	17.3	33.5	
LOANS-NDEA/GOV'T INSURED/COLLEGE	14.7	12.3	17.7	14.2	11.7	17.7	4.2	15.4	21.1	24.1	25.5	12.6	20.1	
OTHER REPAYABLE LOANS	6.2	5.9	7.7	4.4	5.7	8.0	3.6	7.8	8.5	8.3	9.1	4.3	4.8	
PROBABLE MAJOR FIELD OF STUDY (2)														
AGRICULTURE (INCL FORESTRY)	3.2	5.2	1.3	3.0	5.6	1.8	.3	1.7	1.5	.8	.3	3.8	.1	
BIOLOGICAL SCIENCES	3.6	2.3	4.2	4.8	2.4	1.9	4.9	3.7	5.0	4.7	3.9	4.7	5.2	
BUSINESS	16.4	25.3	11.9	8.7	25.8	20.2	8.5	13.6	9.6	10.5	12.6	9.3	6.7	
EDUCATION	9.9	8.3	13.5	6.5	7.8	12.8	1.2	19.2	7.2	11.3	9.4	7.4	3.5	
ENGINEERING	7.2	8.2	5.4	8.5	8.4	6.6	37.1	2.6	2.2	2.0	2.2	8.1	10.0	
ENGLISH	2.2	1.3	2.9	2.5	1.3	1.8	.9	2.6	3.8	3.3	4.3	2.4	3.1	
HEALTH PROFESSIONS (NON-M.D.)	8.8	10.6	7.6	7.9	10.8	7.9	1.5	8.7	6.6	6.2	11.8	8.2	7.0	
HISTORY, POLITICAL SCIENCE	4.2	2.4	5.9	4.5	2.3	3.5	5.8	5.2	7.6	5.7	7.2	3.8	6.8	
HUMANITIES (OTHER)	3.1	1.9	4.2	3.3	1.7	3.7	1.9	2.8	6.0	7.3	4.8	3.0	4.3	
FINE ARTS	9.0	8.1	9.2	10.1	7.6	12.4	3.9	8.8	11.8	11.7	7.4	10.7	7.9	
MATHEMATICS OR STATISTICS	2.7	1.3	3.6	3.8	1.3	1.2	4.4	3.4	3.3	3.5	4.2	3.5	5.0	
PHYSICAL SCIENCES	2.0	1.0	2.3	3.3	1.0	.6	6.6	1.7	2.3	2.2	1.8	2.9	4.7	
PRE-PROFESSIONAL	8.5	5.6	8.4	13.4	5.5	6.2	5.7	6.2	12.3	11.3	11.5	11.3	21.3	
SOCIAL SCIENCES	3.6	6.2	10.8	9.2	5.9	9.7	4.4	9.6	14.2	13.1	13.0	9.2	9.4	
OTHER FIELDS (TECHNICAL)	5.1	7.5	3.4	3.9	7.9	4.0	3.7	4.0	2.9	2.2	2.4	4.3	2.4	
OTHER FIELDS (NONTECHNICAL)	3.1	2.5	3.2	3.9	2.4	3.4	8.2	3.4	1.4	2.0	1.9	4.8	.5	
UNDECIDED	2.3	2.2	2.3	2.4	2.2	2.5	1.0	2.6	2.4	2.4	1.5	2.6	2.0	
PROBABLE CAREER OCCUPATION (2)														
ARTIST (INCL PERFORMER)	6.0	4.7	6.6	7.1	4.4	7.9	2.3	6.0	9.6	7.8	6.2	7.4	6.0	
BUSINESSMAN	10.7	14.5	8.9	7.4	14.9	10.5	7.7	9.3	8.1	8.1	11.2	7.7	6.6	
CLERGYMAN	.6	.4	1.1	.3	.2	2.5	.2	.3	1.3	3.7	1.5	.2	.6	
COLLEGE TEACHER	.7	.4	.9	.9	.3	.8	.6	.7	1.3	1.2	.7	.7	1.6	
DOCTOR (M.D. OR D.D.S.)	4.4	2.0	4.4	8.2	1.9	2.8	2.8	2.6	7.4	6.5	6.9	6.0	16.3	
EDUCATOR (SECONDARY)	8.6	6.1	12.2	7.0	6.0	7.7	2.5	16.4	7.7	10.7	9.4	7.7	4.5	
ELEMENTARY TEACHER	6.8	5.5	9.7	4.3	5.0	10.1	1.2	13.4	5.0	8.3	9.2	4.9	2.3	
ENGINEER	5.3	5.1	4.1	7.7	5.1	4.8	27.4	1.8	1.8	1.7	2.0	7.4	8.8	
FARMER OR FORESTER	2.9	4.2	1.6	2.8	4.5	1.8	.6	1.9	1.8	1.2	.6	3.4	.4	
HEALTH PROFESSIONAL (NON-M.D.)	6.1	6.1	5.4	7.3	6.1	5.4	1.2	6.2	6.4	4.9	5.0	8.4	3.3	
LAWYER	4.3	2.3	5.1	6.3	2.2	2.7	2.9	3.8	7.8	6.3	7.2	5.2	10.0	
NURSE	4.1	5.5	3.3	3.2	5.7	3.6	.8	3.7	1.5	2.7	7.8	3.0	4.0	
RESEARCH SCIENTIST	2.5	1.2	2.6	4.4	1.2	1.3	5.1	1.8	3.5	2.6	2.5	3.9	6.3	
OTHER	23.8	30.6	20.3	18.1	31.0	26.2	36.7	19.1	18.5	18.1	17.4	19.4	13.8	
UNDECIDED	13.2	11.4	13.9	14.9	11.3	11.9	7.9	12.9	18.5	16.2	12.6	14.7	15.6	

**AMERICAN COUNCIL ON EDUCATION
OFFICE OF RESEARCH FALL 1971
WEIGHTED NATIONAL NORMS FOR ALL FRESHMEN**

	All Insti- tutions	All 2-Year Colleges	All 4-Year Colleges	All Uni- versities	2-Year Colleges		Technical Institutions	4-Year Colleges			Universities		
					Public	Private		Public	Private Nonsect.	Prot- estant	Catholic	Public	Private
REASONS NOTED AS VERY IMPORTANT IN DECIDING TO GO TO COLLEGE **													
PARENTS WANTED ME TO GO	22.9	22.7	24.1	21.3	21.9	30.3	20.7	23.3	24.9	28.1	23.2	21.2	21.6
CONTRIBUTE MORE TO MY COMMUNITY	18.7	16.1	21.1	19.1	15.8	19.1	18.1	19.6	23.3	22.8	25.4	17.8	24.0
GET A BETTER JOB	73.8	79.9	70.5	68.7	80.3	76.8	73.6	75.9	61.1	64.3	66.1	70.6	61.7
GAIN A GENERAL EDUCATION	59.5	54.3	62.7	62.9	53.6	60.6	59.1	60.3	69.3	64.5	64.6	60.9	70.2
IMPROVE READING/STUDY SKILLS	22.2	24.2	22.5	18.2	23.7	29.4	17.4	23.5	22.1	23.2	21.3	18.5	17.0
NOTHING BETTER TO DO	2.2	2.2	2.1	2.5	2.2	1.7	1.6	2.1	2.6	2.3	1.6	2.4	2.5
BECOME MORE CULTURED	28.9	27.4	31.1	27.7	26.7	34.0	25.9	30.5	32.5	33.4	33.3	27.1	29.8
MAKE MORE MONEY	49.9	58.6	44.8	43.6	59.3	52.2	47.2	50.2	36.6	38.8	38.3	45.7	35.7
LEARN MORE ABOUT MY INTERESTS	68.8	66.1	69.5	72.4	66.2	65.1	67.3	67.8	75.5	70.1	68.9	71.1	76.9
MEET NEW/INTERESTING PEOPLE	45.1	40.3	48.0	48.4	39.6	47.2	33.9	47.5	52.7	49.7	52.3	47.4	51.8
PREPARE FOR GRAD OR PROF SCHOOL	34.5	33.8	34.1	36.3	33.1	40.2	36.9	29.8	39.3	38.5	37.0	32.8	49.1
REASONS NOTED AS VERY IMPORTANT IN SELECTING THIS COLLEGE **													
RELATIVES WANTED ME TO GO	7.8	8.3	8.0	6.5	8.0	11.0	9.0	7.6	7.0	9.6	7.8	6.8	5.7
COLLEGE HAS A GOOD REPUTATION	36.1	28.7	39.6	43.2	26.9	46.0	59.8	30.9	45.8	47.5	42.5	39.0	58.2
MOST FRIENDS GOING TO THIS COL	4.5	6.1	3.4	3.8	6.2	4.4	7	5.2	1.5	2.1	1.7	4.7	8
LOW TUITION	18.8	25.8	12.7	16.6	28.0	4.9	22.6	18.2	4.7	2.9	5.0	20.6	2.0
ADVICE OF SOMEONE WHO ATTENDED	15.7	15.9	16.4	14.2	15.3	22.0	12.1	16.0	15.4	19.9	18.2	14.7	12.3
SPECIAL EDUC PROGRAM OFFERED	32.6	31.9	33.2	32.6	31.9	31.9	56.4	28.0	38.8	31.8	31.8	30.0	42.0
NOT ACCEPTED ANYWHERE ELSE	3.1	3.8	2.8	2.2	3.8	4.1	1.4	2.8	3.4	2.8	3.1	2.3	2.0
ADVICE OF GUIDANCE COUNSELOR	7.2	9.5	6.5	4.2	9.2	12.8	5.2	5.9	7.6	6.9	8.1	3.8	5.9
WANTED TO LIVE AT HOME	12.2	20.0	6.8	7.5	21.2	8.8	6.1	8.1	4.8	3.6	9.6	8.5	3.9
NEED FOR SPECIAL HELP IN (1) **													
ENGLISH	16.3	18.7	15.4	13.9	18.5	20.1	17.9	16.2	14.1	14.6	12.6	14.9	10.0
READING	10.6	11.3	9.6	11.0	11.2	12.1	12.1	8.7	10.1	11.0	9.2	11.7	8.6
MATHEMATICS	36.0	38.1	37.7	29.3	37.3	45.9	24.2	41.1	34.8	37.0	38.6	31.0	23.3
SOCIAL STUDIES	3.8	4.3	3.8	2.8	4.4	4.2	4.1	3.9	3.4	3.6	3.6	2.8	2.5
SCIENCE	21.0	18.9	23.9	20.0	18.4	23.5	18.3	24.7	22.6	24.1	26.6	20.9	16.9
FOREIGN LANGUAGE	20.8	17.3	24.9	20.2	16.3	26.3	27.3	21.8	25.7	30.4	28.1	20.8	18.3
AGREE STRONGLY OR SOMEWHAT													
GOV'T NOT CONTROLLING POLLUTION	90.5	88.9	91.1	92.4	88.9	89.2	90.2	90.8	92.6	91.0	91.3	92.0	93.9
GOV'T NOT PROTECTING CONSUMER	76.6	75.3	76.7	78.8	75.2	76.2	69.7	76.1	81.3	77.2	77.4	78.1	81.5
GOV'T NOT DESEGREGATING QUICKLY	51.7	52.1	51.1	51.9	52.7	46.7	42.3	50.2	58.8	49.5	53.5	50.8	56.1
TOO MANY RIGHTS FOR CRIMINALS	48.1	51.3	46.3	45.5	51.5	49.2	56.9	47.6	38.8	46.1	42.6	47.2	39.2
SHOULD ABOLISH DEATH PENALTY	57.6	53.3	60.0	61.1	53.1	55.4	50.2	59.3	65.1	58.6	66.4	59.6	66.6
WOMEN'S ACTIVITIES BEST IN HOME	42.2	48.2	40.8	34.0	47.9	51.7	46.8	41.9	33.9	41.5	40.3	35.6	28.3
BARELY COMMUNICATE WITH PARENTS	18.6	20.4	17.1	17.9	20.7	17.6	13.9	18.7	15.9	15.3	16.3	18.3	16.6
SHOULD LEGALIZE MARIJUANA	38.7	35.5	37.8	45.5	35.8	32.9	34.3	35.3	48.3	35.9	39.3	44.1	50.5
SHOULD DISCOURAGE LARGE FAMILIES	68.5	64.4	68.4	75.6	64.3	65.5	70.6	68.2	72.6	72.1	52.6	75.1	77.5
WOMEN SHOULD GET JOB EQUALITY	87.8	84.9	88.9	91.1	84.9	84.9	87.2	88.5	91.2	88.5	89.5	90.6	93.1
ALL SHOULD GET COL OPPORTUNITY	68.5	77.5	64.3	60.0	77.6	75.8	45.9	67.6	64.4	62.5	65.9	61.6	54.2
CAN DO LITTLE TO CHANGE SOCIETY	42.9	44.5	41.3	42.8	44.9	40.9	40.8	41.6	42.8	40.2	38.9	43.3	41.0

AMERICAN COUNCIL ON EDUCATION
OFFICE OF RESEARCH FALL 1971
WEIGHTED NATIONAL NORMS FOR ALL FRESHMEN

	All Insti- tutions	All 2-Year Colleges	All 4-Year Colleges	All Uni- versities	2-Year Colleges		Technical Institutions	4-Year Colleges			Universities		
					Public	Private		Public	Private Nonsect.	Prot- estant	Catholic	Public	Private
AGREE STRONGLY OR SOMEWHAT													
COL REGULATE STUDENTS OFF CAMPUS	13.8	15.0	14.8	10.1	14.3	21.1	13.4	15.0	12.6	18.9	11.9	10.0	10.3
BENEFIT OF COLLEGE IS MONETARY	59.2	69.2	54.1	50.5	69.7	64.2	58.4	59.0	45.4	48.7	47.8	53.5	39.7
STUDENTS HELP EVALUATE FACULTY	76.0	73.3	76.5	79.8	73.4	72.7	74.9	77.2	77.0	75.3	74.9	79.7	80.3
AROLISH COLLEGE GRADES	42.6	40.6	43.5	44.7	40.6	40.9	33.7	43.4	46.4	44.5	47.1	45.0	43.5
DE-EMPHASIZE ORGANIZED SPORTS	26.0	25.5	24.7	28.9	25.7	23.6	24.5	21.7	30.6	27.9	24.6	27.7	33.5
REGULATE STUDENT PUBLICATIONS	32.5	39.2	31.3	23.2	38.5	45.5	29.2	33.6	23.8	34.5	28.0	24.6	18.2
COLLEGE HAS RIGHT TO BAN SPEAKER	27.8	32.1	26.0	23.1	31.8	35.1	35.0	25.9	20.7	27.3	25.1	24.2	19.2
GIVE DISADVANTAGED PREF TRTMT	40.1	44.0	39.2	34.7	43.7	46.9	31.8	40.5	39.9	41.1	34.5	35.1	33.4
COL TOO LAX ON STUDENT PROTEST	46.5	50.8	46.0	39.9	50.5	53.8	60.0	46.4	37.7	47.5	42.4	41.3	34.9
ADOPT OPEN ADMISSIONS AT PUB COL	37.2	46.8	32.5	28.5	47.8	37.8	23.3	33.1	33.1	32.2	37.5	29.1	26.1
USE SAME DEGREE STANDARD FOR ALL	77.5	77.4	76.7	78.9	77.8	74.0	81.0	76.3	77.0	75.7	75.4	78.3	80.8
CURRENT POLITICAL PREFERENCE													
FAR LEFT	2.8	2.3	2.9	3.2	2.4	1.9	2.0	2.3	5.5	3.0	2.4	3.0	4.0
LIBERAL	35.3	31.5	35.9	40.9	31.5	30.6	33.0	33.8	43.0	35.6	38.3	39.4	46.0
MIDDLE-OF-THE-ROAD	46.8	51.1	45.3	41.9	51.2	49.6	42.0	49.2	37.8	42.4	45.4	43.5	36.0
CONSERVATIVE	14.5	14.3	15.3	13.6	14.0	17.0	22.0	14.1	13.2	18.2	13.5	13.6	13.3
FAR RIGHT	.7	.9	.6	.5	.9	.9	1.1	.6	.5	.7	.4	.5	.6
OBJECTIVES CONSIDERED TO BE ESSENTIAL OR VERY IMPORTANT													
ACHIEVE IN A PERFORMING ART	11.9	9.7	13.7	12.7	9.4	13.0	7.5	12.6	17.8	16.6	13.2	11.9	15.3
BE AN AUTHORITY IN MY FIELD	60.0	58.8	61.4	59.7	58.6	60.7	68.3	61.0	60.2	60.6	59.9	59.4	61.1
OBTAIN RECOGNITION FROM PEERS	37.3	35.9	38.3	38.1	35.7	37.5	46.4	37.3	38.2	36.6	39.1	37.1	41.6
INFLUENCE POLITICAL STRUCTURE	14.1	11.2	15.6	16.4	11.1	12.3	16.5	13.4	20.2	16.1	17.7	15.1	21.4
INFLUENCE SOCIAL VALUES	28.0	25.0	30.6	29.1	24.3	31.9	23.5	28.5	34.8	33.6	35.9	27.9	33.4
RAISE A FAMILY	60.2	60.8	61.9	56.6	60.2	66.8	63.5	61.8	59.3	62.7	64.5	56.8	55.5
HAVE ACTIVE SOCIAL LIFE	55.0	56.4	54.8	52.7	56.4	56.5	55.3	56.5	50.9	52.0	57.1	53.3	50.6
HAVE FRIENDS DIFFERENT FROM ME	60.4	58.6	61.9	61.0	58.3	61.5	55.7	61.8	62.8	62.0	67.5	60.6	62.7
BE AN EXPERT IN FINANCE	13.5	16.1	12.2	11.4	16.3	14.0	13.4	12.6	10.5	11.6	12.4	11.7	10.2
BE ADMINISTRATIVELY RESPONSIBLE	19.7	21.9	19.2	16.8	22.2	19.3	32.6	18.6	16.4	17.2	18.6	17.0	16.2
BE VERY WELL-OFF FINANCIALLY	40.1	44.9	37.0	37.0	45.4	40.3	45.9	38.3	33.5	33.2	34.5	37.6	34.4
HELP OTHERS IN DIFFICULTY	62.7	60.2	66.0	61.5	59.5	67.0	55.8	64.9	67.7	69.7	72.8	60.7	64.4
PARTICIPATE IN PEACE CORPS/VISTA	16.2	14.5	18.0	16.2	14.2	17.5	10.1	17.3	20.0	20.3	21.6	16.2	16.2
BECOME A COMMUNITY LEADER	13.3	11.2	15.7	13.1	10.8	14.9	20.5	14.5	15.3	17.5	14.4	12.4	15.8
CONTRIBUTE TO SCIENTIFIC THEORY	9.0	7.1	8.9	12.3	7.2	6.6	19.6	6.8	9.8	8.5	9.4	11.2	16.4
WRITE ORIGINAL WORKS	13.2	10.2	14.8	15.8	10.0	11.9	10.2	13.1	20.3	16.4	15.4	14.9	18.8
NEVER BE OBLIGATED TO PEOPLE	21.3	22.3	20.6	20.7	22.5	20.9	21.9	20.9	21.3	19.7	17.7	21.0	19.9
CREATE WORKS OF ART	15.4	13.8	15.7	17.6	13.4	17.2	9.7	14.8	20.4	17.1	15.8	18.0	16.4
KEEP UP WITH POLITICAL AFFAIRS	42.8	36.7	45.5	48.8	36.5	38.6	51.1	41.7	49.9	46.5	51.2	46.9	55.7
SUCCEED IN MY OWN BUSINESS	41.9	47.4	38.5	37.8	47.3	48.0	36.0	39.3	37.1	38.9	38.6	38.6	34.9
HELP CLEAN UP ENVIRONMENT	42.9	41.2	44.0	43.9	40.9	43.8	42.5	43.9	45.6	43.8	43.3	44.0	43.6
DEVELOP A PHILOSOPHY OF LIFE	68.1	60.9	72.5	73.4	60.4	65.2	71.4	69.5	76.8	75.4	77.3	72.2	78.0
PARTICIPATE IN COMMUNITY ACTION	25.9	23.2	28.9	25.7	22.9	26.2	22.4	28.5	30.1	30.8	31.7	24.9	28.4
MARRY WITHIN NEXT 5 YEARS	29.8	34.2	29.0	23.6	33.6	40.0	27.9	30.9	23.9	30.3	25.7	25.4	17.2

**AMERICAN COUNCIL ON EDUCATION
OFFICE OF RESEARCH FALL 1971
WEIGHTED NATIONAL NORMS FOR ALL FRESHMEN**

	All Insti- tutions	All 2-Year Colleges	All 4-Year Colleges	All Uni- versities	2-Year Colleges		Technical Institutions	4-Year Colleges				Universities	
					Public	Private		Public	Private Nonsect.	Prot- estant	Catholic	Public	Private
SELF RATINGS OF BETTER THAN 'AVERAGE' ON PERSONAL TRAITS													
ACADEMIC ABILITY	50.6	32.8	56.2	72.1	33.3	27.8	79.0	49.2	63.7	58.7	55.1	69.3	82.7
ATHLETIC ABILITY	36.0	34.6	36.8	36.9	34.7	34.2	50.5	34.7	37.2	37.0	34.3	36.5	38.3
ARTISTIC ABILITY	17.7	15.9	17.6	20.9	15.7	17.1	17.1	15.9	22.2	18.8	17.2	20.6	22.1
CHEERFULNESS	51.6	50.1	53.4	51.4	49.9	52.1	52.2	53.3	52.9	54.9	53.8	51.6	50.8
DEFENSIVENESS	26.8	26.3	26.9	27.6	26.4	25.8	26.8	27.1	26.4	26.6	27.1	27.8	26.9
DRIVE TO ACHIEVE	52.4	44.0	55.6	61.6	43.9	44.2	70.3	51.6	58.7	56.9	55.2	59.2	70.4
LEADERSHIP ABILITY	34.9	27.2	38.0	42.9	27.1	28.2	58.8	32.5	41.9	40.8	36.3	41.0	49.7
MATHEMATICAL ABILITY	32.0	22.5	33.3	46.5	23.0	17.5	67.8	27.1	36.1	32.4	30.8	43.6	57.2
MECHANICAL ABILITY	22.6	23.8	20.0	24.8	24.2	19.5	44.0	17.1	20.4	17.8	16.4	24.2	27.1
ORIGINALITY	34.2	27.7	36.2	42.0	27.4	30.2	41.1	32.3	44.0	38.0	35.8	40.2	48.4
POLITICAL CONSERVATISM	8.6	6.4	9.8	10.6	6.3	7.2	18.6	7.8	9.7	12.2	8.9	9.9	13.4
POLITICAL LIBERALISM	23.0	17.1	24.4	30.9	17.1	16.3	24.4	21.0	32.9	25.7	26.0	29.3	37.1
POPULARITY (GENERAL)	29.2	25.2	31.6	32.3	25.1	25.9	41.7	29.5	32.7	31.9	30.3	31.7	34.9
POPULARITY WITH OPPOSITE SEX	27.2	24.4	28.7	29.7	24.2	26.4	38.8	26.6	30.6	29.3	25.6	29.5	30.6
PUBLIC SPEAKING ABILITY	19.4	13.6	21.9	25.1	13.5	14.6	29.8	18.2	26.3	25.2	20.8	23.4	31.4
SELF-CONFIDENCE (INTELLECTUAL)	34.8	24.8	37.7	47.5	25.0	22.5	56.8	31.7	44.1	39.6	37.5	44.6	58.2
SELF-CONFIDENCE (SOCIAL)	27.4	24.1	29.0	30.2	24.0	25.3	38.6	26.6	31.2	29.4	28.3	29.6	32.6
SENSITIVITY TO CRITICISM	25.4	22.0	26.7	29.1	22.0	21.7	25.3	25.0	30.2	28.3	28.3	28.3	31.9
STUBBORNNESS	36.3	34.4	36.7	39.1	34.6	32.8	39.0	35.7	37.6	36.7	37.8	38.6	40.9
UNDERSTANDING OF OTHERS	62.5	58.2	65.1	65.3	58.0	60.8	63.1	62.8	70.1	67.0	67.6	64.4	68.8
WRITING ABILITY	27.7	20.0	30.6	36.2	20.1	19.9	33.9	26.9	38.2	33.3	29.6	33.7	45.3
STUDENTS ESTIMATE CHANCES ARE VERY GOOD THAT THEY WILL													
GET MARRIED WHILE IN COLLEGE	8.4	7.9	8.7	8.9	7.8	8.3	4.9	10.0	7.2	9.3	6.8	9.9	5.4
MARRY WITHIN A YEAR AFTER COL	19.8	18.2	21.6	19.8	17.8	21.6	27.8	21.0	18.7	23.6	20.4	20.6	16.7
VOTE IN 1972 PRES ELECTION	76.1	71.2	77.5	82.1	71.1	71.4	78.7	76.2	78.8	77.6	81.2	81.7	83.8
ENLIST IN ARMED SERV BEFORE GRAD	1.9	1.1	2.8	1.6	1.1	1.0	23.6	.9	.7	.8	1.0	1.5	1.9
CHANGE MAJOR FIELD	12.5	8.0	14.1	17.6	8.0	8.2	8.6	13.3	17.6	16.4	13.5	17.3	18.9
CHANGE CAREER CHOICE	12.9	8.5	14.3	18.2	8.5	8.9	7.6	12.9	19.1	17.5	13.9	17.7	20.1
FAIL ONE OR MORE COURSES	2.1	1.9	2.4	1.9	1.9	2.1	1.7	2.5	2.4	2.4	1.9	2.1	1.4
GRADUATE WITH HONORS	4.7	3.4	5.0	6.4	3.4	2.8	8.6	3.7	6.3	5.6	5.6	5.7	9.2
BE ELECTED TO A STUDENT OFFICE	1.4	1.1	1.6	1.3	1.1	1.2	2.7	1.1	2.1	1.9	1.8	1.0	2.2
JOIN SOC FRATERNITY OR SORORITY	14.1	10.7	16.8	15.5	10.0	17.8	24.6	14.1	17.8	19.8	17.1	14.0	20.7
BE ELECTED TO AN HONOR SOCIETY	3.1	1.7	3.6	4.8	1.7	2.3	6.6	2.5	4.6	4.3	4.1	4.2	7.1
MAKE AT LEAST A 'B' AVERAGE	23.6	18.6	24.1	31.4	18.9	16.0	35.1	18.6	29.6	27.2	28.8	29.2	39.5
NEED EXTRA TIME TO GET DEGREE	3.8	4.3	3.4	3.7	4.3	4.3	2.8	3.3	3.2	3.8	3.8	4.0	2.6
WORK AT OUTSIDE JOB	33.2	38.6	28.7	31.1	40.3	22.5	17.1	30.1	27.3	27.5	37.0	32.4	26.5
SEEK VOCATIONAL COUNSELING	11.4	9.2	12.7	13.0	9.2	9.4	10.3	12.2	13.5	12.8	16.6	13.1	12.6
SEEK PERSONAL COUNSELING	6.3	4.8	7.9	6.3	4.6	7.0	9.6	6.6	8.8	8.9	9.8	5.8	8.1
ENROLL IN HONORS COURSE	5.7	2.4	6.3	10.5	2.5	2.2	9.7	3.7	9.7	8.3	7.1	8.6	17.2
GET TUTORING HELP IN COURSES	6.0	4.5	7.6	5.9	4.2	7.6	10.9	6.6	9.0	7.4	7.8	5.8	6.2
AUTHOR A PUBLISHED ARTICLE	3.8	2.4	4.5	5.0	2.4	2.6	3.8	3.3	7.4	5.5	4.7	4.3	7.6
BE MORE SUCCESSFUL THAN MOST	8.7	8.7	8.2	9.8	8.8	7.1	11.4	7.3	8.9	8.5	8.1	9.6	10.4
DROP OUT TEMPORARILY	1.4	1.1	1.6	1.7	1.1	1.1	.9	1.3	2.5	1.9	1.5	1.7	1.5
DROP OUT PERMANENTLY	.8	.8	.9	.7	.8	1.0	.9	.9	1.1	1.1	1.0	.7	.6
TRANSFER TO ANOTHER COLLEGE	11.4	13.0	11.5	8.8	12.8	14.7	4.0	12.6	10.9	12.8	11.4	9.6	5.8
BE SATISFIED WITH MY COLLEGE	57.0	55.8	58.3	57.1	55.2	61.3	63.1	56.9	58.3	60.5	57.8	55.5	62.6

**AMERICAN COUNCIL ON EDUCATION
OFFICE OF RESEARCH FALL 1971
WEIGHTED NATIONAL NORMS FOR ALL FRESHMEN**

	All Insti- tutions	All 2-Year Colleges	All 4-Year Colleges	All Uni- versities	2-Year Colleges		Technical Institutions	4-Year Colleges			Universities		
					Public	Private		Public	Private Nonsect.	Prot- estant	Catholic	Public	Private
ACTIVITIES ENGAGED IN BY STUDENTS DURING THE PAST YEAR													
VOTED IN STUDENT ELECTION (3)	64.4	61.0	67.6	65.1	60.4	66.2	64.8	68.3	64.6	69.1	69.2	65.2	64.6
CAME LATE TO CLASS	52.9	51.3	54.2	53.6	50.7	56.6	50.9	52.6	60.3	56.3	50.9	52.7	56.9
PLAYED A MUSICAL INSTRUMENT	37.7	32.2	40.5	42.5	31.9	35.0	36.1	37.7	45.5	47.8	38.2	41.2	47.3
STUDIED IN THE LIBRARY (3)	31.2	28.0	33.5	33.0	27.7	30.8	29.3	33.0	34.7	35.8	34.3	32.5	34.8
CHECKED OUT A LIBRARY BOOK (3)	42.5	37.9	45.9	44.7	37.1	45.4	37.1	46.9	47.8	47.4	43.2	44.1	46.8
ARRANGED DATE FOR STUDENT	42.3	43.9	42.1	40.0	43.0	52.4	38.6	44.0	38.7	41.3	42.7	40.4	38.4
OVERSLEPT AND MISSED A CLASS	21.0	21.9	20.6	20.0	21.9	22.3	17.1	19.4	26.0	20.8	20.3	19.3	22.7
READ ABOUT RIGHTS/RESPONSIBILITY	67.3	62.9	70.5	69.6	61.9	71.8	61.6	71.1	72.6	71.9	69.0	68.7	72.9
TYPED A HOMEWORK ASSIGNMENT (3)	22.4	20.0	23.5	24.4	20.1	18.9	19.7	23.4	24.8	23.5	26.1	24.1	25.9
DISCUSSED FUTURE WITH PARENTS(3)	38.7	37.4	41.1	36.9	36.7	43.1	42.0	39.8	42.3	42.7	42.4	36.3	39.2
WAS LATE WITH SCHOOL ASSIGNMENT	66.7	67.7	66.9	64.8	67.3	71.7	69.3	65.6	69.2	68.5	64.4	65.2	63.5
ARGUED WITH A TEACHER IN CLASS	49.5	44.0	50.8	56.7	44.2	42.3	50.5	47.3	57.9	53.8	51.5	54.9	63.2
ATTENDED A RELIGIOUS SERVICE	86.0	83.8	88.5	85.7	83.2	89.3	88.0	89.1	82.8	90.0	93.5	86.1	84.2
DEMONSTRATED FOR RACIAL CHANGE	15.5	13.1	17.3	16.5	13.1	12.4	10.9	15.4	25.0	18.5	17.7	15.4	20.9
DEMONSTRATED FOR MILITARY CHANGE	11.5	9.7	12.3	13.5	9.7	9.2	8.3	9.6	21.5	13.0	13.1	12.1	18.7
DEMONSTRATED FOR SCHOOL CHANGE	31.5	27.6	34.2	33.9	27.7	26.5	26.6	32.0	42.2	34.2	39.4	32.5	39.1
DID EXTRA READING FOR COURSE (3)	14.2	10.7	15.9	17.6	10.5	11.8	13.8	14.5	20.4	16.4	16.2	16.3	22.6
TOOK SLEEPING PILLS	4.3	4.4	4.3	4.1	4.3	5.3	2.7	4.1	5.1	5.0	4.1	4.1	4.0
TUTORED ANOTHER STUDENT	42.9	32.8	47.8	52.2	32.5	35.3	59.8	43.5	53.0	46.8	52.2	48.8	64.6
PLAYED CHESS	38.4	35.2	38.7	43.3	35.6	31.2	61.0	34.7	39.8	38.4	37.7	41.9	48.2
READ POETRY NOT REQUIRED	59.3	52.2	64.2	63.1	51.3	61.2	50.4	63.7	69.2	67.4	65.6	62.3	65.8
TOOK A TRANQUILIZING PILL	6.2	6.3	6.4	5.8	6.1	8.4	3.3	6.4	7.4	7.5	6.1	5.9	5.5
DISCUSSED RELIGION (3)	25.8	20.2	29.6	28.9	19.5	27.2	23.9	26.6	32.9	36.3	33.4	28.1	32.1
TOOK VITAMINS	58.8	56.8	60.3	59.8	56.3	61.8	58.7	58.3	63.6	64.0	60.3	59.7	60.2
VISITED ART GALLERY OR MUSEUM	66.2	61.5	67.5	71.8	61.1	65.1	64.0	64.6	74.2	70.2	70.0	70.4	77.1
PARTICIPATED IN H.S. POL. CMPG.	36.1	29.9	40.3	39.6	29.0	38.5	40.5	38.6	40.8	42.3	44.8	38.4	44.0
PARTICIPATED IN OTHER POL. CMPG.	13.0	9.2	14.8	16.5	8.8	12.8	13.5	12.7	19.9	14.7	18.0	15.0	22.0
MISSED SCHOOL DUE TO ILLNESS (3)	3.3	3.5	3.3	2.8	3.4	4.4	1.3	3.2	4.5	3.8	3.0	2.7	3.0
SMOKED CIGARETTES (3)	14.9	18.7	13.1	11.5	18.4	21.2	8.9	13.3	14.3	11.6	16.9	11.7	10.6
DISCUSSED POLITICS (3)	21.1	15.5	23.0	27.2	15.3	17.6	27.4	19.3	29.4	24.6	25.1	25.0	35.2
DRANK BEER	60.6	64.1	57.5	59.9	65.4	52.3	66.7	57.2	54.9	50.1	68.3	60.4	57.9
DISCUSSED SPORTS (3)	41.7	40.6	43.5	40.7	40.5	42.3	56.1	43.3	38.0	43.8	41.5	41.1	39.2
READ ABOUT CIVIL RIGHTS	79.9	74.9	82.9	83.3	74.7	76.7	83.0	81.8	84.5	84.3	83.5	82.5	86.2
ASKED TEACHER FOR ADVICE (3)	21.8	17.7	24.7	23.8	17.0	23.9	21.1	22.6	29.2	28.1	25.5	22.5	28.6
HAD VOCATIONAL COUNSELING	46.7	48.7	47.3	42.2	48.4	51.3	44.1	49.9	39.5	45.2	54.6	43.8	36.3
STAYED UP ALL NIGHT	59.9	58.7	60.5	61.0	58.7	58.8	54.3	61.3	62.1	59.2	60.8	60.9	61.3

(**)

THIS ITEM IS REPORTED FOR THE FIRST TIME IN 1971. ITEMS NOT INDICATED WITH '**' ARE REPEATED OR MODIFIED QUESTIONS FROM ONE OR MORE OF THE EARLIER SURVEYS.

- (1) SINCE IT IS POSSIBLE THAT SOME STUDENTS MAY HAVE CHECKED MORE THAN ONE RESPONSE CATEGORY FOR THIS ITEM, THE PERCENTAGES MAY SUM TO MORE THAN 100.
- (2) RECATEGORIZATION OF THIS ITEM FROM A LONGER LIST IS SHOWN IN APPENDIX C OF THE 1971 NAT'L NORMS REPORT.
- (3) FREQUENTLY ONLY, ALL OTHER ITEMS FREQUENTLY PLUS OCCASIONALLY.

AMERICAN COUNCIL ON EDUCATION
OFFICE OF RESEARCH FALL 1971
WEIGHTED NATIONAL NORMS FOR GEOGRAPHIC REGIONS

	MEN				WOMEN				ALL STUDENTS			
	East	Midwest	South	West	East	Midwest	South	West	East	Midwest	South	West
	AGE BY DECEMBER 31, 1971											
16 OR YOUNGER	.1	.0	.1	.0	.2	.1	.1	.1	.1	.0	.1	.0
17	3.7	1.9	2.3	1.5	5.5	3.3	4.6	3.1	4.5	2.5	3.4	2.2
18	71.5	71.1	71.1	64.8	82.1	77.7	77.6	71.6	76.0	74.2	74.4	67.8
19	16.7	17.5	19.7	25.6	8.7	13.5	13.8	20.0	13.3	15.6	16.7	23.1
20	2.8	2.3	2.3	3.2	1.1	1.5	1.4	2.2	2.1	1.9	1.9	2.8
21	.8	1.0	.8	1.2	.5	.7	.5	.4	.7	.9	.6	.8
22-25	3.7	4.3	2.7	2.8	.8	1.1	.6	.8	2.4	2.8	1.7	1.9
26 OR OLDER	.8	1.9	1.1	1.0	1.1	2.2	1.4	1.7	.9	2.0	1.2	1.3
FATHER'S EDUCATION												
GRAMMAR SCHOOL OR LESS	6.4	9.8	9.2	12.8	5.5	10.0	9.2	13.4	6.0	9.9	9.2	13.1
SOME HIGH SCHOOL	17.7	16.2	16.5	15.2	14.5	14.1	16.5	14.7	16.4	15.2	16.5	15.0
HIGH SCHOOL GRADUATE	33.2	34.1	28.6	27.3	31.2	31.7	27.0	24.6	32.3	33.0	27.8	26.1
SOME COLLEGE	15.1	17.5	16.6	17.5	16.3	18.4	17.1	17.9	15.6	17.9	16.9	17.7
COLLEGE DEGREE	18.5	15.5	18.9	18.3	21.4	17.3	19.6	19.3	19.7	16.3	19.2	18.8
POSTGRADUATE DEGREE	9.2	7.0	10.3	8.8	11.0	8.5	10.7	10.0	10.0	7.7	10.5	9.4
MOTHER'S EDUCATION												
GRAMMAR SCHOOL OR LESS	4.1	5.7	4.6	8.8	3.3	6.1	4.8	10.1	3.8	5.9	4.7	9.4
SOME HIGH SCHOOL	13.4	13.1	15.0	13.8	12.4	12.5	15.3	13.5	13.0	12.8	15.1	13.7
HIGH SCHOOL GRADUATE	50.1	49.9	40.8	39.4	45.9	45.1	38.0	35.1	48.3	47.7	39.4	37.5
SOME COLLEGE	14.2	17.3	19.0	20.1	16.2	19.9	21.0	22.7	15.1	18.5	20.0	21.2
COLLEGE DEGREE	15.0	11.9	17.0	15.2	17.9	14.0	17.3	15.3	16.2	12.9	17.2	15.3
POSTGRADUATE DEGREE	3.1	2.1	3.5	2.6	4.3	2.3	3.6	3.4	3.6	2.2	3.6	3.0
RACIAL BACKGROUND (1)												
WHITE/CAUCASIAN	95.2	94.9	85.3	86.1	95.1	93.3	82.4	86.0	95.2	94.1	83.8	86.0
BLACK/NEGRO/AFRO-AMERICAN	2.9	3.9	13.9	4.4	3.4	5.5	17.1	3.8	3.1	4.7	15.5	4.1
AMERICAN INDIAN	.8	.9	.8	1.7	.8	.8	1.0	1.5	.8	.8	.9	1.6
ORIENTAL	.6	.3	.3	1.1	.5	.4	.2	1.1	.5	.3	.3	1.1
MEXICAN-AMERICAN/CHICANO	.1	.3	.1	7.2	.1	.3	.1	7.7	.1	.3	.1	7.4
PUERTO RICAN-AMERICAN	.5	.1	.1	.1	.4	.1	.1	.1	.5	.1	.1	.1
OTHER	1.3	.9	.7	2.0	1.3	1.0	.7	2.1	1.3	1.0	.7	2.0
ESTIMATED PARENTAL INCOME												
LESS THAN \$4,000	3.6	4.0	7.2	7.3	4.1	5.0	8.5	8.6	3.8	4.4	7.8	7.9
\$4,000 - \$5,999	5.7	6.1	7.5	7.8	5.8	6.3	9.0	9.6	5.7	6.2	8.2	8.6
\$6,000 - \$7,999	10.1	9.4	9.4	10.4	9.2	9.8	10.0	10.8	9.8	9.6	9.7	10.6
\$8,000 - \$9,999	13.4	13.3	11.6	12.5	12.7	12.8	10.6	11.3	13.1	13.1	11.1	12.0
\$10,000 - \$12,499	19.0	19.9	15.7	17.5	17.6	20.2	14.9	16.3	18.4	20.0	15.3	17.0
\$12,500 - \$14,999	14.8	15.7	12.9	13.4	14.4	14.4	12.1	12.2	14.7	15.1	12.5	12.9
\$15,000 - \$19,999	14.9	15.1	14.3	12.9	15.1	13.9	13.4	12.0	15.0	14.6	13.8	12.5
\$20,000 - \$24,999	8.0	7.6	8.3	7.6	9.0	7.8	8.6	7.9	8.4	7.7	8.4	7.7
\$25,000 - \$29,999	3.7	3.3	4.4	3.6	4.2	3.4	4.7	3.8	3.9	3.4	4.5	3.7
\$30,000 - \$34,999	2.2	1.9	2.8	2.2	2.6	2.3	3.3	3.0	2.4	2.1	3.0	2.6
\$35,000 - \$39,999	1.3	1.0	1.3	1.1	1.6	1.3	1.5	1.4	1.4	1.1	1.4	1.2
\$40,000 OR MORE	3.3	2.7	4.7	3.7	3.7	2.8	3.5	3.1	3.5	2.7	4.1	3.4

**AMERICAN COUNCIL ON EDUCATION
OFFICE OF RESEARCH FALL 1971
WEIGHTED NATIONAL NORMS FOR GEOGRAPHIC REGIONS**

	MEN				WOMEN				ALL STUDENTS			
	East	Midwest	South	West	East	Midwest	South	West	East	Midwest	South	West
	RELIGION REARED											
PROTESTANT	37.4	48.3	64.9	52.7	39.1	51.6	70.0	56.4	38.1	49.8	67.5	54.4
ROMAN CATHOLIC	48.6	39.1	12.2	27.1	47.0	37.4	10.5	26.7	47.9	38.3	11.4	26.9
JEWISH	6.4	2.4	1.5	1.3	7.4	2.5	1.0	1.3	6.9	2.4	1.3	1.3
OTHER	5.3	7.7	19.0	14.8	4.7	6.6	16.9	12.4	5.0	7.2	18.0	13.7
NONE	2.3	2.6	2.4	4.1	1.8	1.9	1.5	3.2	2.1	2.3	1.9	3.7
RELIGIOUS PREFERENCE												
PROTESTANT	28.3	39.5	55.1	44.2	30.4	44.4	63.4	50.0	29.2	41.8	59.3	46.8
ROMAN CATHOLIC	39.5	33.0	10.0	24.2	39.1	32.8	9.6	25.1	39.3	32.9	9.8	24.6
JEWISH	4.9	1.9	1.2	.9	5.7	2.0	1.0	1.0	5.3	2.0	1.1	1.0
OTHER	8.3	9.8	20.4	16.6	7.8	9.1	18.4	14.1	8.1	9.5	19.4	15.5
NONE	19.0	15.8	13.3	14.1	17.0	11.6	7.6	9.8	18.1	13.8	10.4	12.2
FATHER'S OCCUPATION (2)												
ARTIST (INCL PERFORMER)	.9	.7	.7	.5	1.1	.8	.6	.7	1.0	.7	.7	.6
BUSINESSMAN	30.4	29.2	31.4	26.4	32.2	29.6	28.2	26.0	31.2	29.4	29.8	26.3
CLERGYMAN	.6	.6	1.7	.9	.6	.6	1.7	1.1	.6	.6	1.7	1.0
COLLEGE TEACHER	.7	.6	.8	.8	.9	.8	1.0	1.0	.8	.7	.9	.9
DOCTOR (M.D. OR D.D.S.)	1.8	1.4	2.6	1.8	2.0	1.7	2.2	2.0	1.9	1.5	2.4	1.9
EDUCATOR (SECONDARY)	2.4	1.8	2.3	2.2	2.3	2.2	2.4	2.5	2.3	2.0	2.4	2.3
ELEMENTARY TEACHER	.3	.3	.3	.4	.4	.3	.3	.5	.3	.3	.3	.4
ENGINEER	8.3	6.9	7.2	7.2	8.8	6.9	7.0	7.0	8.5	6.9	7.1	7.1
FARMER OR FORESTER	3.0	9.0	5.0	14.5	2.7	9.0	5.4	14.8	2.9	9.0	5.2	14.7
HEALTH PROFESSIONAL (NON-M.D.)	1.3	1.2	1.2	1.0	1.3	1.1	1.2	1.2	1.3	1.1	1.2	1.1
LAWYER	1.2	1.0	1.4	1.0	1.4	1.1	1.2	1.3	1.3	1.0	1.3	1.1
MILITARY CAREER	1.6	.9	4.7	2.8	.9	.8	4.4	2.2	1.3	.8	4.5	2.5
RESEARCH SCIENTIST	.6	.3	.6	.7	.8	.4	.6	.7	.7	.4	.6	.7
SKILLED WORKER	14.7	15.0	10.6	10.2	12.0	12.2	9.3	7.8	13.5	13.7	9.9	9.2
SEMI-SKILLED WORKER	8.7	9.6	6.6	7.1	6.8	8.3	5.3	4.5	7.9	9.0	5.9	5.9
UNSKILLED WORKER	3.5	4.7	3.2	3.4	3.4	4.5	3.7	3.2	3.5	4.6	3.5	3.3
UNEMPLOYED	1.2	1.1	1.2	1.2	1.5	1.5	2.1	1.8	1.3	1.3	1.7	1.5
OTHER	18.8	15.7	18.5	17.6	21.1	18.2	23.2	21.6	19.8	16.9	20.9	19.4
VETERAN												
NO	95.2	93.7	96.3	95.4	99.9	99.6	99.9	99.8	97.2	96.5	98.1	97.4
YES, SERVED IN SOUTHEAST ASIA	2.3	3.3	2.1	2.9	.0	.0	.0	.1	1.4	1.8	1.1	1.6
YES, DID NOT SERVE IN SE ASIA	2.4	3.0	1.6	1.7	.1	.4	.1	.1	1.4	1.8	.8	1.0
MARITAL STATUS **												
PRESENTLY MARRIED	2.1	4.1	3.0	3.0	1.7	2.9	3.0	3.3	1.9	3.5	3.0	3.2
NOT MARRIED	97.9	95.9	97.0	97.0	98.3	97.1	97.0	96.7	98.1	96.5	97.0	96.8
DISTANCE FROM HOME TO COLLEGE												
5 MILES OR LESS	8.8	14.0	10.4	12.8	9.2	13.3	10.2	15.7	8.9	13.7	10.3	14.1
6-10 MILES	12.2	15.9	9.6	8.1	10.0	15.5	8.4	7.6	11.2	15.7	9.0	7.9
11-50 MILES	30.1	26.0	20.9	27.0	29.5	27.7	20.6	29.7	29.9	26.8	20.7	28.2
51-100 MILES	16.9	10.6	13.2	15.6	17.9	11.7	16.0	16.9	17.3	11.2	14.6	16.2
101-500 MILES	25.6	27.1	33.7	21.5	28.4	25.8	35.1	23.1	26.8	26.5	34.4	22.2
MORE THAN 500 MILES	6.5	6.4	12.2	14.9	5.0	6.1	9.9	7.0	5.9	6.3	11.0	11.4

**AMERICAN COUNCIL ON EDUCATION
OFFICE OF RESEARCH FALL 1971
WEIGHTED NATIONAL NORMS FOR GEOGRAPHIC REGIONS**

	MEN				WOMEN				ALL STUDENTS			
	East	Midwest	South	West	East	Midwest	South	West	East	Midwest	South	West
	AVERAGE GRADE IN HIGH SCHOOL											
A OR A+	4.6	2.8	4.2	7.6	6.9	6.0	8.1	11.0	5.6	4.3	6.1	9.1
A-	6.7	6.2	6.5	10.5	11.4	11.9	11.3	15.5	8.7	8.9	8.9	12.8
B+	13.4	13.6	13.3	16.3	22.3	21.7	21.6	20.4	17.2	17.4	17.5	18.1
B	24.0	21.6	21.7	20.8	30.0	27.9	27.6	24.4	26.6	24.6	24.7	22.4
B-	18.9	19.6	17.1	16.5	14.1	14.9	13.1	12.4	16.9	17.4	15.1	14.7
C+	18.8	20.4	20.5	16.5	10.4	11.4	11.1	9.9	15.2	16.2	15.8	13.5
C	12.6	14.8	15.8	11.2	4.7	5.9	6.9	6.1	9.2	10.6	11.3	8.9
D	1.0	.9	1.0	.6	.2	.2	.3	.2	.6	.6	.7	.4
RANK IN HIGH SCHOOL CLASS												
TOP QUARTER	32.9	35.0	37.2	39.1	47.2	50.8	52.8	48.0	38.9	42.4	45.0	43.0
SECOND QUARTER	29.7	34.6	33.6	29.8	30.4	31.0	29.9	29.7	30.0	32.9	31.7	29.7
THIRD QUARTER	30.9	25.7	25.0	25.8	19.9	16.3	15.1	18.7	26.3	21.3	20.0	22.7
FOURTH QUARTER	6.4	4.7	4.2	5.3	2.5	2.0	2.3	3.6	4.8	3.4	3.3	4.5
SECONDARY SCHOOL ACHIEVEMENTS												
PRESIDENT STUDENT ORGANIZATION	16.3	16.7	22.9	22.2	17.0	17.4	21.8	18.3	16.6	17.1	22.3	20.5
HIGH RATING STATE MUSIC CONTEST	4.7	11.1	9.9	10.4	5.9	17.1	11.9	16.0	5.2	13.9	10.9	12.9
STATE/REGIONAL SPEECH CONTEST	3.1	4.6	4.7	5.7	3.1	6.5	4.7	6.3	3.1	5.5	4.7	5.9
MAJOR PART IN A PLAY	13.0	14.6	15.8	16.4	14.2	15.7	15.9	16.6	13.5	15.1	15.9	16.5
VARSITY LETTER (SPORTS)	47.3	45.2	46.5	50.5	20.8	11.1	17.4	13.6	36.2	29.2	31.9	34.0
AWARD IN ART COMPETITION	4.3	4.9	5.2	5.7	6.3	7.0	5.8	6.2	5.1	5.9	5.5	5.9
EDITOR OF SCHOOL PAPER	8.5	7.7	8.6	7.7	16.7	15.0	14.9	14.5	11.9	11.2	11.8	10.7
ORIGINAL WRITING PUBLISHED	12.1	12.7	13.4	12.2	19.4	17.9	17.3	16.4	15.2	15.1	15.4	14.1
NSF SUMMER PROGRAM	.9	.6	1.0	1.2	.7	.4	.8	.5	.8	.5	.9	.9
STATE/REGIONAL SCIENCE PROGRAM	1.7	2.2	2.8	2.5	1.3	1.7	2.2	1.4	1.6	2.0	2.5	2.0
SCHOLASTIC HONOR SOCIETY	17.5	16.5	20.3	25.0	28.7	29.4	36.6	35.6	22.2	22.5	28.5	29.7
NATIONAL MERIT RECOGNITION	8.3	6.5	6.1	9.6	8.6	7.5	6.9	9.5	8.4	7.0	6.5	9.6
YEAR FINISH SECONDARY SCHOOL **												
GRADUATED IN 1971	88.6	87.4	90.2	89.3	93.7	91.0	92.9	93.4	90.7	89.1	91.5	91.1
DID NOT GRADUATE IN 1971	11.4	12.6	9.8	10.7	6.3	9.0	7.1	6.6	9.3	10.9	8.5	8.9
HIGHEST DEGREE PLANNED												
NONE	7.1	6.9	4.6	6.5	4.7	8.5	4.5	10.3	6.1	7.7	4.5	8.2
ASSOCIATE (OR EQUIVALENT)	11.3	8.2	3.3	7.1	18.0	10.6	7.2	12.6	14.1	9.3	5.3	9.5
BACHELOR'S (B.A., B.S.)	30.8	35.1	37.2	34.1	34.4	45.1	47.9	41.6	32.3	39.8	42.6	37.4
MASTER'S (M.A., M.S.)	25.4	25.7	25.6	24.5	30.4	23.6	28.1	21.4	27.5	24.7	26.9	23.1
PH.D. OR ED.D.	10.6	7.5	10.7	11.0	6.0	4.0	5.9	5.1	8.6	5.9	8.3	8.4
M.D., D.O., D.D.S., OR D.V.M.	6.2	6.5	8.5	7.4	3.0	2.3	2.5	2.3	4.9	4.5	5.5	5.1
LL.B. OR J.D. (LAW)	4.8	6.1	6.8	4.5	1.4	1.0	1.3	1.0	3.4	3.7	4.0	2.9
B.D. (DIVINITY)	.4	.4	.7	.6	.0	.1	.0	.2	.3	.2	.3	.4
OTHER	3.4	3.6	2.7	4.4	2.0	4.9	2.5	5.4	2.8	4.2	2.6	4.8
CONCERN ABOUT FINANCING COLLEGE												
NO CONCERN	35.8	32.4	37.6	37.7	30.9	30.3	36.7	34.2	33.7	31.4	37.1	36.1
SOME CONCERN	55.4	57.4	51.5	52.5	59.4	56.9	52.0	55.1	57.1	57.2	51.8	53.7
MAJOR CONCERN	8.7	10.2	10.9	9.8	9.8	12.8	11.3	10.7	9.2	11.4	11.1	10.2

AMERICAN COUNCIL ON EDUCATION
OFFICE OF RESEARCH FALL 1971
WEIGHTED NATIONAL NORMS FOR GEOGRAPHIC REGIONS

	MEN				WOMEN				ALL STUDENTS			
	East	Midwest	South	West	East	Midwest	South	West	East	Midwest	South	West
MAJOR SOURCES OF FINANCIAL SUPPORT FOR COLLEGE (1)												
PART-TIME OR SUMMER WORK	33.0	40.1	24.9	37.0	23.8	28.6	13.8	21.1	29.1	34.7	19.3	29.9
SAVINGS FROM FULL-TIME EMPLOY	10.5	15.2	8.0	10.7	6.3	9.3	4.4	6.4	8.8	12.4	6.2	8.8
PARENTAL OR FAMILY AID OR GIFTS	49.6	45.0	57.7	43.3	61.5	57.1	66.3	62.5	54.6	50.7	62.0	51.9
PARENT'S MILITARY SERVICE	1.7	1.6	2.7	2.3	1.4	1.5	2.7	2.2	1.6	1.6	2.7	2.2
PERSONAL MILITARY SERVICE	4.5	5.2	3.1	4.7	.1	.2	.2	.2	2.6	2.9	1.6	2.7
SCHOLARSHIPS AND GRANTS	16.8	18.0	18.7	23.7	18.5	23.3	19.3	20.3	17.5	20.5	19.0	22.2
LOANS-NDEA/GOV'T INSURED/COLLEGE	17.7	10.6	13.7	9.8	19.7	13.0	16.4	12.6	18.6	11.7	15.0	11.0
OTHER REPAYABLE LOANS	7.8	3.9	5.3	3.8	9.6	5.0	7.3	4.9	8.6	4.4	6.3	4.3
PROBABLE MAJOR FIELD OF STUDY(2)												
AGRICULTURE (INCL FORESTRY)	5.1	4.8	4.1	9.4	1.6	.3	.3	.6	3.6	2.7	2.2	5.4
BIOLOGICAL SCIENCES	4.9	3.5	5.1	4.3	3.1	2.2	2.7	2.9	4.1	2.9	3.9	3.6
BUSINESS	17.7	20.3	19.0	14.1	13.7	14.4	12.1	18.9	15.9	17.5	15.4	16.2
EDUCATION	4.5	3.9	6.2	4.7	17.5	14.1	18.2	12.3	10.1	8.7	12.3	8.2
ENGINEERING	15.2	12.4	9.9	14.3	.3	.2	.3	.1	8.8	6.6	5.0	7.9
ENGLISH	1.5	.9	1.0	.8	3.8	2.9	3.7	3.7	2.5	1.9	2.4	2.1
HEALTH PROFESSIONS (NON-M.D.)	2.3	2.7	2.6	3.1	13.3	19.9	15.0	14.9	7.0	10.9	8.9	8.5
HISTORY, POLITICAL SCIENCE	5.7	4.1	6.5	4.2	3.4	2.5	3.9	2.4	4.8	3.4	5.2	3.4
HUMANITIES (OTHER)	2.4	1.6	2.5	2.0	5.1	3.8	3.8	3.8	3.5	2.7	3.2	2.8
FINE ARTS	7.3	9.3	8.8	8.5	8.3	11.3	8.9	10.4	7.7	10.3	8.9	9.4
MATHEMATICS OR STATISTICS	2.6	2.6	2.4	2.7	3.0	2.6	3.3	2.5	2.8	2.6	2.8	2.6
PHYSICAL SCIENCES	3.2	2.7	3.0	3.5	1.0	.7	.8	.7	2.3	1.8	1.9	2.2
PRE-PROFESSIONAL	10.2	13.5	15.2	12.0	4.6	3.4	3.9	3.7	7.8	8.7	9.5	8.3
SOCIAL SCIENCES	5.7	5.6	5.6	4.8	13.3	11.4	12.7	11.1	9.0	8.3	9.2	7.7
OTHER FIELDS (TECHNICAL)	7.6	8.4	4.6	7.5	2.7	2.7	2.3	2.3	5.5	5.7	3.5	5.2
OTHER FIELDS (NONTECHNICAL)	2.2	.9	.9	1.3	3.8	4.8	6.0	6.6	2.9	2.7	3.5	3.7
UNDECIDED	1.9	2.6	2.5	2.7	1.6	2.7	2.1	2.9	1.8	2.7	2.3	2.8
PROBABLE CAREER OCCUPATION (2)												
ARTIST (INCL PERFORMER)	4.1	5.7	5.4	4.4	6.3	8.1	7.0	7.8	5.1	6.8	6.2	5.9
BUSINESSMAN	16.2	17.6	16.5	11.4	4.3	4.7	4.4	4.3	11.1	11.5	10.3	8.2
CLERGYMAN	.9	.8	1.7	1.1	.2	.1	.3	.2	.6	.5	1.0	.7
COLLEGE TEACHER	.8	.5	1.1	.7	.6	.4	.9	.6	.7	.5	1.0	.7
DOCTOR (M.D. OR D.D.S.)	5.4	6.6	8.8	5.7	2.1	1.8	2.3	1.9	4.0	4.3	5.5	4.0
EDUCATOR (SECONDARY)	7.0	6.0	7.8	5.2	10.0	10.5	13.7	10.0	8.3	8.2	10.8	7.4
ELEMENTARY TEACHER	1.1	.8	.6	.6	16.3	11.2	15.7	10.7	7.6	5.7	8.3	5.1
ENGINEER	11.2	8.8	8.2	9.4	.3	.2	.2	.1	6.5	4.8	4.1	5.2
FARMER OR FORESTER	4.5	4.7	3.4	7.9	1.1	.4	.4	.6	3.0	2.7	1.9	4.6
HEALTH PROFESSIONAL (NON-M.D.)	3.6	3.6	3.7	5.1	9.0	9.5	7.9	8.4	5.9	6.4	5.8	6.6
LAWYER	5.7	7.1	9.0	5.6	1.5	1.2	1.6	1.2	3.9	4.3	5.2	3.6
NURSE	.3	.3	.3	.4	6.4	10.6	9.0	7.8	2.9	5.2	4.7	3.8
RESEARCH SCIENTIST	3.4	2.9	3.5	4.1	1.9	1.1	1.5	1.5	2.7	2.0	2.5	2.9
OTHER	22.9	21.4	16.9	26.2	26.9	26.3	23.0	29.5	24.6	23.7	20.0	27.7
UNDECIDED	12.7	13.3	12.9	12.2	13.3	13.9	12.2	15.2	13.0	13.6	12.6	13.6

AMERICAN COUNCIL ON EDUCATION
OFFICE OF RESEARCH FALL 1971
WEIGHTED NATIONAL NORMS FOR GEOGRAPHIC REGIONS

	MEN				WOMEN				ALL STUDENTS			
	East	Midwest	South	West	East	Midwest	South	West	East	Midwest	South	West
REASONS NOTED AS VERY IMPORTANT IN DECIDING TO GO TO COLLEGE **												
PARENTS WANTED ME TO GO	20.2	18.8	27.9	25.9	19.9	20.7	32.1	30.3	20.1	19.7	30.0	27.9
CONTRIBUTE MORE TO MY COMMUNITY	14.3	13.3	18.8	15.4	21.4	22.2	27.6	21.6	17.3	17.5	23.3	18.2
GET A BETTER JOB	74.6	77.4	79.9	78.4	64.4	69.9	75.9	74.8	70.3	73.9	77.9	76.8
GAIN A GENERAL EDUCATION	54.5	50.8	54.5	53.8	68.2	64.5	68.5	65.9	60.3	57.3	61.6	59.3
IMPROVE READING/STUDY SKILLS	20.2	20.3	25.5	24.0	20.6	20.4	27.5	26.3	20.4	20.3	26.5	25.0
NOTHING BETTER TO DO	2.2	1.8	2.5	2.7	2.2	2.1	2.4	2.6	2.2	1.9	2.4	2.6
BECOME MORE CULTURED	23.7	21.8	30.1	25.7	32.4	31.7	39.8	33.7	27.4	26.5	35.0	29.3
MAKE MORE MONEY	53.9	56.2	62.3	60.8	35.6	40.2	48.3	48.6	46.2	48.7	55.2	55.3
LEARN MORE ABOUT MY INTERESTS	66.1	63.6	62.8	64.5	75.4	74.3	72.1	72.5	70.0	68.6	67.5	68.1
MEET NEW/INTERESTING PEOPLE	38.4	33.8	37.4	35.0	58.8	54.0	53.1	53.8	47.1	43.3	45.4	43.4
PREPARE FOR GRAD OR PROF SCHOOL	37.4	35.3	45.1	43.1	28.9	24.9	34.0	33.5	33.8	30.4	39.5	38.8
REASONS NOTED AS VERY IMPORTANT IN SELECTING THIS COLLEGE **												
RELATIVES WANTED ME TO GO	5.0	4.8	9.6	8.9	6.0	8.5	13.4	15.3	5.4	6.5	11.5	11.7
COLLEGE HAS A GOOD REPUTATION	34.4	30.7	41.0	36.7	33.7	35.5	46.3	38.7	34.1	33.0	43.6	37.6
MOST FRIENDS GOING TO THIS COL	2.8	3.6	6.7	9.4	2.2	3.3	6.0	11.4	2.6	3.5	6.4	10.3
LOW TUITION	20.0	20.7	14.3	17.6	19.7	20.6	15.2	17.1	19.9	20.7	14.8	17.4
ADVICE OF SOMEONE WHO ATTENDED	14.0	15.1	17.6	16.1	13.4	16.2	18.6	19.5	13.7	15.6	18.1	17.6
SPECIAL EDUC PROGRAM OFFERED	34.0	28.0	25.1	27.8	41.1	35.3	34.1	26.7	37.0	31.5	29.7	27.3
NOT ACCEPTED ANYWHERE ELSE	6.0	1.8	2.6	2.2	4.7	1.2	1.7	1.7	5.5	1.5	2.1	2.0
ADVICE OF GUIDANCE COUNSELOR	10.1	6.4	6.4	5.4	8.0	6.1	6.3	5.0	9.2	6.3	6.3	5.2
WANTED TO LIVE AT HOME	10.1	14.9	9.8	15.5	8.6	15.0	10.0	17.9	9.5	15.0	9.9	16.6
NEED FOR SPECIAL HELP IN (1) **												
ENGLISH	19.6	20.1	22.8	25.1	10.6	9.5	12.2	12.4	15.8	15.1	17.4	19.4
READING	13.9	11.5	11.9	11.7	9.5	7.9	7.7	7.4	12.1	9.8	9.8	9.8
MATHEMATICS	32.9	33.0	37.4	33.8	35.7	37.0	44.5	38.0	34.1	34.9	41.0	35.6
SOCIAL STUDIES	2.8	3.1	3.8	5.3	4.3	3.8	4.1	5.4	3.4	3.4	3.9	5.3
SCIENCE	15.4	15.8	17.3	17.6	27.6	26.1	27.3	25.8	20.5	20.6	22.3	21.2
FOREIGN LANGUAGE	23.0	24.4	28.5	21.3	16.0	16.0	19.8	15.0	20.0	20.4	24.1	18.5
AGREE STRONGLY OR SOMEWHAT												
GOV'T NOT CONTROLLING POLLUTION	91.0	90.5	89.7	88.7	91.7	91.5	89.9	88.2	91.3	91.0	89.8	88.4
GOV'T NOT PROTECTING CONSUMER	77.7	75.5	76.3	73.0	79.7	76.8	75.7	73.9	78.5	76.1	76.0	73.4
GOV'T NOT DESEGREGATING QUICKLY	55.1	52.8	41.1	45.9	60.1	55.9	41.8	46.5	57.2	54.3	41.5	46.2
TOO MANY RIGHTS FOR CRIMINALS	51.6	54.0	54.1	59.9	37.6	41.2	42.2	48.5	45.7	48.0	48.1	54.8
SHOULD ABOLISH DEATH PENALTY	56.8	52.9	53.8	42.5	67.7	62.7	62.3	50.6	61.4	57.5	58.1	46.1
WOMEN'S ACTIVITIES BEST IN HOME	40.9	51.6	54.8	54.8	27.5	29.2	34.7	34.8	40.5	41.1	44.7	45.9
BARELY COMMUNICATE WITH PARENTS	20.8	20.0	20.9	20.1	16.9	15.8	16.1	16.2	19.2	18.0	18.5	18.3
SHOULD LEGALIZE MARIJUANA	47.7	39.7	38.1	34.2	44.7	33.5	27.9	26.5	46.5	36.8	33.0	30.7
SHOULD DISCOURAGE LARGE FAMILIES	67.7	69.9	70.7	70.8	65.8	68.0	68.7	68.2	66.9	69.0	69.7	69.6
WOMEN SHOULD GET JOB EQUALITY	84.1	82.4	82.1	79.7	95.0	94.3	93.5	90.9	88.7	88.0	87.9	84.7
ALL SHOULD GET COL OPPORTUNITY	65.1	68.3	64.4	69.6	70.0	72.1	68.2	74.1	67.2	70.1	66.3	71.6
CAN DO LITTLE TO CHANGE SOCIETY	47.9	46.4	44.1	45.4	40.8	38.6	36.6	37.2	44.9	42.8	40.4	41.7

AMERICAN COUNCIL ON EDUCATION
OFFICE OF RESEARCH FALL 1971
WEIGHTED NATIONAL NORMS FOR GEOGRAPHIC REGIONS

	MEN				WOMEN				ALL STUDENTS			
	East	Midwest	South	West	East	Midwest	South	West	East	Midwest	South	West
AGREE STRONGLY OR SOMEWHAT												
COL REGULATE STUDENTS OFF CAMPUS	12.4	12.9	18.0	16.9	10.0	11.9	18.6	16.8	11.4	12.4	18.3	16.8
BENEFIT OF COLLEGE IS MONETARY	63.3	66.8	67.6	71.0	46.1	50.7	53.9	59.5	56.1	59.2	60.7	65.8
STUDENTS HELP EVALUATE FACULTY	76.3	76.6	75.1	75.9	77.5	77.1	73.2	72.6	76.8	76.8	74.1	74.4
ABOLISH COLLEGE GRADES	41.2	45.5	39.2	36.8	45.2	46.9	40.0	38.5	42.9	46.2	39.6	37.5
DE-EMPHASIZE ORGANIZED SPORTS	26.2	27.7	24.5	30.6	25.2	26.4	21.3	26.6	25.8	27.1	22.9	28.8
REGULATE STUDENT PUBLICATIONS	28.4	31.5	37.1	41.0	24.4	31.0	40.9	42.8	26.7	31.2	39.0	41.8
COLLEGE HAS RIGHT TO BAN SPEAKER	25.8	29.4	32.5	39.6	19.2	25.0	29.2	35.0	23.0	27.3	30.8	37.5
GIVE DISADVANTAGED PREF TRMNT	39.6	39.8	45.4	45.3	36.2	36.8	42.0	42.7	38.2	38.4	43.7	44.1
COL TOO LAX ON STUDENT PROTEST	46.1	49.5	51.5	58.1	36.7	42.5	48.1	50.0	42.1	46.2	49.8	54.5
ADOPT OPEN ADMISSIONS AT PUB COL	35.6	40.3	34.7	41.8	34.5	39.5	32.2	43.2	35.1	39.9	33.4	42.4
USE SAME DEGREE STANDARD FOR ALL	77.2	79.8	77.4	80.8	75.1	77.8	74.4	78.1	76.3	78.9	75.9	79.6
CURRENT POLITICAL PREFERENCE												
FAR LEFT	4.0	3.1	3.4	3.1	2.4	1.4	1.9	1.8	3.3	2.3	2.6	2.5
LIBERAL	38.8	37.5	34.8	31.5	38.0	33.5	30.0	28.6	38.4	35.6	32.4	30.2
MIDDLE-OF-THE-ROAD	42.0	44.5	43.5	46.1	47.3	52.2	51.3	53.6	44.2	48.1	47.4	49.5
CONSERVATIVE	14.3	14.1	17.2	18.1	12.0	12.6	16.4	15.1	13.3	13.4	16.8	16.8
FAR RIGHT	.9	.7	1.2	1.2	.3	.3	.5	.8	.7	.5	.8	1.0
OBJECTIVES CONSIDERED TO BE ESSENTIAL OR VERY IMPORTANT												
ACHIEVE IN A PERFORMING ART	9.9	9.7	11.0	8.9	14.4	13.9	14.7	13.5	11.8	11.7	12.9	11.0
BE AN AUTHORITY IN MY FIELD	62.4	65.0	68.9	65.0	51.6	54.2	60.1	51.3	57.9	59.9	64.4	58.9
OBTAIN RECOGNITION FROM PEERS	42.1	41.0	44.7	41.2	31.9	30.6	33.8	29.2	37.8	36.1	39.2	35.8
INFLUENCE POLITICAL STRUCTURE	18.0	15.9	19.5	15.4	11.2	9.0	11.2	9.0	15.1	12.7	15.3	12.5
INFLUENCE SOCIAL VALUES	27.2	25.1	29.0	24.5	30.4	28.8	31.7	27.3	28.6	26.8	30.4	25.8
RAISE A FAMILY	58.3	53.2	59.0	55.9	65.7	62.5	66.5	64.6	61.4	57.6	62.8	59.8
HAVE ACTIVE SOCIAL LIFE	58.9	55.0	56.8	53.3	54.5	52.7	52.3	51.2	57.0	53.9	54.5	52.3
HAVE FRIENDS DIFFERENT FROM ME	58.8	55.5	57.5	54.8	67.3	64.9	61.2	61.3	62.4	59.9	59.4	57.7
BE AN EXPERT IN FINANCE	16.7	19.2	22.5	20.5	5.1	6.8	9.0	9.3	11.8	13.3	15.7	15.5
BE ADMINISTRATIVELY RESPONSIBLE	24.1	25.4	26.8	25.8	11.2	13.7	14.8	14.4	18.7	19.9	20.7	20.7
BE VERY WELL-OFF FINANCIALLY	50.0	48.7	53.3	50.4	26.0	27.3	31.9	29.8	39.9	38.6	42.5	41.2
HELP OTHERS IN DIFFICULTY	56.7	53.4	58.4	50.6	73.6	70.8	72.9	65.7	63.8	61.5	65.7	57.4
PARTICIPATE IN PEACE CORPS/VISTA	12.7	10.2	11.4	9.6	25.7	21.2	20.4	17.4	18.2	15.3	15.9	13.1
BECOME A COMMUNITY LEADER	14.4	14.3	21.7	17.4	8.3	8.6	14.6	10.0	11.8	11.6	18.1	14.1
CONTRIBUTE TO SCIENTIFIC THEORY	12.3	10.4	12.7	13.4	5.9	4.9	5.9	5.3	9.6	7.8	9.3	9.8
WRITE ORIGINAL WORKS	12.2	10.8	12.2	10.4	17.2	14.5	13.9	13.5	14.3	12.6	13.1	11.8
NEVER BE OBLIGATED TO PEOPLE	23.2	21.8	23.7	22.8	19.1	19.0	21.0	19.9	21.5	20.5	22.3	21.5
CREATE WORKS OF ART	11.5	10.8	11.4	11.1	21.4	20.8	18.5	19.5	15.7	15.5	15.0	14.8
KEEP UP WITH POLITICAL AFFAIRS	44.8	44.3	47.3	41.9	41.0	41.0	41.3	35.4	43.2	42.8	44.2	39.0
SUCCEED IN MY OWN BUSINESS	50.4	51.6	59.0	55.7	25.5	26.5	33.4	34.3	39.9	39.8	46.0	46.1
HELP CLEAN UP ENVIRONMENT	45.9	42.0	45.5	40.5	42.7	40.3	43.5	38.9	44.5	41.2	44.4	39.8
DEVELOP A PHILOSOPHY OF LIFE	63.8	63.2	66.2	59.7	75.0	73.8	73.4	68.5	68.6	68.2	69.9	63.6
PARTICIPATE IN COMMUNITY ACTION	23.0	22.0	28.8	22.9	28.3	26.5	32.7	26.6	25.3	24.1	30.8	24.6
MARRY WITHIN NEXT 5 YEARS	24.3	22.0	26.6	26.3	33.9	34.0	40.3	42.2	28.4	27.7	33.6	33.4

AMERICAN COUNCIL ON EDUCATION
OFFICE OF RESEARCH FALL 1971
WEIGHTED NATIONAL NORMS FOR GEOGRAPHIC REGIONS

	MEN				WOMEN				ALL STUDENTS			
	East	Midwest	South	West	East	Midwest	South	West	East	Midwest	South	West
SELF RATINGS OF BETTER THAN 'AVERAGE' ON PERSONAL TRAITS												
ACADEMIC ABILITY	45.8	54.6	48.0	50.9	47.6	57.1	51.0	50.7	46.5	55.8	49.5	50.8
ATHLETIC ABILITY	44.7	47.2	45.6	45.6	26.2	25.2	21.6	21.7	36.9	36.9	33.5	34.9
ARTISTIC ABILITY	15.9	16.5	15.5	16.3	19.8	21.3	17.2	19.3	17.5	18.8	16.4	17.6
CHEERFULNESS	46.8	48.8	48.7	46.1	53.6	58.4	57.1	56.6	49.7	53.3	52.9	50.8
DEFENSIVENESS	26.5	26.8	27.7	26.5	27.2	27.2	26.8	25.0	26.8	27.0	27.2	25.9
DRIVE TO ACHIEVE	48.1	52.7	53.1	53.0	49.5	56.9	56.5	53.2	48.7	54.6	54.8	53.1
LEADERSHIP ABILITY	36.7	39.5	39.7	40.5	28.5	32.2	30.6	30.4	33.2	36.1	35.1	36.0
MATHEMATICAL ABILITY	37.6	38.8	34.6	38.9	26.7	26.6	23.6	22.6	33.0	33.0	29.1	31.6
MECHANICAL ABILITY	35.8	35.4	30.1	36.6	9.3	8.1	7.2	7.3	24.7	22.6	18.6	23.5
ORIGINALITY	35.0	35.8	33.4	33.7	33.0	35.3	31.8	32.3	34.2	35.6	32.6	33.1
POLITICAL CONSERVATISM	10.1	9.6	11.9	10.7	5.9	6.3	7.8	7.1	8.3	8.1	9.8	9.1
POLITICAL LIBERALISM	27.0	26.9	24.0	21.5	22.7	19.9	17.3	16.1	25.2	23.6	20.6	19.1
POPULARITY (GENERAL)	31.7	33.1	31.5	30.4	25.0	27.8	26.2	23.4	28.9	30.6	28.9	27.3
POPULARITY WITH OPPOSITE SEX	28.9	30.6	32.1	30.8	22.7	24.6	24.5	21.7	26.3	27.8	28.3	26.7
PUBLIC SPEAKING ABILITY	19.9	22.2	21.8	22.0	15.4	18.5	17.1	17.6	18.0	20.5	19.4	20.0
SELF-CONFIDENCE (INTELLECTUAL)	36.1	40.5	38.6	41.8	27.5	32.5	30.6	30.9	32.5	36.8	34.6	36.9
SELF-CONFIDENCE (SOCIAL)	27.8	31.3	31.0	29.9	22.8	26.2	24.8	23.7	25.7	28.9	27.9	27.2
SENSITIVITY TO CRITICISM	24.3	22.8	21.3	22.3	30.9	28.3	25.5	25.8	27.1	25.4	23.4	23.9
STUBBORNNESS	36.2	34.5	34.7	36.6	39.0	37.1	35.4	37.9	37.3	35.7	35.1	37.2
UNDERSTANDING OF OTHERS	60.0	57.8	57.9	56.0	69.2	68.1	66.3	61.7	63.8	62.6	62.1	58.5
WRITING ABILITY	25.6	27.2	26.4	27.1	28.7	31.1	27.6	28.6	26.9	29.0	27.0	27.8
STUDENTS ESTIMATE CHANCES ARE VERY GOOD THAT THEY WILL												
GET MARRIED WHILE IN COLLEGE	4.9	7.9	9.6	9.5	6.4	9.8	11.9	14.9	5.5	8.8	10.8	11.9
MARRY WITHIN A YEAR AFTER COL	17.0	17.0	20.0	19.1	21.2	21.5	24.7	22.2	18.8	19.1	22.3	20.5
VOTE IN 1972 PRES ELECTION	74.4	76.8	78.0	72.0	75.5	78.3	78.3	72.9	74.8	77.5	78.1	72.4
ENLIST IN ARMED SERV BEFORE GRAD	3.3	1.8	2.6	7.0	.2	.4	.4	.4	2.0	1.1	1.5	4.0
CHANGE MAJOR FIELD	10.6	11.7	12.6	13.6	12.4	13.8	13.6	15.3	11.4	12.7	13.1	14.3
CHANGE CAREER CHOICE	11.4	11.9	12.5	12.8	13.6	14.4	13.5	15.6	12.3	13.0	13.0	14.1
FAIL ONE OR MORE COURSES	2.3	1.7	3.8	3.0	1.6	1.2	2.4	1.3	2.0	1.5	3.1	2.2
GRADUATE WITH HONORS	4.9	5.0	5.2	6.1	4.0	4.4	3.8	4.6	4.5	4.7	4.5	5.4
BE ELECTED TO A STUDENT OFFICE	1.4	1.4	2.2	1.5	1.0	.9	1.5	1.1	1.3	1.1	1.8	1.3
JOIN SOC FRATERNITY OR SORORITY	12.8	10.1	16.7	11.9	15.8	12.7	20.2	17.5	14.0	11.3	18.4	14.4
BE ELECTED TO AN HONOR SOCIETY	2.7	2.5	3.2	4.2	2.8	3.4	3.8	4.4	2.7	2.9	3.5	4.3
MAKE AT LEAST A 'B' AVERAGE	22.3	23.2	18.3	25.4	24.1	28.3	20.8	28.2	23.0	25.6	19.6	26.7
NEED EXTRA TIME TO GET DEGREE	3.5	3.8	4.7	4.6	3.0	4.0	3.7	4.1	3.3	3.9	4.2	4.4
WORK AT OUTSIDE JOB	31.3	40.0	26.3	33.7	32.2	40.3	23.4	31.4	31.7	40.2	24.8	32.6
SEEK VOCATIONAL COUNSELING	10.4	11.1	9.8	10.7	12.5	13.1	11.6	12.1	11.3	12.0	10.7	11.3
SEEK PERSONAL COUNSELING	6.9	5.5	6.9	6.2	7.3	4.8	7.2	5.2	7.1	5.2	7.1	5.8
ENROLL IN HONORS COURSE	5.3	4.9	6.2	6.9	5.4	6.1	6.1	6.5	5.3	5.5	6.1	6.7
GET TUTORING HELP IN COURSES	6.3	4.6	7.5	6.4	6.0	4.9	8.0	5.3	6.2	4.7	7.7	5.9
AUTHOR A PUBLISHED ARTICLE	4.2	3.7	4.4	3.9	4.0	3.2	3.4	3.3	4.1	3.5	3.9	3.6
BE MORE SUCCESSFUL THAN MOST	11.0	11.4	12.7	13.0	4.6	5.2	6.0	5.6	8.3	8.5	9.3	9.7
DROP OUT TEMPORARILY	1.3	1.2	1.7	1.6	1.5	1.6	1.3	1.7	1.4	1.4	1.5	1.6
DROP OUT PERMANENTLY	.7	.6	.8	.9	.9	.9	1.0	1.2	.8	.8	.9	1.0
TRANSFER TO ANOTHER COLLEGE	8.4	11.6	12.6	13.9	9.2	12.3	13.8	16.4	8.8	11.9	13.2	15.0
BE SATISFIED WITH MY COLLEGE	52.7	50.4	56.0	49.6	61.7	61.7	65.9	62.9	56.5	55.7	61.0	55.6

AMERICAN COUNCIL ON EDUCATION
OFFICE OF RESEARCH FALL 1971
WEIGHTED NATIONAL NORMS FOR GEOGRAPHIC REGIONS

	MEN				WOMEN				ALL STUDENTS			
	East	Midwest	South	West	East	Midwest	South	West	East	Midwest	South	West
ACTIVITIES ENGAGED IN BY STUDENTS DURING THE PAST YEAR												
VOTED IN STUDENT ELECTION (3)	58.7	59.3	69.8	62.8	63.1	66.1	76.1	70.9	60.5	62.5	72.9	66.5
CAME LATE TO CLASS	56.9	50.0	57.6	53.6	55.0	45.4	54.0	50.6	56.1	47.9	55.8	52.3
PLAYED A MUSICAL INSTRUMENT	34.8	34.5	34.1	35.6	40.7	43.5	39.6	40.6	37.3	38.7	36.9	37.8
STUDIED IN THE LIBRARY (3)	23.8	30.5	28.6	25.9	33.8	40.1	36.1	32.0	28.0	35.0	32.4	28.6
CHECKED OUT A LIBRARY BOOK (3)	32.0	36.5	40.1	36.0	48.3	51.6	54.7	49.3	38.9	43.6	47.4	41.9
ARRANGED DATE FOR STUDENT	42.5	41.9	51.5	42.6	39.7	37.6	46.4	37.9	41.3	39.9	48.9	40.5
OVERSLEPT AND MISSED A CLASS	27.7	21.9	23.4	20.7	21.7	15.5	14.6	14.8	25.1	18.9	18.9	18.1
READ ABOUT RIGHTS/RESPONSIBILITY	61.5	62.3	69.4	61.1	71.0	70.8	77.2	69.9	65.5	66.3	73.3	65.0
TYPED A HOMEWORK ASSIGNMENT (3)	13.9	18.7	14.2	17.3	25.9	35.6	26.5	32.4	19.0	26.6	20.4	24.1
DISCUSSED FUTURE WITH PARENTS (3)	32.9	30.2	34.7	32.5	46.5	44.9	47.7	45.8	38.7	37.1	41.3	38.4
WAS LATE WITH SCHOOL ASSIGNMENT	74.4	68.0	76.0	71.5	64.4	54.5	62.1	60.5	70.2	61.7	69.0	66.6
ARGUED WITH A TEACHER IN CLASS	57.2	55.1	53.5	53.5	47.7	43.4	36.2	38.0	53.2	49.6	44.8	46.6
ATTENDED A RELIGIOUS SERVICE	80.8	83.8	87.4	84.6	85.8	89.6	92.8	89.0	82.9	86.5	90.1	86.6
DEMONSTRATED FOR RACIAL CHANGE	18.3	15.1	19.3	13.6	16.8	12.3	13.8	9.6	17.7	13.7	16.6	11.8
DEMONSTRATED FOR MILITARY CHANGE	17.3	11.6	11.4	8.7	14.7	7.8	6.3	5.8	16.2	9.8	8.8	7.4
DEMONSTRATED FOR SCHOOL CHANGE	35.7	32.3	30.6	26.8	36.0	30.1	26.4	23.2	35.8	31.2	28.5	25.2
DID EXTRA READING FOR COURSE (3)	11.1	12.1	12.5	11.8	16.6	18.1	17.0	16.3	13.4	15.0	14.8	13.8
TOOK SLEEPING PILLS	3.7	3.3	4.0	4.2	5.3	4.3	5.2	5.6	4.4	3.8	4.6	4.8
TUTORED ANOTHER STUDENT	40.5	37.3	43.1	37.2	50.6	43.4	49.8	40.9	44.8	40.2	46.5	38.9
PLAYED CHESS	54.0	52.2	49.3	47.7	25.5	22.9	19.6	18.8	42.0	38.4	34.4	34.7
READ POETRY NOT REQUIRED	45.0	43.5	50.8	44.3	77.1	75.0	76.1	71.5	58.6	58.3	63.6	56.5
TOOK A TRANQUILIZING PILL	4.5	3.7	5.3	5.0	8.4	7.2	9.5	9.4	6.1	5.4	7.4	7.0
DISCUSSED RELIGION (3)	19.1	19.9	24.2	20.4	30.6	31.9	33.8	33.3	24.0	25.5	29.0	26.2
TOOK VITAMINS	53.7	52.3	57.2	60.0	64.9	61.8	62.9	67.6	58.4	56.8	60.1	63.4
VISITED ART GALLERY OR MUSEUM	63.2	63.7	61.0	59.1	74.3	72.9	65.1	64.2	67.9	68.0	63.1	61.3
PARTICIPATED IN H.S. POL. CMPG.	32.0	33.2	42.0	34.8	35.9	35.3	45.0	36.6	33.6	34.2	43.5	35.6
PARTICIPATED IN OTHER POL. CMPG.	12.3	11.0	14.0	10.7	14.6	13.3	15.6	12.6	13.3	12.1	14.8	11.5
MISSED SCHOOL DUE TO ILLNESS (3)	2.4	1.7	2.5	2.1	5.4	3.7	4.5	4.9	3.7	2.6	3.5	3.4
SMOKED CIGARETTES (3)	19.4	15.9	16.1	12.2	18.1	10.8	10.6	7.0	18.9	13.5	13.3	9.9
DISCUSSED POLITICS (3)	24.5	22.7	25.8	20.4	19.9	17.0	18.0	15.3	22.6	20.0	21.9	18.1
DRANK BEER	75.8	70.1	63.8	69.8	54.9	50.7	38.1	43.1	67.0	61.0	50.9	57.9
DISCUSSED SPORTS (3)	51.6	53.7	59.1	51.6	25.3	26.8	31.7	28.3	40.5	41.0	45.3	41.2
READ ABOUT CIVIL RIGHTS	77.9	79.2	82.8	77.0	80.2	81.5	83.1	76.5	78.8	80.3	82.9	76.8
ASKED TEACHER FOR ADVICE (3)	20.2	18.8	23.1	17.9	24.6	22.2	26.2	21.4	22.1	20.4	24.7	19.5
HAD VOCATIONAL COUNSELING	43.6	48.3	44.0	43.6	45.1	52.9	49.0	44.1	44.2	50.5	46.5	43.9
STAYED UP ALL NIGHT	60.6	59.6	60.6	61.5	60.9	60.1	56.6	57.7	60.7	59.8	58.6	59.8

(**)

THIS ITEM IS REPORTED FOR THE FIRST TIME IN 1971. ITEMS NOT INDICATED WITH '***' ARE REPEATED OR MODIFIED QUESTIONS FROM ONE OR MORE OF THE EARLIER SURVEYS.

(1)

SINCE IT IS POSSIBLE THAT SOME STUDENTS MAY HAVE CHECKED MORE THAN ONE RESPONSE CATEGORY FOR THIS ITEM, THE PERCENTAGES MAY SUM TO MORE THAN 100.

(2)

RECATAGORIZATION OF THIS ITEM FROM A LONGER LIST IS SHOWN IN APPENDIX C OF THE 1971 NAT'L NORMS REPORT.

(3)

FREQUENTLY ONLY, ALL OTHER ITEMS FREQUENTLY PLUS OCCASIONALLY.

AMERICAN COUNCIL ON EDUCATION
OFFICE OF RESEARCH FALL 1971
WEIGHTED NATIONAL NORMS

	Colleges for Men		Colleges for Women		Coeducational Colleges						Predominantly Black Colleges		
	Nonsect.	Catholic	Nonsect.	Catholic	Nonsectarian			Catholic			Men	Women	Total
					Men	Women	Total	Men	Women	Total			
AGE BY DECEMBER 31, 1971													
16 OR YOUNGER	.2	.1	.3	.1	.2	.3	.2	.1	.2	.1	.1	.2	.2
17	7.6	3.3	8.4	4.7	4.6	8.4	6.4	3.2	4.8	4.1	5.0	7.6	6.4
18	79.8	83.5	81.5	78.9	74.4	80.0	77.1	78.3	84.9	82.1	59.6	70.1	65.2
19	11.4	11.1	9.1	12.4	16.4	9.4	13.0	15.0	8.6	11.4	22.4	16.5	19.3
20	.4	1.0	.4	1.6	1.9	.8	1.4	1.3	.5	.9	5.1	2.7	3.8
21	.1	.2	.2	.4	.5	.2	.3	.5	.2	.3	1.4	.6	1.0
22-25	.4	.7	.1	1.2	1.6	.5	1.1	1.1	.3	.6	4.9	1.2	2.9
26 OR OLDER	.0	.1	.1	.7	.6	.3	.5	.4	.5	.5	1.5	1.0	1.2
FATHER'S EDUCATION													
GRAMMAR SCHOOL OR LESS	3.0	5.1	3.0	10.1	5.8	5.4	5.6	6.2	6.4	6.3	21.7	23.0	22.4
SOME HIGH SCHOOL	6.2	11.7	5.8	10.7	12.5	10.9	11.7	14.5	11.1	12.6	30.3	28.5	29.4
HIGH SCHOOL GRADUATE	15.2	29.0	14.1	26.4	25.2	22.7	24.0	30.8	31.3	31.1	25.3	24.4	24.8
SOME COLLEGE	13.1	18.3	14.6	19.3	16.2	17.1	16.7	17.0	18.6	17.9	9.7	10.1	9.9
COLLEGE DEGREE	30.8	22.0	32.0	22.2	23.6	24.8	24.2	21.9	20.2	21.0	8.4	8.4	8.4
POSTGRADUATE DEGREE	31.7	13.9	30.6	11.4	16.6	19.1	17.8	9.6	12.3	11.1	4.7	5.5	5.1
MOTHER'S EDUCATION													
GRAMMAR SCHOOL OR LESS	1.4	3.7	1.3	7.2	3.9	3.0	3.5	4.1	3.2	3.6	10.6	10.6	10.6
SOME HIGH SCHOOL	4.9	9.8	4.7	10.0	10.8	9.0	9.9	11.9	9.4	10.5	30.5	29.0	29.7
HIGH SCHOOL GRADUATE	29.1	48.9	23.1	39.7	39.0	35.2	37.1	51.0	48.5	49.6	32.4	30.8	31.5
SOME COLLEGE	21.1	17.4	24.5	20.9	18.6	21.7	20.1	15.2	19.3	17.6	10.2	13.1	11.7
COLLEGE DEGREE	33.3	16.6	33.9	18.7	21.2	22.8	22.0	15.4	16.8	16.2	11.3	11.2	11.3
POSTGRADUATE DEGREE	10.2	3.6	12.3	3.6	6.4	8.4	7.4	2.4	2.8	2.6	5.0	5.3	5.2
RACIAL BACKGROUND (1)													
WHITE/CAUCASIAN	92.8	95.1	81.2	90.2	86.1	85.1	85.6	94.6	93.9	94.2	4.6	2.2	3.3
BLACK/NEGRO/AFRO-AMERICAN	5.3	3.0	16.9	3.1	12.0	13.3	12.6	2.9	3.5	3.2	94.7	97.5	96.2
AMERICAN INDIAN	.9	.6	1.1	.9	1.1	1.1	1.1	.8	.4	.6	.9	.7	.8
ORIENTAL	1.0	.3	1.1	1.0	.6	.8	.7	.6	.6	.6	.2	.2	.2
MEXICAN-AMERICAN/CHICANO	.5	.6	.1	5.1	.2	.3	.2	1.2	.8	1.0	.0	.0	.0
PUERTO RICAN-AMERICAN	.5	.6	.2	.3	.2	.3	.2	.3	.5	.4	.2	.0	.1
OTHER	1.0	1.2	1.6	1.5	1.4	1.2	1.3	1.5	1.8	1.6	.6	.5	.5
ESTIMATED PARENTAL INCOME													
LESS THAN \$4,000	2.1	2.5	3.4	5.8	4.8	4.7	4.8	2.9	3.5	3.2	24.8	26.2	25.5
\$4,000 - \$5,999	3.0	4.0	4.1	6.7	5.4	6.4	5.9	4.7	5.3	5.0	20.0	20.8	20.4
\$6,000 - \$7,999	5.0	6.3	5.1	8.6	7.1	8.5	7.7	7.3	8.3	7.8	14.1	14.9	14.5
\$8,000 - \$9,999	6.2	10.4	4.9	10.2	9.1	10.1	9.6	12.0	11.0	11.4	11.2	10.9	11.1
\$10,000 - \$12,499	9.3	17.2	9.3	16.8	14.9	13.3	14.2	18.3	18.2	18.2	10.9	9.2	10.0
\$12,500 - \$14,999	9.6	16.0	8.8	12.7	12.7	12.3	12.5	15.7	15.0	15.3	6.1	6.0	6.1
\$15,000 - \$19,999	15.1	16.9	12.2	13.6	15.0	15.1	15.0	16.0	14.9	15.4	6.3	5.6	5.9
\$20,000 - \$24,999	12.6	10.9	12.0	9.4	10.2	10.6	10.4	8.4	8.5	8.4	3.1	3.0	3.1
\$25,000 - \$29,999	8.7	5.4	8.5	4.3	6.0	5.8	5.9	3.9	5.4	4.7	1.4	1.4	1.4
\$30,000 - \$34,999	6.7	3.5	8.1	3.7	4.3	4.0	4.2	3.4	3.4	3.4	.7	.9	.8
\$35,000 - \$39,999	5.1	1.7	5.6	2.0	2.7	2.3	2.5	2.1	2.3	2.2	.5	.4	.5
\$40,000 OR MORE	16.8	5.1	18.0	6.1	7.8	6.8	7.3	5.3	4.3	4.7	.9	.7	.8

**AMERICAN COUNCIL ON EDUCATION
OFFICE OF RESEARCH FALL 1971
WEIGHTED NATIONAL NORMS**

	Colleges for Men		Colleges for Women		Coeducational Colleges						Predominantly Black Colleges		
					Nonsectarian			Catholic					
	Nonsect.	Catholic	Nonsect.	Catholic	Men	Women	Total	Men	Women	Total	Men	Women	Total
AVERAGE GRADE IN HIGH SCHOOL													
A OR A+	13.2	5.3	11.3	7.0	4.7	9.9	7.3	4.0	7.6	6.1	.6	1.9	1.3
A-	23.4	9.7	18.3	13.1	8.0	16.0	12.0	6.1	11.8	9.3	1.8	6.2	4.1
B+	24.0	20.8	26.2	22.6	17.2	26.1	21.6	17.4	23.3	20.8	9.1	18.6	14.1
B	18.2	29.9	23.6	27.5	26.4	26.4	26.4	27.4	29.6	28.7	19.1	28.8	24.3
B-	9.5	17.8	10.9	13.0	17.5	11.0	14.3	18.3	15.0	16.4	18.6	16.5	17.5
C+	4.1	11.7	6.5	9.4	15.3	6.9	11.1	15.6	8.8	11.7	28.6	17.1	22.5
C	2.6	4.7	3.2	7.0	10.1	3.5	6.8	10.5	3.8	6.7	20.9	10.5	15.3
D	.0	.2	.1	.4	.8	.3	.5	.7	.0	.3	1.3	.5	.9
RANK IN HIGH SCHOOL CLASS													
TOP QUARTER	74.9	41.5	59.4	50.5	41.5	59.4	50.2	34.7	44.9	40.5	20.7	33.2	27.3
SECOND QUARTER	17.4	34.7	27.1	29.5	33.0	26.3	29.8	35.4	34.2	34.7	35.8	33.9	34.8
THIRD QUARTER	6.7	21.1	11.8	15.8	20.9	12.2	16.7	24.8	18.9	21.4	37.0	28.8	32.6
FOURTH QUARTER	.9	2.7	1.7	4.2	4.5	2.1	3.3	5.1	2.1	3.4	6.4	4.2	5.2
SECONDARY SCHOOL ACHIEVEMENTS													
PRESIDENT STUDENT ORGANIZATION	33.7	20.3	28.6	23.4	21.8	20.7	21.3	19.2	21.0	20.2	26.6	26.6	26.6
HIGH RATING STATE MUSIC CONTEST	6.7	4.1	11.0	10.3	8.8	12.6	10.6	5.2	8.7	7.2	10.9	10.8	10.8
STATE/REGIONAL SPEECH CONTEST	8.1	5.1	7.5	8.8	4.9	5.0	5.0	5.3	6.9	6.2	5.4	8.2	6.9
MAJOR PART IN A PLAY	18.8	13.9	23.6	19.5	17.0	18.2	17.6	15.7	15.5	15.6	24.5	24.1	24.3
VARSITY LETTER (SPORTS)	54.6	41.5	19.3	18.8	48.6	15.8	32.6	46.2	15.0	28.5	48.6	13.4	29.9
AWARD IN ART COMPETITION	5.9	4.7	10.2	8.5	5.5	7.6	6.5	3.9	6.6	5.4	7.2	4.9	6.0
EDITOR OF SCHOOL PAPER	21.8	13.8	23.9	19.2	11.4	17.5	14.4	11.4	16.1	14.1	9.5	14.4	12.1
ORIGINAL WRITING PUBLISHED	27.0	17.7	28.1	23.9	18.7	23.8	21.2	16.1	21.3	19.0	11.7	14.7	13.3
NSF SUMMER PROGRAM	2.8	.6	1.1	.5	1.0	.8	.9	.6	.5	.6	1.5	1.4	1.5
STATE/REGIONAL SCIENCE PROGRAM	2.8	1.6	2.2	2.1	2.2	1.8	2.0	1.8	1.6	1.7	3.6	4.0	3.8
SCHOLASTIC HONOR SOCIETY	51.6	27.1	41.5	32.8	21.4	37.8	29.5	19.0	31.7	26.2	11.8	26.4	19.6
NATIONAL MERIT RECOGNITION	28.7	8.0	16.1	7.9	13.5	18.5	16.0	8.0	8.1	8.0	6.4	9.3	7.9
YEAR FINISH SECONDARY SCHOOL **													
GRADUATED IN 1971	97.3	96.5	96.5	94.3	93.1	94.7	93.9	94.3	96.2	95.4	83.3	89.8	86.8
DID NOT GRADUATE IN 1971	2.7	3.5	3.5	5.7	6.9	5.3	6.1	5.7	3.8	4.6	16.7	10.2	13.2
HIGHEST DEGREE PLANNED													
NONE	2.7	3.7	3.4	5.1	4.2	4.4	4.3	4.3	4.5	4.4	7.0	6.0	6.5
ASSOCIATE (OR EQUIVALENT)	.4	.5	1.5	1.1	.4	1.1	.7	.5	1.1	.9	1.8	2.5	2.2
BACHELOR'S (B.A., B.S.)	18.9	31.1	31.6	46.6	31.4	40.5	35.9	33.4	46.2	40.7	27.9	25.6	26.7
MASTER'S (M.A., M.S.)	23.8	31.2	35.9	33.1	27.3	35.4	31.3	28.2	34.4	31.7	35.8	46.0	41.2
PH.D. OR ED.D.	18.8	10.7	15.6	6.6	14.8	10.1	12.5	11.6	5.4	8.1	15.4	14.0	14.7
M.D., D.O., D.D.S., OR D.V.M.	17.9	10.3	5.9	3.1	9.4	3.6	6.6	9.7	3.1	6.0	3.7	2.8	3.2
LL.B. OR J.D. (LAW)	15.6	10.8	4.6	1.9	9.3	2.6	6.0	9.9	1.7	5.2	5.5	2.1	3.7
B.D. (DIVINITY)	.4	.4	.1	.3	1.2	.1	.6	.5	.0	.2	.4	.1	.2
OTHER	1.6	1.3	1.4	2.1	2.0	2.3	2.1	1.9	3.4	2.8	2.4	.9	1.6
CONCERN ABOUT FINANCING COLLEGE													
NO CONCERN	39.2	28.5	43.0	26.4	33.6	30.6	32.2	25.4	25.4	25.4	23.4	18.2	20.6
SOME CONCERN	51.6	59.7	46.3	58.3	54.7	56.1	55.4	62.5	61.2	61.8	52.6	55.5	54.1
MAJOR CONCERN	9.3	11.9	10.7	15.3	11.6	13.3	12.5	12.2	13.4	12.9	24.1	26.3	25.3

**AMERICAN COUNCIL ON EDUCATION
OFFICE OF RESEARCH FALL 1971
WEIGHTED NATIONAL NORMS**

	Colleges for Men		Colleges for Women		Coeducational Colleges						Predominantly Black Colleges		
	Nonsect.	Catholic	Nonsect.	Catholic	Nonsectarian			Catholic			Men	Women	Total
					Men	Women	Total	Men	Women	Total			
MAJOR SOURCES OF FINANCIAL SUPPORT FOR COLLEGE (1)													
PART-TIME OR SUMMER WORK	19.8	31.1	9.2	24.9	24.5	15.5	20.1	33.5	22.7	27.4	24.7	18.6	21.4
SAVINGS FROM FULL-TIME EMPLOY	4.3	7.4	2.7	6.3	7.2	4.2	5.7	8.1	6.1	6.9	9.1	6.3	7.6
PARENTAL OR FAMILY AID OR GIFTS	79.0	60.7	78.2	57.5	64.7	69.3	66.9	55.9	59.6	58.0	34.1	42.2	38.4
PARENT'S MILITARY SERVICE	1.1	1.3	1.4	2.2	1.7	1.6	1.6	1.6	1.6	1.6	3.8	2.9	3.3
PERSONAL MILITARY SERVICE	.4	.5	.2	.4	1.7	.1	.9	1.5	.1	.7	6.0	.6	3.1
SCHOLARSHIPS AND GRANTS	27.7	27.1	21.4	36.0	25.7	29.3	27.5	26.7	30.5	28.8	31.6	31.8	31.7
LOANS-NDEA/GOV'T INSURED/COLLEGE	19.9	24.4	18.0	28.0	20.5	23.0	21.8	24.0	26.1	25.2	22.5	31.1	27.0
OTHER REPAYABLE LOANS	6.8	9.6	6.6	7.9	8.4	9.7	9.0	8.5	10.0	9.3	10.8	13.6	12.3
PROBABLE MAJOR FIELD OF STUDY(2)													
AGRICULTURE (INCL FORESTRY)	7.3	.4	.1	.5	1.3	.3	.8	.5	.0	.2	1.3	.2	.7
BIOLOGICAL SCIENCES	8.2	4.9	5.2	2.9	5.1	3.9	4.5	4.6	3.0	3.7	4.2	2.3	3.2
BUSINESS	5.5	18.1	3.0	4.3	16.9	5.5	11.2	24.1	4.6	12.8	23.7	18.1	20.6
EDUCATION	.9	3.8	6.4	13.0	4.4	12.2	8.3	4.2	15.9	11.0	9.8	16.2	13.3
ENGINEERING	1.4	2.9	.2	.7	5.0	.2	2.6	4.8	.5	2.3	6.9	.4	3.3
ENGLISH	4.7	4.0	6.3	4.1	2.1	4.3	3.2	2.9	5.8	4.6	.7	3.7	2.4
HEALTH PROFESSIONS (NON-M.D.)	.7	4.2	3.4	22.2	4.8	11.3	8.0	2.4	18.6	11.8	2.2	10.6	6.9
HISTORY, POLITICAL SCIENCE	12.9	10.5	8.0	3.9	7.9	5.5	6.7	9.1	5.1	6.8	10.3	5.5	7.7
HUMANITIES (OTHER)	4.7	4.8	9.2	6.4	4.9	6.6	5.7	2.9	5.0	4.1	1.4	1.6	1.5
FINE ARTS	5.0	3.5	20.3	14.5	8.8	14.5	11.6	5.2	7.8	6.7	10.3	7.0	8.5
MATHEMATICS OR STATISTICS	3.2	4.0	3.4	4.0	2.9	3.6	3.2	3.1	5.2	4.3	2.2	2.3	2.3
PHYSICAL SCIENCES	5.1	2.5	1.2	1.1	3.0	1.0	2.0	2.6	.9	1.6	1.5	1.2	1.4
PRE-PROFESSIONAL	25.5	19.5	8.6	4.8	16.4	5.2	10.8	17.8	3.9	9.8	7.7	4.1	5.7
SOCIAL SCIENCES	9.9	12.9	17.2	11.8	9.5	19.4	14.4	9.8	16.3	13.5	11.7	19.8	16.2
OTHER FIELDS (TECHNICAL)	2.2	2.3	2.8	1.3	4.3	1.8	3.0	3.9	2.1	2.8	4.7	1.7	3.1
OTHER FIELDS (NONTECHNICAL)	.3	.4	2.5	2.6	.6	2.4	1.5	.4	3.8	2.4	.4	4.1	2.4
UNDECIDED	2.6	1.2	1.9	1.9	2.3	2.4	2.4	1.8	1.3	1.5	.7	1.1	.9
PROBABLE CAREER OCCUPATION (2)													
ARTIST (INCL PERFORMER)	5.1	3.6	16.2	11.6	7.7	10.8	9.3	4.8	6.1	5.6	8.1	6.9	7.4
BUSINESSMAN	7.4	17.1	3.0	3.3	15.4	2.7	9.1	21.7	3.3	11.1	22.0	9.9	15.3
CLERGYMAN	.5	2.7	.2	1.0	2.8	.3	1.5	2.2	.2	1.1	.4	.1	.2
COLLEGE TEACHER	2.0	.9	1.5	.6	1.3	1.0	1.2	.7	.4	.5	1.8	2.2	2.0
DOCTOR (M.D. OR D.D.S.)	16.1	11.1	5.2	2.9	9.5	3.1	6.3	10.8	2.7	6.2	5.1	2.9	3.9
EDUCATOR (SECONDARY)	3.2	9.1	7.3	9.3	6.4	10.4	8.4	8.4	10.5	9.6	11.0	11.1	11.1
ELEMENTARY TEACHER	.6	2.3	6.7	15.0	1.0	9.9	5.4	1.8	17.1	10.5	2.3	13.4	8.4
ENGINEER	1.2	2.6	.3	.6	4.1	.1	2.1	4.3	.5	2.1	6.4	.4	3.1
FARMER OR FORESTER	4.5	.8	.6	.7	2.3	.7	1.5	.9	.2	.5	.5	.1	.3
HEALTH PROFESSIONAL (NON-M.D.)	3.4	2.3	3.5	7.9	5.1	9.6	7.3	2.0	7.6	5.2	2.1	6.3	4.4
LAWYER	16.6	13.0	5.3	2.1	10.9	2.7	6.8	11.7	2.1	6.2	8.6	3.1	5.5
NURSE	.0	2.5	.8	15.6	.1	3.6	1.8	.4	13.1	7.7	.2	6.6	3.7
RESEARCH SCIENTIST	6.8	3.1	3.6	1.9	3.5	2.4	3.0	3.3	1.7	2.4	1.9	1.0	1.4
OTHER	11.8	15.7	23.8	17.0	13.3	24.1	18.7	14.3	21.3	18.3	20.5	28.8	25.1
UNDECIDED	21.0	13.2	22.0	10.6	16.5	18.6	17.6	12.8	13.2	13.0	9.2	7.4	8.2

AMERICAN COUNCIL ON EDUCATION
OFFICE OF RESEARCH FALL 1971
WEIGHTED NATIONAL NORMS

	Colleges for Men		Colleges for Women		Coeducational/ Colleges						Predominantly Black Colleges		
	Nonsect.	Catholic	Nonsect.	Catholic	Nonsectarian			Catholic			Men	Women	Total
					Men	Women	Total	Men	Women	Total			
REASONS NOTED AS VERY IMPORTANT IN DECIDING TO GO TO COLLEGE **													
PARENTS WANTED ME TO GO	22.6	21.9	30.1	25.2	23.8	25.2	24.5	23.0	23.3	23.2	40.9	42.6	41.8
CONTRIBUTE MORE TO MY COMMUNITY	22.2	23.3	26.9	30.3	19.6	26.4	23.0	18.1	29.6	24.6	36.1	39.6	38.0
GET A BETTER JOB	58.6	68.4	58.5	60.0	67.0	56.6	61.9	70.9	64.5	67.2	88.4	89.1	88.8
GAIN A GENERAL EDUCATION	72.1	62.5	79.4	67.8	60.9	73.8	67.3	55.9	71.1	64.5	64.0	73.4	69.0
IMPROVE READING/STUDY SKILLS	18.2	20.4	23.6	22.3	22.9	22.0	22.5	21.7	21.3	21.5	44.3	47.6	46.1
NOTHING BETTER TO DO	2.2	1.4	3.0	1.6	2.3	2.8	2.6	1.8	1.8	1.8	5.2	4.1	4.6
BECOME MORE CULTURED	27.3	30.6	43.0	39.3	26.8	36.6	31.6	26.0	37.5	32.5	48.3	55.6	52.3
MAKE MORE MONEY	34.2	42.6	28.5	30.1	46.7	29.5	38.3	49.8	30.9	39.0	74.2	68.6	71.2
LEARN MORE ABOUT MY INTERESTS	79.5	65.9	83.8	75.6	68.7	78.5	73.5	58.8	75.1	68.1	69.0	74.8	72.1
MEET NEW/INTERESTING PEOPLE	48.4	47.7	64.7	58.8	42.4	60.9	51.5	42.6	59.5	52.3	40.1	49.0	44.9
PREPARE FOR GRAD OR PROF SCHOOL	51.0	44.9	40.3	30.4	42.2	32.3	37.4	44.6	28.6	35.5	54.9	59.8	57.5
REASONS NOTED AS VERY IMPORTANT IN SELECTING THIS COLLEGE **													
RELATIVES WANTED ME TO GO	4.9	6.6	9.9	9.6	5.8	8.0	6.9	5.6	9.2	7.7	13.3	14.5	13.9
COLLEGE HAS A GOOD REPUTATION	57.0	44.9	49.2	47.2	41.4	45.8	43.6	35.3	42.6	39.5	37.9	42.8	40.5
MOST FRIENDS GOING TO THIS COL	.8	1.7	.8	1.2	1.6	1.9	1.8	1.5	2.1	1.8	7.7	4.9	6.2
LOW TUITION	1.3	3.5	1.6	4.8	5.6	5.9	5.7	6.6	5.1	5.7	15.0	14.9	14.9
ADVICE OF SOMEONE WHO ATTENDED	15.7	19.4	14.5	17.4	15.7	15.2	15.4	18.6	17.3	17.8	20.2	17.5	18.7
SPECIAL EDUC PROGRAM OFFERED	39.3	28.2	48.3	39.2	32.3	42.2	37.2	23.9	36.0	30.9	28.8	24.3	31.8
NOT ACCEPTED ANYWHERE ELSE	4.0	3.7	2.9	2.3	4.2	2.5	3.4	3.6	2.7	3.1	3.6	1.8	2.6
ADVICE OF GUIDANCE COUNSELOR	7.8	8.9	5.8	6.8	8.8	6.8	7.8	10.0	7.0	8.3	10.1	8.1	9.0
WANTED TO LIVE AT HOME	1.6	8.8	2.5	8.3	6.6	4.7	5.7	9.9	10.8	10.5	13.0	11.1	12.0
NEED FOR SPECIAL HELP IN (1) **													
ENGLISH	11.3	13.1	11.0	11.8	18.6	11.2	15.0	16.7	9.5	12.6	24.1	15.9	19.8
READING	9.2	11.3	8.1	8.7	12.7	8.2	10.5	10.4	6.7	8.3	11.6	8.9	10.1
MATHEMATICS	24.7	37.5	38.0	39.2	33.3	38.5	35.8	37.4	40.1	38.9	51.5	62.5	57.4
SOCIAL STUDIES	1.8	2.9	3.1	4.4	3.0	4.5	3.7	2.1	4.8	3.6	4.5	6.9	5.8
SCIENCE	19.5	22.8	26.8	29.9	17.4	27.7	22.5	20.8	32.3	27.4	20.5	31.4	26.3
FOREIGN LANGUAGE	19.2	30.5	22.5	24.0	31.3	22.8	27.2	32.5	25.4	28.4	40.6	32.8	36.4
AGREE STRONGLY OR SOMEWHAT													
GOV'T NOT CONTROLLING POLLUTION	94.7	91.9	93.4	90.9	91.9	92.4	92.2	90.9	91.4	91.2	88.5	89.0	88.8
GOV'T NOT PROTECTING CONSUMER	82.6	78.7	82.2	75.7	80.5	81.4	80.9	77.0	77.8	77.4	78.7	81.5	80.2
GOV'T NOT DESEGREGATING QUICKLY	62.0	53.7	61.4	53.1	57.1	58.9	57.9	52.1	54.6	53.5	69.4	70.9	70.2
TOO MANY RIGHTS FOR CRIMINALS	37.5	47.4	30.6	40.0	46.6	33.7	40.3	47.7	36.2	41.1	38.7	32.4	35.3
SHOULD ABOLISH DEATH PENALTY	68.5	65.9	70.2	69.3	60.1	67.5	63.7	60.3	69.5	65.5	68.6	68.4	68.5
WOMEN'S ACTIVITIES BEST IN HOME	29.6	44.2	21.5	32.9	46.5	26.3	36.6	54.3	31.1	41.1	62.7	42.9	52.1
BARELY COMMUNICATE WITH PARENTS	14.8	16.9	12.4	14.3	18.5	14.7	16.6	20.0	14.3	16.8	23.0	19.2	21.0
SHOULD LEGALIZE MARIJUANA	57.8	42.7	51.8	33.1	48.9	43.5	46.3	44.5	36.2	39.8	40.6	27.2	33.4
SHOULD DISCOURAGE LARGE FAMILIES	81.4	55.1	71.8	51.1	72.0	70.9	71.4	55.2	49.4	51.9	46.7	44.9	45.7
WOMEN SHOULD GET JOB EQUALITY	92.3	86.6	96.3	93.4	85.7	94.9	90.2	82.6	94.7	89.5	80.2	91.4	86.2
ALL SHOULD GET COL OPPORTUNITY	54.1	61.2	65.2	69.9	63.4	68.5	65.9	64.4	68.7	66.9	82.1	83.7	82.9
CAN DO LITTLE TO CHANGE SOCIETY	44.8	42.2	40.1	33.7	46.3	39.4	43.0	43.2	36.0	39.1	49.1	45.4	47.1

**AMERICAN COUNCIL ON EDUCATION
OFFICE OF RESEARCH FALL 1971
WEIGHTED NATIONAL NORMS**

	Colleges for Men			Colleges for Women			Coeducational Colleges			Predominantly Black Colleges			
	Nonsect.		Catholic	Nonsect.		Catholic	Nonsectarian		Catholic		Men	Women	Total
	Men	Women	Total	Men	Women	Total	Men	Women	Total				
AGREE STRONGLY OR SOMEWHAT													
COL REGULATE STUDENTS OFF CAMPUS	8.5	10.7	10.8	13.5	13.3	13.6	13.4	13.6	10.6	11.9	32.2	27.3	29.6
BENEFIT OF COLLEGE IS MONETARY	36.6	49.8	36.3	39.6	56.3	39.6	48.1	59.0	42.6	49.7	78.5	72.2	75.1
STUDENTS HELP EVALUATE FACULTY	79.2	76.8	77.5	74.0	76.2	76.9	76.5	72.8	75.3	74.2	75.1	69.1	71.9
ABOLISH COLLEGE GRADES	40.6	47.4	51.5	49.1	45.0	48.0	46.5	45.4	47.0	46.3	37.4	37.3	37.4
DE-EMPHASIZE ORGANIZED SPORTS	33.9	23.6	31.6	27.1	30.2	29.8	30.0	25.1	23.6	24.2	24.9	24.0	24.4
REGULATE STUDENT PUBLICATIONS	15.6	25.9	20.7	30.7	25.0	26.2	25.6	27.4	28.5	28.0	48.4	49.0	48.7
COLLEGE HAS RIGHT TO BAN SPEAKER	15.3	23.3	16.1	26.3	23.6	21.0	22.3	27.8	24.0	25.6	28.1	25.9	26.9
GIVE DISADVANTAGED PREF TRTMNT	37.3	33.0	37.3	34.6	42.2	39.0	40.7	37.2	33.6	35.1	71.0	60.0	65.1
COL TOO LAX ON STUDENT PROTEST	32.3	41.5	33.1	43.7	41.4	37.1	39.3	45.5	40.1	42.4	40.2	37.9	39.0
ADOPT OPEN ADMISSIONS AT PUB COL	25.6	31.8	33.4	40.1	33.4	35.0	34.2	39.9	39.0	39.4	51.4	48.3	49.7
USE SAME DEGREE STANDARD FOR ALL	77.0	75.9	74.5	74.9	78.0	76.6	77.3	75.4	75.3	75.3	74.9	70.9	72.8
CURRENT POLITICAL PREFERENCE													
FAR LEFT	6.1	3.0	5.0	2.0	6.6	4.4	5.5	3.2	1.5	2.3	6.6	6.5	6.6
LIBERAL	50.6	40.2	44.1	38.5	41.6	41.6	41.6	42.2	33.5	37.2	39.5	38.2	38.8
MIDDLE-OF-THE-ROAD	30.3	42.7	38.3	46.0	37.2	40.5	38.8	40.0	51.5	46.6	37.7	41.3	39.6
CONSERVATIVE	12.4	13.5	12.1	13.1	13.8	13.3	13.5	14.0	13.3	13.6	13.2	12.2	12.7
FAR RIGHT	.6	.6	.4	.4	.8	.4	.6	.6	.2	.3	2.9	1.8	2.3
OBJECTIVES CONSIDERED TO BE ESSENTIAL OR VERY IMPORTANT													
ACHIEVE IN A PERFORMING ART	15.6	9.9	26.3	18.2	14.0	19.6	16.8	11.9	13.8	13.0	15.8	17.3	16.6
BE AN AUTHORITY IN MY FIELD	63.1	62.0	61.7	57.7	63.6	55.3	59.5	67.2	54.0	59.6	73.0	71.8	72.4
OBTAIN RECOGNITION FROM PEERS	41.5	41.8	40.5	35.2	42.2	32.2	37.3	46.0	33.9	39.1	58.5	51.3	54.6
INFLUENCE POLITICAL STRUCTURE	27.0	21.3	19.3	15.7	23.6	14.7	19.2	22.1	12.4	16.6	27.6	17.9	22.4
INFLUENCE SOCIAL VALUES	35.2	36.4	35.9	35.8	33.6	35.6	34.6	35.9	35.4	35.6	38.0	36.9	37.4
RAISE A FAMILY	57.6	61.3	59.9	65.5	57.0	62.0	59.4	61.1	69.3	65.8	53.2	54.7	54.0
HAVE ACTIVE SOCIAL LIFE	49.3	58.7	49.2	53.2	55.3	47.5	51.5	61.2	55.2	57.8	62.0	52.4	56.8
HAVE FRIENDS DIFFERENT FROM ME	62.4	65.8	66.5	67.5	59.5	65.1	62.2	65.0	70.7	68.3	54.2	55.3	54.8
BE AN EXPERT IN FINANCE	12.1	16.2	6.0	6.8	16.4	5.3	10.9	21.7	5.7	12.6	30.4	19.4	24.5
BE ADMINISTRATIVELY RESPONSIBLE	17.1	21.9	11.4	13.5	23.3	10.6	17.1	26.1	13.4	18.8	34.9	25.9	30.0
BE VERY WELL-OFF FINANCIALLY	35.9	42.3	30.4	25.7	44.5	22.4	33.7	47.1	24.0	33.8	65.0	51.4	57.7
HELP OTHERS IN DIFFICULTY	63.4	68.5	71.3	77.7	61.7	74.0	67.8	64.5	79.5	73.2	66.5	74.2	70.6
PARTICIPATE IN PEACE CORPS/VISTA	18.5	17.9	24.4	25.0	14.2	25.1	19.6	15.7	27.0	22.2	13.9	19.1	16.7
BECOME A COMMUNITY LEADER	20.2	16.8	13.2	11.5	18.7	11.0	14.9	20.6	9.7	14.3	32.1	23.2	27.3
CONTRIBUTE TO SCIENTIFIC THEORY	13.5	10.1	7.7	7.2	12.2	6.7	9.5	13.5	7.3	9.9	14.4	9.4	11.7
WRITE ORIGINAL WORKS	22.5	15.1	24.3	17.6	17.4	21.4	19.4	13.7	15.5	14.7	13.8	15.0	14.4
NEVER BE OBLIGATED TO PEOPLE	20.5	18.0	21.1	17.9	22.6	20.2	21.4	18.8	16.5	17.5	29.2	29.0	29.1
CREATE WORKS OF ART	16.9	10.6	30.8	22.9	14.0	24.7	19.3	10.4	19.9	15.9	13.9	13.0	13.4
KEEP UP WITH POLITICAL AFFAIRS	58.5	54.8	55.7	49.1	50.0	45.2	47.6	54.3	47.0	50.1	49.0	40.9	44.6
SUCCEED IN MY OWN BUSINESS	39.7	46.9	31.3	30.1	49.7	25.1	37.6	52.7	26.2	37.4	64.8	46.8	55.1
HELP CLEAN UP ENVIRONMENT	48.4	43.6	46.3	43.6	46.3	43.7	45.0	45.6	40.9	42.9	41.7	38.3	39.9
DEVELOP A PHILOSOPHY OF LIFE	79.7	76.2	80.7	79.1	71.9	79.7	75.8	72.9	80.4	77.2	66.1	68.8	67.6
PARTICIPATE IN COMMUNITY ACTION	29.7	31.2	35.1	32.7	26.4	32.5	29.4	29.5	33.1	31.6	41.3	40.9	41.1
MARRY WITHIN NEXT 5 YEARS	15.9	21.5	27.1	30.3	19.8	29.6	24.6	20.4	30.5	26.2	23.2	37.2	30.8

AMERICAN COUNCIL ON EDUCATION
OFFICE OF RESEARCH FALL 1971
WEIGHTED NATIONAL NORMS

	Colleges for Men		Colleges for Women		Coeducational Colleges						Predominantly Black Colleges		
	Nonsect.	Catholic	Nonsect.	Catholic	Nonsectarian			Catholic			Men	Women	Total
					Men	Women	Total	Men	Women	Total			
SELF RATINGS OF BETTER THAN 'AVERAGE' ON PERSONAL TRAITS													
ACADEMIC ABILITY	84.2	57.4	68.6	57.5	57.6	62.1	59.8	54.2	52.1	53.0	25.2	26.6	26.0
ATHLETIC ABILITY	48.8	40.7	32.9	28.1	47.4	24.4	36.1	45.4	24.1	33.3	45.3	16.3	29.9
ARTISTIC ABILITY	21.4	14.8	29.0	22.0	19.0	23.6	21.3	14.6	18.3	16.7	14.3	10.4	12.2
CHEERFULNESS	51.3	51.3	56.8	56.5	48.8	56.3	52.5	49.9	57.1	54.0	50.1	60.3	55.5
DEFENSIVENESS	27.3	26.0	28.8	28.0	25.7	26.1	25.9	26.8	27.7	27.3	29.3	26.0	27.6
DRIVE TO ACHIEVE	70.6	54.4	64.8	58.7	53.8	58.3	56.0	51.7	56.4	54.4	56.6	60.0	58.4
LEADERSHIP ABILITY	55.8	38.8	43.3	36.4	42.9	36.0	39.5	39.5	31.6	35.0	38.4	29.0	33.4
MATHEMATICAL ABILITY	65.3	34.5	29.8	27.6	38.9	29.2	34.1	33.4	27.6	30.1	17.4	12.1	14.6
MECHANICAL ABILITY	27.7	20.3	14.2	11.6	30.0	10.0	20.2	25.9	8.7	16.2	18.2	4.0	10.7
ORIGINALITY	50.6	35.9	51.6	37.9	42.5	41.2	41.8	35.7	34.4	35.0	26.6	29.0	27.9
POLITICAL CONSERVATISM	13.2	10.6	9.6	7.3	11.0	7.3	9.2	10.5	7.2	8.6	7.7	4.1	5.8
POLITICAL LIBERALISM	44.9	28.9	32.8	24.5	33.4	28.6	31.0	31.4	20.3	25.1	20.1	16.3	18.1
POPULARITY (GENERAL)	41.9	33.9	35.2	27.9	33.8	27.8	30.9	33.9	25.8	29.3	31.9	27.8	29.7
POPULARITY WITH OPPOSITE SEX	38.6	28.4	33.9	23.9	31.7	25.9	28.8	31.1	20.1	24.9	39.4	28.5	33.6
PUBLIC SPEAKING ABILITY	36.9	21.8	26.9	22.1	27.2	21.8	24.6	23.1	17.2	19.7	20.4	19.3	19.8
SELF-CONFIDENCE (INTELLECTUAL)	59.7	39.2	43.6	37.2	44.5	38.9	41.8	43.5	31.5	36.7	39.2	30.8	34.7
SELF-CONFIDENCE (SOCIAL)	35.6	29.9	34.6	27.0	32.0	27.9	30.0	33.7	23.7	28.0	36.5	30.1	33.1
SENSITIVITY TO CRITICISM	34.1	27.7	35.0	29.9	25.7	32.3	28.9	26.5	29.1	28.0	17.3	17.9	17.6
STUBBORNNESS	40.3	38.2	40.9	37.9	35.6	37.7	36.6	37.0	38.1	37.6	19.1	24.7	22.1
UNDERSTANDING OF OTHERS	72.3	66.3	75.3	69.4	65.5	72.5	69.0	64.4	70.0	67.6	57.4	63.3	60.5
WRITING ABILITY	50.4	31.3	42.3	32.0	34.4	36.9	35.6	29.1	27.0	27.9	24.4	27.6	26.1
STUDENTS ESTIMATE CHANCES ARE VERY GOOD THAT THEY WILL													
GET MARRIED WHILE IN COLLEGE	4.1	5.5	7.2	8.3	6.2	9.1	7.6	6.3	7.2	6.8	6.5	9.5	8.1
MARRY WITHIN A YEAR AFTER COL	16.4	18.9	22.0	22.5	16.6	20.7	18.6	18.3	22.1	20.4	16.2	21.3	19.0
VOTE IN 1972 PRES ELECTION	83.7	81.1	81.9	80.1	77.2	77.9	77.6	80.1	82.8	81.6	67.5	66.7	67.1
ENLIST IN ARMED SERV BEFORE GRAD	.8	1.3	.3	1.1	1.2	.3	.8	.9	.7	.8	2.0	.9	1.4
CHANGE MAJOR FIELD	20.8	12.8	21.2	13.3	14.9	18.3	16.6	14.5	13.5	13.9	10.5	11.0	10.7
CHANGE CAREER CHOICE	24.0	13.4	23.0	13.6	16.0	19.6	17.8	14.2	14.3	14.3	8.1	9.6	8.9
FAIL ONE OR MORE COURSES	1.6	1.6	3.4	1.5	2.7	2.0	2.3	2.3	1.9	2.1	2.7	3.1	2.9
GRADUATE WITH HONORS	8.8	6.5	6.4	5.9	6.3	5.5	5.9	6.2	4.1	5.0	9.9	6.7	8.2
BE ELECTED TO A STUDENT OFFICE	2.9	1.8	2.0	1.8	2.4	1.6	2.0	2.9	1.1	1.9	5.0	3.7	4.3
JOIN SOC FRATERNITY OR SORORITY	21.2	17.9	17.6	15.2	15.4	19.4	17.3	14.5	19.7	17.4	18.3	22.2	20.4
BE ELECTED TO AN HONOR SOCIETY	6.0	4.3	5.3	4.7	4.1	4.6	4.3	3.7	3.8	3.8	4.4	4.9	4.6
MAKE AT LEAST A 'B' AVERAGE	37.9	29.9	30.9	29.6	26.4	29.9	28.1	29.1	27.1	28.0	16.5	17.7	17.1
NEED EXTRA TIME TO GET DEGREE	2.1	3.2	2.9	4.0	3.7	3.2	3.5	4.0	3.9	4.0	5.7	6.2	5.9
WORK AT OUTSIDE JOB	24.0	35.9	23.3	34.0	27.6	29.1	28.4	38.2	38.9	38.6	23.6	23.0	23.3
SEEK VOCATIONAL COUNSELING	15.4	18.2	17.3	15.3	11.4	13.9	12.6	16.9	15.7	16.2	12.6	14.5	13.6
SEEK PERSONAL COUNSELING	9.7	10.2	11.0	9.0	8.2	8.4	8.3	11.6	8.6	9.8	11.3	11.5	11.4
ENROLL IN HONORS COURSE	18.4	6.2	12.9	8.5	7.3	8.5	7.9	6.9	7.2	7.1	5.0	6.4	5.8
GET TUTORING HELP IN COURSES	7.0	8.6	10.2	7.9	8.9	9.4	9.1	6.5	7.9	7.3	15.9	18.9	17.5
AUTHOR A PUBLISHED ARTICLE	9.7	5.3	8.6	4.7	7.4	6.3	6.9	5.3	3.8	4.4	5.5	4.2	4.8
BE MORE SUCCESSFUL THAN MOST	10.8	9.0	7.7	6.3	12.2	5.2	8.8	13.6	4.4	8.3	18.2	11.4	14.6
DROP OUT TEMPORARILY	2.8	1.1	2.8	2.4	2.2	2.6	2.4	1.3	1.5	1.4	1.6	1.2	1.4
DROP OUT PERMANENTLY	.4	.6	.9	1.5	.8	1.6	1.2	1.1	.9	1.0	1.1	.9	1.0
TRANSFER TO ANOTHER COLLEGE	5.3	8.5	17.2	12.7	9.6	11.9	10.7	12.8	12.0	12.3	7.3	8.4	7.9
BE SATISFIED WITH MY COLLEGE	63.3	58.2	55.3	61.4	54.5	61.5	57.9	51.8	59.8	56.4	55.4	58.0	56.8

AMERICAN COUNCIL ON EDUCATION
OFFICE OF RESEARCH FALL 1971
WEIGHTED NATIONAL NORMS

	Colleges for Men		Colleges for Women		Coeducational Colleges						Predominantly Black Colleges		
					Nonsectarian			Catholic					
	Nonsect.	Catholic	Nonsect.	Catholic	Men	Women	Total	Men	Women	Total	Men	Women	Total
ACTIVITIES ENGAGED IN BY STUDENTS DURING THE PAST YEAR													
VOTED IN STUDENT ELECTION (3)	64.2	68.9	68.9	69.3	62.1	66.0	64.0	66.0	71.9	69.4	68.3	73.0	70.8
CAME LATE TO CLASS	63.3	54.2	62.3	50.0	60.4	58.6	59.5	51.1	48.4	49.6	64.8	60.7	62.6
PLAYED A MUSICAL INSTRUMENT	44.1	35.6	51.9	45.3	41.6	48.0	44.8	33.4	39.8	37.0	35.5	33.6	34.5
STUDIED IN THE LIBRARY (3)	36.5	30.8	41.5	41.2	29.3	37.6	33.4	28.6	37.2	33.5	34.9	45.0	40.3
CHECKED OUT A LIBRARY BOOK (3)	48.3	37.3	57.3	52.0	39.3	53.5	46.3	32.5	51.0	43.0	38.0	56.1	47.7
ARRANGED DATE FOR STUDENT	36.2	44.4	38.8	38.9	42.3	35.8	39.1	44.5	42.4	43.3	47.5	33.0	39.7
OVERSLEPT AND MISSED A CLASS	28.2	22.8	25.1	17.5	29.0	22.6	25.8	23.8	17.3	20.1	28.9	19.8	24.0
READ ABOUT RIGHTS/RESPONSIBILITY	74.4	67.1	79.0	70.0	68.9	73.8	71.3	65.1	72.9	69.6	75.1	79.7	77.5
TYPED A HOMEWORK ASSIGNMENT (3)	25.1	21.5	34.6	30.4	17.9	28.7	23.2	21.0	31.2	26.8	15.2	32.9	24.6
DISCUSSED FUTURE WITH PARENTS(3)	36.7	38.8	50.8	47.6	35.5	48.4	41.8	33.9	48.8	42.3	38.2	46.5	42.6
WAS LATE WITH SCHOOL ASSIGNMENT	69.7	68.6	62.3	60.0	74.6	65.7	70.2	70.5	58.8	63.9	71.9	61.0	66.1
ARGUED WITH A TEACHER IN CLASS	70.5	56.0	56.2	47.6	60.7	51.6	56.2	60.0	43.5	50.6	36.3	28.0	31.9
ATTENDED A RELIGIOUS SERVICE	80.6	93.5	84.4	93.3	80.6	85.3	82.9	91.8	95.0	93.6	88.2	93.4	91.0
DEMONSTRATED FOR RACIAL CHANGE	25.1	19.7	27.7	16.4	25.9	23.1	24.5	20.3	14.7	17.1	44.2	36.9	40.3
DEMONSTRATED FOR MILITARY CHANGE	26.8	15.0	21.6	12.3	22.5	18.6	20.6	15.9	9.9	12.5	14.8	8.9	11.7
DEMONSTRATED FOR SCHOOL CHANGE	43.0	40.6	47.1	36.8	42.3	40.3	41.3	43.1	37.2	39.8	52.2	48.8	50.4
DID EXTRA READING FOR COURSE (3)	21.8	14.0	26.9	20.6	16.0	22.4	19.1	13.1	17.6	15.7	18.2	23.2	20.9
TOOK SLEEPING PILLS	4.3	3.6	7.1	4.7	4.2	5.7	4.9	3.8	4.5	4.2	1.9	4.0	3.0
TUTORED ANOTHER STUDENT	63.7	52.1	58.4	54.5	46.1	55.1	50.5	45.1	56.3	51.5	42.9	48.5	45.9
PLAYED CHESS	50.8	45.9	25.9	28.5	54.1	25.9	40.2	51.5	25.9	37.0	28.6	11.1	19.2
READ POETRY NOT REQUIRED	65.5	56.0	82.5	78.7	54.9	81.0	67.7	48.7	78.5	65.6	62.3	74.8	69.0
TOOK A TRANQUILIZING PILL	4.7	4.7	10.3	7.9	5.6	9.3	7.4	4.6	7.4	6.2	2.8	5.4	4.2
DISCUSSED RELIGION (3)	28.9	30.7	36.2	40.2	26.9	39.3	33.0	27.3	36.1	32.3	18.5	24.3	21.6
TOOK VITAMINS	60.4	57.3	69.5	62.1	58.7	67.8	63.2	56.8	64.6	61.2	54.8	57.3	56.1
VISITED ART GALLERY OR MUSEUM	77.9	65.4	85.4	75.8	67.5	76.6	71.9	62.4	76.1	70.2	62.3	63.4	62.9
PARTICIPATED IN H.S. POL. CMPG.	44.0	44.6	47.1	45.6	38.6	40.2	39.3	41.7	47.0	44.7	47.6	54.3	51.1
PARTICIPATED IN OTHER POL.CMPG.	23.7	20.2	26.9	19.5	17.3	19.3	18.3	14.7	17.7	16.4	14.6	18.0	16.4
MISSED SCHOOL DUE TO ILLNESS (3)	2.9	2.7	6.3	3.8	2.5	6.4	4.4	2.0	3.4	2.8	2.7	5.6	4.3
SMOKED CIGARETTES (3)	9.5	16.6	16.9	15.5	16.1	13.2	14.7	20.4	15.3	17.5	13.7	8.4	10.9
DISCUSSED POLITICS (3)	41.2	30.4	31.0	23.2	30.7	23.8	27.3	27.2	20.1	23.2	20.1	15.1	17.4
DRANK BEER	66.7	76.1	51.5	59.3	66.5	40.4	53.7	79.2	58.8	67.6	60.6	36.9	47.9
DISCUSSED SPORTS (3)	46.8	53.4	24.4	29.9	53.0	24.1	38.8	57.4	26.4	39.8	67.7	29.2	47.1
READ ABOUT CIVIL RIGHTS	87.8	83.2	85.5	83.5	83.1	84.6	83.8	82.8	84.4	83.7	92.4	92.5	92.5
ASKED TEACHER FOR ADVICE (3)	33.1	23.8	36.4	27.2	25.4	29.7	27.5	25.9	25.8	25.8	32.4	33.9	33.2
HAD VOCATIONAL COUNSELING	30.6	55.6	40.4	54.7	40.9	40.6	40.8	52.6	55.0	54.0	55.7	58.6	57.2
STAYED UP ALL NIGHT	58.7	59.3	64.7	59.6	61.6	63.0	62.3	61.0	62.6	61.9	59.4	53.0	55.9

(**) THIS ITEM IS REPORTED FOR THE FIRST TIME IN 1971. ITEMS NOT INDICATED WITH '**' ARE REPEATED OR MODIFIED QUESTIONS FROM ONE OR MORE OF THE EARLIER SURVEYS.

(1) SINCE IT IS POSSIBLE THAT SOME STUDENTS MAY HAVE CHECKED MORE THAN ONE RESPONSE CATEGORY FOR THIS ITEM, THE PERCENTAGES MAY SUM TO MORE THAN 100.

(2) RECATEGORIZATION OF THIS ITEM FROM A LONGER LIST IS SHOWN IN APPENDIX C OF THE 1971 NAT'L NORMS REPORT.

(3) FREQUENTLY ONLY, ALL OTHER ITEMS FREQUENTLY PLUS OCCASIONALLY.

APPENDIX A

Institutions Participating in the ACE
Cooperative Institutional Research Program



INSTITUTIONS PARTICIPATING IN THE ACE
COOPERATIVE INSTITUTIONAL RESEARCH PROGRAM^a

<u>Institution</u>	<u>Strati- fication Cell</u>	<u>Number of Years Institution Participated</u>	<u>1971</u>
Abilene Christian College (TX)	12	3	
Academy of Aeronautics (NY)	32	5	X
Adelphi University-Main Campus (NY)	04	6	X*
Adrian College (MI)	21	6	X
Alabama A&M College (AL)	34	6	X
Alabama State University (AL)	34	2	X*
Alfred University (Main Campus) (NY)	12	6	X
Allegheny College (PA)	12	6	X*
Alice Lloyd College (KY)	30	1	X*
American University (DC)	06	6	X
Amherst College (MA)	14	6	X*
Anderson College (SC)	32	2	X*
Andrews University (MI)	22	1	X
Appalachian State University (NC)	07	1	X*
Aquinas College (MI)	17	6	X*
Area XV Community College (IA)	27	5	
Arizona State University (AZ)	02	3	
Arkansas AM&N College (AK)	34	6	X
Athens College (AL)	20	6	X*
Atlantic Community College (NJ)	28	1	X
Augsburg College (MN)	23	6	X
Augustana College (IL)	23	2	X
Augustana College (SD)	22	3	X*
Austin College (TX)	23	6	X*
Austin Peay State University (TX)	07	2	X*
Averett College (VA)	20	6	X
Ball State University (IN)	01	2	
Baptist Bible Seminary (CO)	24	4	X*
Baptist College of Charleston (SC)	24	1	
Bard College (NY)	13	2	X*
Bates College (ME)	13	6	X*
Baylor University-Main Campus (TX)	05	6	X
Bay Path Junior College (MA)	31	6	X*
Beaver College (PA)	23	1	X*
Bee County Junior College (TX)	27	4	X*
Bellarmino-Ursuline College (KY)	16	6	X
Benedictine College ^b (KS)	16	5	X*

* These institutions have provided data judged to be representative of their first-time, full-time entering freshman class and are included in the norms.

^aInstitutions which had submitted 1971 data in time to be tabulated for this publication are indicated by an "X."

^bFormerly Mt. St. Scholastica.

<u>Institution</u>	<u>Strati- fication Cell</u>	<u>Number of Years Institution Participated</u>	<u>1971</u>
Beloit College (WI)	14	6	X*
Bennington College (VT)	14	6	X*
Berea College (KY)	11	6	X*
Bergen Community College (NJ)	28	3	X
Bethany Lutheran Col. & Theo. Sem. (MN)	24	6	X*
Black Hawk College (IL)	28	6	X
Bluffton College (OH)	21	1	X*
Boise College (ID)	10	1	
Boston College - Main Campus (MA)	06	3	
Bowdoin College (ME)	14	6	X*
Bowie State College (MD)	34	3	X*
Bradford Junior College (MA)	27	1	X*
Bradley University (IL)	04	6	X*
Brandeis University (MA)	06	5	X*
Brevard College (NC)	32	2	X*
Briarcliff College (NY)	11	6	X
Brigham Young University (UT)	04	1	X
Bryant Col. of Bus. Administration (MA)	15	1	
Buena Vista College (IA)	20	6	X*
California Institute of Technology (CA)	14	6	X*
California State College (PA)	07	3	
California State Col. - Fullerton (CA)	10	6	X
Calvin College (MI)	23	5	X
Cardinal Stritch College (WI)	17	6	X
Carleton College (MN)	14	6	X*
Carnegie-Mellon University (PA)	06	4	
Carroll College (WI)	23	6	X*
Carson Newman College (TN)	20	2	X*
Cascade College (OR)	11	1	
Case Western Reserve University (OH)	06	3	
Catholic University of America (DC)	06	1	X
Cazenovia College (NY)	32	3	X*
Central Methodist College (MO)	21	1	X*
Central Nebraska Tech (NB)	27	4	X*
Central State University (OH)	34	1	X
Centre College of Kentucky (KY)	13	1	X*
Centenary College for Women (NJ)	20	1	X*
Cerritos College (CA)	29	5	X
Champlain College (VT)	32	1	
Chapman College (CA)	12	6	X
Chatham College (PA)	16	6	X*
Chestnut Hill College (PA)	17	1	X*
Chicago State College (IL)	08	4	
Chowan College (NC)	33	3	X*
Citrus Junior College (CA)	29	5	X
City College of San Francisco (CA)	29	5	X
Claremont Men's College (CA)	14	5	X*
Clarendon College (TX)	26	3	
Clarion State College - Main Campus (PA)	09	5	
Clark County Technical Institute (OH)	27	4	X*
Coastal Carolina Regional Campus (SC)	26	1	X*

<u>Institution</u>	<u>Strati- fication Cell</u>	<u>Number of Years Institution Participated</u>	<u>1971</u>
Clark University (MA)	13	4	X
Cochise College (AZ)	27	3	
Colby College (ME)	13	6	X*
Colgate University (NY)	13	1	X*
College of Charleston (SC)	13	5	X*
College of Mt. St. Vincent (NY)	13	6	X*
College of New Rochelle (NY)	18	6	X
College of Notre Dame (CA)	17	6	X
Col. of Our Lady of the Elms (MA)	16	1	X*
College of St. Benedict (MN)	18	4	X*
College of St. Catherine (MN)	18	1	X*
College of St. Rose (NY)	17	1	X*
College of Santa Fe (NM)	19	2	
College of the Mainland (TX)	27	1	
College of the Sacred Heart (PR)	19	2	
College of the Sequoias (CA)	29	6	X*
Colorado State University (CO)	01	2	
Columbia College (SC)	21	1	X*
Columbia University (NY)	06	3	
Community College of Delaware Co. (PA)	28	4	X*
Compton College (CA)	28	6	X
Concordia College - Moorhead (MN)	23	2	
Connecticut College (CT)	14	5	X*
Cornell Univ. - Human Ecology (NY)	04	2	
Corning Community College (NY)	28	1	
Cowley County Community Jr. College (KS)	27	6	X
CUNY - Baruch College (NY)	10	6	X
CUNY - Borough of Manhattan College (NY)	29	1	
CUNY - Bronx Community College (NY)	29	3	
CUNY - Brooklyn College (NY)	09	1	
CUNY - City College (NY)	09	6	X
CUNY - Hunter College (NY)	09	5	
CUNY - John Jay College (NY)	09	2	X*
CUNY - Lehman College (NY)	10	1	
CUNY - N.Y.C. Community College (NY)	29	3	
CUNY - Queens College (NY)	09	1	
CUNY - Queensborough College (NY)	29	1	
CUNY - Staten Island College (NY)	29	2	X
CUNY - York College (NY)	10	1	
Coppin State College (MD)	34	1	
Cottey College (MO)	31	1	X
Cullman College (AL)	30	2	X
Curry College (MA)	15	2	X
Dakota Wesleyan University (SD)	21	4	
Dallas Baptist College (TX)	24	3	
Daniel Payne College (AL)	35	1	
Dartmouth College (NH)	14	6	X*
David Lipscomb College (TN)	21	3	
Davidson College (NC)	23	1	X*
Davis and Elkins College (WV)	20	6	X*

<u>Institution</u>	<u>Strati- fication Cell</u>	<u>Number of Years Institution Participated</u>	<u>1971</u>
Defiance College (OH)	11	4	X*
Delaware State College (DE)	34	6	X*
Del. Valley Col. of Sci. & Agri. (PA)	11	6	X*
Denison University (OH)	12	1	X*
DePauw University (IN)	23	6	X*
Dickinson College (PA)	13	6	X*
Dillard University (LA)	35	3	
Dominican College of Blauvelt (NY)	19	6	X*
Dominican College of San Rafael (CA)	16	6	X*
Doane College (NB)	12	1	X*
Donnelly College (KS)	31	6	X
Dowling College (NY)	10	1	
Drake University (IA)	05	4	X*
Duke University (NC)	06	1	X
Dutchess Community College (NY)	28	5	X*
D'Youville College (NY)	17	2	X
Earlham College (IN)	23	6	X*
East Central State College (OK)	07	2	X*
Eastern Baptist College (PA)	21	1	X
Eastern Iowa Cmty. Col. - Muscatine (IA)	27	5	X*
Eastern Mennonite College (VA)	21	6	X*
Edmonds Community College (WA)	27	1	
Eisenhower College (NY)	15	2	X*
Elizabeth City State College (NC)	34	1	X*
Elizabethtown College (PA)	22	3	X*
Elko Community College (NV)	25	1	X
Elmira College (NY)	15	1	X
Elon College (NC)	21	1	X
Emory and Henry College (VA)	22	6	X*
Emory University (GA)	06	2	X
Erskine College (SC)	21	1	X*
Fairhaven Col. - W. Wash. St. Univ. (WA)	09	1	
Fairleigh Dickinson University (NJ)	11	2	X
Fairmont State College (WV)	07	4	X
Findlay College (OH)	20	1	X*
Fisk University (TN)	35	6	X*
Florida College (FL)	31	4	X*
Florida Keys Jr. College (FL)	26	3	
Florida Presbyterian College (FL)	24	2	X*
Florida State University (FL)	01	4	
Florida Technological University (FL)	10	4	X
Forest Park Community College (MO)	29	1	
Ft. Hays Kansas State College (KS)	07	5	
Ft. Lewis College (CO)	07	1	
Ft. Scott Community Jr. College (KS)	27	2	X*
Framingham State College (MA)	08	4	X*
Franklin and Marshall College (PA)	13	6	X*
Freed Hardeman College (TN)	32	5	X*
Fresno State College - Main Campus (CA)	08	4	
Gallaudet College (DC)	11	6	X

<u>Institution</u>	<u>Strati- fication Cell</u>	<u>Number of Years Institution Participated</u>	<u>1971</u>
Garden City Cmty Jr. College (KS)	27	2	X*
Garland Jr. College (MA)	31	2	X*
General Motors Institute (MI)	15	6	X*
Geneva College (PA)	21	1	X*
George Peabody Col. for Teachers (TN)	11	4	
George Williams College (IL)	11	6	X*
Georgia Inst. of Tech. - Main (GA)	09	6	X
Georgia Southwestern College (GA)	07	1	X*
Gettysburg College (PA)	23	6	X*
Glassboro State College (NJ)	08	1	
Gonzaga University (WA)	18	6	X
Grand Canyon College (AZ)	24	2	X*
Grand View College (IA)	32	4	X
Grayson County Jr. College (TX)	27	3	X*
Green River Community College (WA)	29	1	
Greenfield Community College (MA)	28	1	
Grinnell College (IA)	14	6	X
Guilford College (NC)	21	5	X*
Gulf Coast Junior College (FL)	28	2	X*
Gustavus Adolphus College (MN)	23	1	
Hamilton College (NY)	14	5	X
Hamline University (MN)	23	6	X*
Hampden Sydney College (VA)	23	2	X*
Hampton Institute (VA)	35	1	X*
Harding College - Main Campus (AR)	22	6	X*
Harris Teachers College (MO)	07	2	
Harrisburg Area Cmty. College (PA)	29	4	X
Harvard University (MA)	06	5	
Harvey Mudd College (CA)	14	4	
Haverford College (PA)	14	6	X*
Heidelberg College (OH)	22	1	X*
Henry Ford Community College (MI)	29	3	
Herkimer County Community College (NY)	27	4	X*
Highland Community College (IL)	27	5	X
Hiram College (OH)	13	2	X*
Hofstra University (NY)	12	1	X*
Hollins College (VA)	13	6	X
Holy Cross Junior College (IN)	31	1	
Hope College (MI)	13	1	X
Houston Baptist College (TX)	24	3	
Howard University (DC)	35	6	X
Humphreys College (CA)	30	4	X*
Huntington College (IN)	20	4	X
Huron College (SD)	20	3	X
Huston Tillotson College (TX)	35	1	
Idaho State University (ID)	08	5	
Illinois Central College (IL)	29	1	
Illinois Institute of Technology (IL)	13	5	
Immaculata College (IL)	31	2	

<u>Institution</u>	<u>Strati- fication Cell</u>	<u>Number of Years Institution Participated</u>	<u>1971</u>
Immaculate Heart College (CA)	18	5	X*
Indian River Jr. College (FL)	27	5	
Indiana University (IN)	02	1	
Iowa St. U. of Sci. & Tech. (IA)	03	3	X*
Iowa Wesleyan College (IA)	22	6	X*
Itasca State Junior College (MN)	27	5	
Ithaca College (NY)	12	1	X*
Jackson State College (MS)	34	1	X
Jamestown Community College (NY)	28	2	X
Jefferson Community College (NY)	28	4	X*
John Brown University (AK)	12	1	X*
John F. Kennedy College (NB)	15	1	
John Tyler Community College (VA)	28	2	
Johns Hopkins Univ. - Main Campus (MD)	06	6	X*
Johnson C. Smith University (NC)	35	6	X*
Junior College of St. Louis County (MO)	29	5	X
Kansas Wesleyan University (KS)	20	6	X*
Kentucky State College (KY)	34	6	X
Kentucky Wesleyan College (KY)	20	5	X
Keystone Junior College (PA)	32	6	X*
Kirkland College (NY)	15	4	X
Kishwaukee College (IL)	27	3	X
Knoxville College (TN)	35	3	
Kutztown College (PA)	09	1	
La Roche College (PA)	19	3	X
Lafayette College (PA)	23	4	X*
Lake City Junior College (FL)	27	4	X*
Lake Forest College (IL)	23	6	X*
Lakeland College (WI)	22	6	X*
Lakeland Community College (OH)	28	1	
Langston University (OK)	34	1	X
Laredo Junior College (TX)	27	5	X
Le Moyne College (NY)	18	6	X*
Lea College (MN)	15	1	
Lees College (KY)	31	1	X*
Lebanon Valley College (PA)	22	6	X*
Lenoir-Rhyne (NC)	21	1	X*
Lewis and Clark College (OR)	13	2	X*
Lewis and Clark Community College ^C (IL)	30	4	
Lincoln College (IL)	24	2	
Lincoln University (PA)	35	4	X*
Lindenwood College (MO)	22	5	X*
Lindfield College (OR)	22	1	X
Lock Haven State College (PA)	08	5	X*
Lone Mountain College (CA)	17	1	X
Longwood College (VA)	09	4	X*

^CFormerly Monticello College.

<u>Institution</u>	<u>Strati- fication Cell</u>	<u>Number of Years Institution Participated</u>	<u>1971</u>
Lorain Co. Community College (OH)	28	3	
Loretto Heights College (CO)	17	6	X*
Los Angeles Baptist Col. (CA)	24	6	X
Los Angeles City College (CA)	29	2	X
Louisiana Polytechnic Inst. (LA)	08	6	X
Louisiana State Univ.-Alexandria (LA)	27	3	X*
Louisiana State Univ.- Eunice (LA)	36	2	
Louisiana State Univ.-Baton Rouge (LA)	01	3	
Louisiana State Univ.-New Orleans (LA)	10	2	
Louisiana State Univ.-Shreveport (LA)	27	2	
Loyola University (IL)	05	4	X*
Loyola University (LA)	05	2	
Loyola University-Los Angeles (CA)	17	6	X
Luther College (IA)	23	2	X*
Macalester College (MN)	23	1	X
MacMurray College (IL)	22	6	X*
Madison College (VA)	09	1	X*
Madison Area Technical College (WI)	29	1	X*
Madonna College (MI)	16	6	X*
Manatee Junior College (FL)	28	3	X*
Manchester College (IN)	22	2	X*
Manhattan College (NY)	18	1	X*
Manhattanville College (NY)	18	3	
Marian College of Fond du Lac (WI)	16	6	X*
Marjorie Webster Junior College (DC)	31	1	X*
Marietta College (OH)	13	6	X*
Marlboro College (VT)	15	6	X*
Mars Hill College (NC)	20	1	X*
Mary Baldwin College (VA)	23	4	X
Mary Holmes Junior College (MS)	36	1	
Maryknoll Seminary (NY)	18	3	
Marymount College (KS)	16	6	X*
Marywood College (PA)	17	3	X*
McPherson College (KS)	23	6	X*
Medaille College (NY)	19	6	X*
Mercer Co. Community College (NJ)	29	5	X
Mercy College of Detroit (MI)	16	4	X*
Mercyhurst College (PA)	17	4	
Merrimack College (MA)	17	3	X*
Mesa College-Main Campus (CA)	29	3	
Metropolitan Junior College (MO)	27	4	X*
Miami University-Oxford Campus (OH)	02	6	X*
Michigan State University-Main (MI)	01	5	X
Middlebury College (VT)	14	6	X
Midway Junior College (KY)	30	4	X*
Milligan College (TN)	11	4	X*
Mills College (CA)	13	6	X
Millsaps College (MS)	22	4	X
Milton College (WI)	15	4	X

<u>Institution</u>	<u>Strati- fication Cell</u>	<u>Number of Years Institution Participated</u>	<u>1971</u>
Mississippi St. Col. for Women (MS)	08	1	X
Missouri Baptist College-Hannibal (MO)	31	5	X*
Missouri Baptist Col.-St. Louis (MO)	30	2	X
Mira Costa College (CA)	27	2	
Modesto Junior College (CA)	29	3	
Monmouth College (IL)	22	6	X*
Montana State University (MT)	02	6	X*
Montclair State College (NJ)	09	5	
Montgomery Co. Cmty. College (PA)	29	1	X*
Moorpark Junior College (CA)	28	4	X
Morehouse College (GA)	35	4	X
Morgan State College (MD)	34	3	X
Morningside College (IA)	23	3	X*
Morris Brown College (GA)	35	5	X*
Morris Harvey College (WV)	11	6	X
Morristown College (TN)	36	1	
Mount Holyoke College (MA)	14	6	X*
Mount Olive Junior College (NC)	31	3	X*
Mount St. Mary's College (MD)	16	4	X*
Mount St. Mary's College (NY)	19	1	X*
Mount San Antonio College (CA)	29	6	X
Mundelein College (IL)	13	1	
Napa College (CA)	28	2	
Nathaniel Hawthorne College (NH)	15	1	X*
National College of Education (IL)	11	6	X*
Nazareth College (MI)	11	6	X
Nazareth College of Rochester (NY)	18	6	X*
Newark College of Engineering (NJ)	09	6	X*
New Mexico State Univ.-Main (NM)	01	6	X
Newton College of the Sacred Heart (MA)	18	6	X
New York University (NY)	05	4	
Niagara Co. Community College (NY)	28	5	X
North Carolina A&T State College (NC)	34	2	X*
North Carolina Wesleyan College (NC)	24	4	X*
North Dakota State University (ND)	02	3	X*
North Greenville Junior College (SC)	32	5	
Northeastern Christian Jr. Col. (PA)	31	3	
Northeastern Junior College (CO)	28	1	X*
Northeastern University (MA)	04	6	X*
Northern Essex Cmty. College (MA)	28	1	
Northern Michigan University (MI)	07	1	X*
Northampton Co. Area Cmty. Col. (PA)	28	3	
Northland College (WI)	11	6	X*
Northwest Community College (WY)	27	1	
Northwest Missouri State College (MO)	08	5	
Northwestern University (IL)	06	6	X
Oakland City College (IN)	24	2	
Oakland University (MI)	10	5	
Oberlin College (OH)	14	4	

<u>Institution</u>	<u>Strati- fication Cell</u>	<u>Number of Years Institution Participated</u>	<u>1971</u>
Occidental College (CA)	14	6	X*
Ohio Dominican College (OH)	18	6	X*
Ohio Northern University (OH)	22	2	X
Ohio State University-Main Campus (OH)	01	4	
Ohio Technical College (OH)	15	4	X
Ohio University-Main Campus (OH)	01	3	X
Ohio University-Chillicothe (OH)	26	1	X*
Ohio University-Zanesville (OH)	26	1	X
Ohio Wesleyan University (OH)	23	1	X*
Oklahoma Christian College (OK)	15	4	X*
Oklahoma State University-Main (OK)	01	4	X*
Old Dominion University (VA)	08	1	X*
Oral Roberts University (OK)	15	1	
Orange Coast College (CA)	29	5	
Oregon State University (OR)	02	2	
Ottawa University (KS)	22	4	X*
Our Lady of the Lake College (TX)	16	6	X*
Pace College-Main Campus (NY)	11	5	X*
Packer Collegiate Institute (NY)	30	5	X*
Paducah Community College (KY)	28	3	
Park College (MO)	20	2	
Parsons College (IA)	11	6	X
Pennsylvania State Univ.-Allentown (PA)	25	4	
Pennsylvania State Univ.-Altoona (PA)	28	4	
Pennsylvania State Univ.-Beaver (PA)	27	4	
Pennsylvania State Univ.-Behrends (PA)	28	3	
Pennsylvania State Univ.-Berks (PA)	27	4	
Pennsylvania State Univ.-Capitol (PA)	06	3	
Pennsylvania State Univ.-Delaware (PA)	27	3	
Pennsylvania State Univ.-DuBois (PA)	27	4	
Pennsylvania State Univ.-Fayette (PA)	27	3	
Pennsylvania State Univ.-Hazleton (PA)	27	4	
Pennsylvania State U.-McKeesport (PA)	10	3	
Pennsylvania State U.-Mount Alto (PA)	27	4	
Pennsylvania St. U.-New Kensington (PA)	27	4	
Pennsylvania State U.-Ogontz (PA)	28	4	
Pennsylvania State U.-Schuylkill (PA)	27	4	
Pennsylvania State U.-Scranton (PA)	27	5	X*
Pennsylvania St. U.-Shenango Val. (PA)	27	4	
Pennsylvania State U.-Main (PA)	02	5	
Pennsylvania St. U.-Wilkes-Barre (PA)	26	5	X*
Pennsylvania State Univ.-York (PA)	26	4	
Pepperdine College (CA)	12	4	X*
Peru State College (NB)	07	5	X
Philadelphia College of Art (PA)	12	1	X*
Philadelphia College of Bible (PA)	15	3	X*
Philadelphia Col. of Phar. & Sci. (PA)	15	2	X*
Philadelphia Col. of Tex. & Sci. (PA)	11	1	X
Philander Smith College (AR)	35	4	X*
Pine Manor Junior College (MA)	32	4	X*

<u>Institution</u>	<u>Strati- fication Cell</u>	<u>Number of Years Institution Participated</u>	<u>1971</u>
Pitt Technical Institute (NC)	27	2	
Pitzer College (CA)	15	2	
Polytechnic Institute of Brooklyn (NY)	13	6	X*
Pomona College (CA)	14	3	
Prairie State College (IL)	27	5	X
Pratt Institute (NY)	04	5	X
Princeton University (NJ)	06	6	X*
Providence College (RI)	17	1	X*
Purdue University-Main (IN)	02	5	
Quinsigamond Community College (MA)	28	5	X*
Radcliffe College (MA)	14	4	
Rainey River State Jr. College (MN)	28	1	
Randolph Macon College (VA)	22	1	X*
Randolph Macon Woman's College (VA)	22	4	X*
Ranger College (TX)	26	5	X*
Reed College (OR)	14	5	X
Regis College for Women-Main (MA)	13	5	X*
Reinhardt College (GA)	31	2	X
Rensselaer Polytechnic Institute (NJ)	06	1	X*
Rhode Island College (RI)	08	6	X*
Rhode Island School of Design (RI)	13	3	
Rice University (TX)	06	1	X*
Ricks College (ID)	33	2	
Rider College (NJ)	11	6	X*
Rio Grande College (OH)	15	1	X
Rockford College (IL)	12	6	X*
Rockhurst College (MO)	17	5	X
Roger Williams College (RI)	15	4	X
Rollins College-Main Campus (FL)	12	5	
Russell Sage College (NY)	12	1	X*
Sacramento City College (CA)	29	1	
Saint Anselms College (NH)	16	1	X*
Saint Augustine College (NC)	35	1	X
Saint Benedict College (KS)	19	2	
Saint Edwards University (TX)	16	6	X*
Saint John College of Cleveland (OH)	17	6	X*
Saint John Fisher College, Inc. (NY)	17	6	X*
Saint John's College (NM)	15	1	X*
Saint Johns University (MN)	18	4	X*
Saint Joseph College-Main Campus (IN)	16	6	X*
Saint Joseph's College (PA)	17	1	X*
Saint Lawrence Seminary (WI)	30	4	
Saint Lawrence University (NY)	13	1	X*
Saint Louis University - Main (MO)	06	6	X
Saint Marys College (MI)	17	3	
Saint Marys College (CA)	16	6	X*
Saint Marys College of Md. (MD)	10	4	
Saint Mary's Dominican College (LA)	16	6	X*
Saint Meinrad College (IN)	17	6	X*
Saint Norbert College (WI)	17	6	X*
Saint Petersburg Junior College (FL)	29	1	

<u>Institution</u>	<u>Strati- fication Cell</u>	<u>Number of Years Institution Participated</u>	<u>1971</u>
Saint Pius X Seminary (NY)	31	1	
Saint Xavier College (IL)	18	3	X
Salem College (NC)	23	6	X*
Salisbury State College (MD)	08	1	X*
San Francisco Conservatory of Music	15	1	
San Jose City College (CA)	29	1	
San Luis Rey College (CA)	18	3	
Santa Barbara City College (CA)	29	3	
Sarah Lawrence College (NY)	14	1	X*
Schreiner Institute (TX)	31	2	X*
Scripps College (CA)	14	5	X
Seattle University (WA)	17	4	
Seton Hall University (PA)	04	1	X*
Shepherd College (WV)	08	2	X
Sienna College (NY)	16	1	X*
Simpson College (IA)	22	2	X*
Sinclair Community College (OH)	28	5	X*
South Carolina State College (SC)	34	1	X*
Southeastern Massachusetts Univ. (MA)	10	1	X*
Southern Colorado State College (CO)	08	2	
Southern Illinois Univ.-Main (IL)	01	5	X*
Southern Illinois Univ.-Edwardsville	10	2	X*
Southern Methodist University (TX)	06	6	X
Southern State College (AR)	07	3	X*
Southern State College (SD)	10	1	X*
Southwest Minnesota State Col. (MN)	10	4	X*
Spalding College (KY)	16	4	X*
Spelman College (GA)	35	4	X*
Spring Hill College (AL)	18	6	X*
Springfield College (MA)	11	6	X
Springfield College (IL)	31	4	X*
Stanford University (CA)	06	4	
Stanislaus State College (CA)	10	4	
Stephens College (MO)	11	6	X*
Stetson University (FL)	22	1	X*
Stevens Institute of Technology (NJ)	13	6	X*
Sullivan Co. Community College (NY)	28	1	
SUNY A&T-Alfred (NY)	29	5	X*
SUNY A&T-Cobleskill (NY)	29	3	X*
SUNY A&T-Delhi (NY)	29	6	X*
SUNY College-Brockport (NY)	08	5	X*
SUNY College-Cortland (NY)	07	5	X
SUNY College-Geneseo (NY)	09	5	X*
SUNY College-Oswego (NY)	09	6	X
SUNY College-Potsdam (NY)	09	3	
SUNY State Univ.-Stonybrook (NY)	09	5	X
Suomi College (MI)	31	3	X*
Susquehanna University (PA)	22	1	X*
Swarthmore College (PA)	14	6	X*

<u>Institution</u>	<u>Strati- fication Cell</u>	<u>Number of Years Institution Participated</u>	<u>1971</u>
Sweet Briar College (VA)	13	6	X*
Talladega College (AL)	35	6	X*
Tarkio College (MO)	21	5	
Tennessee State University (TN)	34	1	X*
Texas Christian University (TX)	04	6	X*
Texas Technological University (TX)	01	5	
T. A. Lawson State Jr. College (AL)	36	2	X*
Transylvania College (KY)	11	4	X*
Trinity College (DC)	18	6	X*
Tufts University (MA)	06	4	
Tulane University of La. (LA)	06	5	X
Tyler Junior College (TX)	29	2	
Union College (NB)	20	5	X*
U. S. Air Force Academy (CO)	09	5	X*
U. S. Coast Guard Academy (CT)	09	6	X*
U. S. Military Academy (NY)	09	6	X*
U. S. Naval Academy (MD)	09	2	X*
University of Akron (OH)	01	6	X
University of Alabama-Huntsville (AL)	01	2	X*
University of Alaska-Main (AK)	01	6	X
University of California-Berkeley (CA)	03	5	X
University of California - Davis (CA)	03	3	
University of California - Irvine (CA)	01	3	
Univ. of California - Los Angeles (CA)	03	5	
Univ. of California - Riverside (CA)	03	5	
Univ. of California - San Diego (CA)	03	3	
Univ. of Calif. - Santa Barbara (CA)	03	6	X*
Univ. of Calif. - Santa Cruz (CA)	03	5	X*
University of Colorado - Boulder (CO)	02	5	
Univ. of Colo. - Denver Center (CO)	01	1	
Univ. of Connecticut - Hartford (CT)	02	1	
Univ. of Connecticut - Main Campus (CT)	01	2	X
Univ. of Connecticut - Stamford (CT)	26	1	
Univ. of Connecticut - Torrington (CT)	26	1	
Univ. of Connecticut - Waterbury (CT)	27	1	
University of Dallas (TX)	19	5	
University of Dayton (OH)	18	1	X*
University of Delaware (DE)	01	6	X*
University of Denver (CO)	05	6	X
University of Detroit (MI)	04	5	
University of Georgia (GA)	01	4	
University of Hartford (CT)	11	4	
University of Idaho (ID)	01	2	
Univ. of Illinois - Main Campus (IL)	03	6	X*
University of Iowa (IA)	02	5	X
University of Kansas (KS)	02	6	X
University of Kentucky (KY)	01	4	
University of Louisville (KY)	02	5	X*
University of Maine - Augusta (ME)	27	2	X*

<u>Institution</u>	<u>Strati- fication Cell</u>	<u>Number of Years Institution Participated</u>	<u>1971</u>
University of Maine - Farmington (ME)	08	1	X*
University of Maine - Ft. Kent (ME)	10	1	X*
University of Maine - Machias ^d (ME)	10	4	X*
University of Maine - Orono (ME)	01	1	X
Univ. of Maine - Portland-Gorham (ME)	10	1	X
Univ. of Maine - Presque-Isle (ME)	10	1	X
Univ. of Massachusetts - Amherst (MA)	02	6	X*
University of Michigan (MI)	03	6	X
Univ. of Mississippi - Main Campus (MS)	01	4	
University of Missouri - Columbia (MO)	01	5	
Univ. of Missouri - Kansas City (MO)	01	5	X
University of Missouri - Rolla (MO)	10	4	
Univ. of Missouri - St. Louis (MO)	29	5	X*
Univ. of Nebraska - Main Campus (NB)	01	5	X
University of Nevada - Main Campus (NV)	01	1	
University of New Hampshire (NH)	01	4	
University of New Mexico (NM)	02	5	
Univ. of N. C. - Chapel Hill (NC)	03	6	X*
Univ. of North Dakota - Main Campus (ND)	02	5	X
University of Northern Colorado (CO)	09	2	
University of the Pacific (CA)	06	6	X
University of Pennsylvania (PA)	06	6	X
University of Pittsburgh - Bradford (PA)	26	1	
Univ. of Pittsburgh - Greensburg (PA)	26	1	
Univ. of Pittsburgh - Johnstown (PA)	28	1	
Univ. of Pittsburgh - Main Campus (PA)	02	1	
Univ. of Pittsburgh - Titusville (PA)	26	1	
Univ. of Puerto Rico - Rio Piedras (PR)	01	2	
University of Redlands (CA)	23	6	X*
University of Rhode Island (RI)	01	3	
University of Rochester (NY)	04	6	X*
Univ. of San Diego Col. for Men (CA)	18	4	
University of San Francisco (CA)	18	1	X*
Univ. of S. C. - Main Campus (SC)	01	6	X
University of Tampa (FL)	11	6	X
Univ. of Tennessee - Chattanooga (TN)	11	1	X*
Univ. of Tennessee - Knoxville (TN)	01	6	X
University of Toledo (OH)	01	1	X
University of Tulsa (OK)	05	6	X
University of Vermont (VT)	02	6	X
Univ. of Virginia - Charlottesville (VA)	03	5	
Univ. of Va. - George Mason Col. (VA)	10	2	X
University of Washington (WA)	03	2	
University of Wisconsin - Madison (WI)	03	1	

^d Formerly University of Maine - Washington State Campus.

<u>Institution</u>	<u>Strati- fication Cell</u>	<u>Number of Years Institution Participated</u>	<u>1971</u>
Univ. of Wisconsin - Milwaukee (WI)	01	2	X*
University of Wyoming (WY)	01	4	
Upsala College (NJ)	22	4	X*
Utah State University (UT)	01	2	
Utica Junior College (MS)	36	2	X*
Valparaiso University (IN)	23	6	X*
Vanderbilt University (TN)	06	6	X*
Vassar College (NY)	14	6	X
Vermont Technological College (VT)	27	1	
Victoria College (TX)	27	2	X*
Villa Maria College of Buffalo (NY)	31	5	X*
Virginia Commonwealth University (VA)	01	3	X
Virginia Military Institute (VA)	09	6	X*
Va. Polytechnic Inst. - Main Campus (VA)	01	6	X*
Virginia State Col. - Main Campus (VA)	34	5	X*
Virginia Union University (VA)	35	6	X*
Voorhees Technical Institute (SC)	31	1	
Walsh College (OH)	19	3	X*
Washburn University of Topeka (KS)	08	2	
Washington College (MD)	12	4	
Washington and Lee University (VA)	13	6	X*
Washington State University (WA)	02	5	
Washington University (MO)	06	4	X
Wayland Baptist College (TX)	20	5	X*
Wayne State University (MI)	01	1	X*
Waynesburg College (PA)	21	1	X*
Webb Inst. of Naval Architecture (NY)	14	6	X*
Webber College (FL)	15	1	X
Webster College (MO)	13	1	X*
Wellesley College (MA)	14	4	X*
Wentworth Institute (MA)	33	5	X*
Wesleyan College (GA)	22	3	
Wesleyan University (CT)	14	5	X*
West Chester State College (PA)	08	1	X*
West Virginia State College (WV)	07	4	
Western Carolina University (NC)	07	3	X
Western Illinois University (IL)	08	6	X*
Western New England College (MA)	15	6	X*
Western Washington St. Univ. (WA)	09	1	X
Western Wyoming Community College (WY)	26	4	X
Westminster College (MO)	23	2	
Westminster College (PA)	22	1	X*
Wharton County Junior College (TX)	28	4	X*
Wheaton College (MA)	13	6	X*
Whitman College (WA)	14	6	X*
William Carey College (MS)	20	6	X
Williams College (MA)	14	6	X*
Williamsport Area Cmty. College (PA)	29	3	X
Windham College (VT)	15	2	

<u>Institution</u>	<u>Strati- fication Cell</u>	<u>Number of Years Institution Participated</u>	<u>1971</u>
Wingate College (NC)	33	5	X*
Winston-Salem State College (NC)	34	5	X*
Wisconsin St. Univ. - La Crosse (WI)	08	5	
Wisconsin St. Univ. - Whitewater (WI)	09	5	X*
Wittenberg University (OH)	23	6	X*
Wofford College (SC)	21	6	X*
Wooster Junior College (MA)	32	6	X
Worthington State College (MN)	27	4	X*
Xavier University (OH)	17	2	X*
Yale University (CT)	06	1	X
Yankton College (SD)	11	6	X*
Yuba College (CA)	28	3	X



APPENDIX B

1971 Student Information Form



1971 STUDENT INFORMATION FORM

YOUR NAME (please print) First Middle or Maiden Last
HOME STREET ADDRESS (print)
CITY (print) STATE (print) Zip Code (if known)

191944

When were you born?

Month (01-12) Day (01-31) Year

Dear Student:

The information in this report is being collected as part of a continuing study of higher education by the American Council on Education. The Council, which is a non-governmental association of colleges and educational organizations, encourages and solicits your cooperation in this research in order to achieve a better understanding of how students are affected by their college experiences.

Sincerely yours,

Logan Wilson, President

Grid for optical mark reader with numbers 0-9 and a GRP. column.

DIRECTIONS: Your responses will be read by an optical mark reader. Your careful observance of these few simple rules will be most appreciated:

- Use only black lead pencil (No. 2 1/2 or less).
Make heavy black marks that fill the circle.
Erase cleanly any answer you wish to change.
Make no stray markings of any kind.

Yes No

EXAMPLE: Will marks made with ball pen or fountain pen be properly read? [circles]

1. Your Sex: Male Female
2. Are you presently married? Yes No

3. How old will you be on December 31 of this year? (Mark one)
4. What was your average grade in secondary school? (Mark one)

5. Where did you rank academically in your high school graduating class? (Mark one)
Top Quarter 3rd Quarter
2nd Quarter 4th Quarter

6. Did you graduate from secondary school in the class of 1971?
Yes No

7. Are you a veteran? (Mark one)
No
Yes, I served in Southeast Asia
Yes, but I did not serve in Southeast Asia

8. Mark one: This is the first time I have enrolled in college as a freshman
I have attended this college before
I came to this college from a junior college
I came to this college from a four-year college or university

9. The following questions deal with accomplishments that might possibly apply to your high school years. Do not be discouraged by this list; it covers many areas of interest and few students will be able to say "yes" to many items. (Mark all that apply)

10. What is the highest academic degree that you intend to obtain? (Mark one)
None
Associate (A.A. or equivalent)
Bachelor's degree (B.A., B.S., etc.)
Master's degree (M.A., M.S., etc.)
Ph.D. or Ed.D.
M.D., D.O., D.D.S., or D.V.M.
LL.B. or J.D. (Law)
B.D. (Divinity)
Other

11. How many miles is this college from your home? (Mark one)
5 or less
6-10
11-50
51-100
101-500
More than 500

12. What is the highest level of formal education obtained by your parents? (Mark one in each column)
Father Mother
Grammar school or less
Some high school
High school graduate
Some college
College degree
Postgraduate degree

13. Do you have any concern about your ability to finance your college education? (Mark one)
None (I am confident that I will have sufficient funds)
Some concern (but I will probably have enough funds)
Major concern (not sure I will be able to complete college)

14. For each item indicate if it is a source for financing your education. (Mark one in each row)
- | | | | |
|--------------------------------------------------------|-----------------------|-----------------------|-----------------------|
| Part-time or summer work | <input type="radio"/> | <input type="radio"/> | <input type="radio"/> |
| Savings from full-time employment | <input type="radio"/> | <input type="radio"/> | <input type="radio"/> |
| Parental or family aid or gifts | <input type="radio"/> | <input type="radio"/> | <input type="radio"/> |
| Federal benefits from <u>parent's</u> military service | <input type="radio"/> | <input type="radio"/> | <input type="radio"/> |
| G.I. benefits from <u>your</u> military service | <input type="radio"/> | <input type="radio"/> | <input type="radio"/> |
| Scholarships and grants | <input type="radio"/> | <input type="radio"/> | <input type="radio"/> |
| NDEA loans, federally insured loans or college loans | <input type="radio"/> | <input type="radio"/> | <input type="radio"/> |
| Other repayable loans | <input type="radio"/> | <input type="radio"/> | <input type="radio"/> |

Major Source
Minor Source
Not a Source

15. What is your best estimate of the total income last year of your parental family (not your own family if you are married)? Consider annual income from all sources before taxes. (Mark one)
- | | | | |
|-------------------|-----------------------|-------------------|-----------------------|
| Less than \$4,000 | <input type="radio"/> | \$15,000-\$19,999 | <input type="radio"/> |
| \$4,000-\$5,999 | <input type="radio"/> | \$20,000-\$24,999 | <input type="radio"/> |
| \$6,000-\$7,999 | <input type="radio"/> | \$25,000-\$29,999 | <input type="radio"/> |
| \$8,000-\$9,999 | <input type="radio"/> | \$30,000-\$34,999 | <input type="radio"/> |
| \$10,000-\$12,499 | <input type="radio"/> | \$35,000-\$39,999 | <input type="radio"/> |
| \$12,500-\$14,999 | <input type="radio"/> | \$40,000 or more | <input type="radio"/> |

16. Are you: (Mark all that apply.)
- | | |
|---------------------------|-----------------------|
| White/Caucasian | <input type="radio"/> |
| Black/Negro/Afro-American | <input type="radio"/> |
| American Indian | <input type="radio"/> |
| Oriental | <input type="radio"/> |
| Mexican-American/Chicano | <input type="radio"/> |
| Puerto Rican-American | <input type="radio"/> |
| Other | <input type="radio"/> |

17. Mark one in each column:
- | | Religion in Which You Were Reared | Your Present Religious Preference |
|----------------|-----------------------------------|-----------------------------------|
| Protestant | <input type="radio"/> | <input type="radio"/> |
| Roman Catholic | <input type="radio"/> | <input type="radio"/> |
| Jewish | <input type="radio"/> | <input type="radio"/> |
| Other | <input type="radio"/> | <input type="radio"/> |
| None | <input type="radio"/> | <input type="radio"/> |

18. In deciding to go to college, how important to you was each of the following reasons? (Mark one answer for each reason)
- | | | | |
|-------------------------------------------------------|----------------------------------|-----------------------|-----------------------|
| My parents wanted me to go | <input checked="" type="radio"/> | <input type="radio"/> | <input type="radio"/> |
| To be able to contribute more to my community | <input checked="" type="radio"/> | <input type="radio"/> | <input type="radio"/> |
| To be able to get a better job | <input checked="" type="radio"/> | <input type="radio"/> | <input type="radio"/> |
| To gain a general education and appreciation of ideas | <input checked="" type="radio"/> | <input type="radio"/> | <input type="radio"/> |
| To improve my reading and study skills | <input checked="" type="radio"/> | <input type="radio"/> | <input type="radio"/> |
| There was nothing better to do | <input checked="" type="radio"/> | <input type="radio"/> | <input type="radio"/> |
| To make me a more cultured person | <input checked="" type="radio"/> | <input type="radio"/> | <input type="radio"/> |
| To be able to make more money | <input checked="" type="radio"/> | <input type="radio"/> | <input type="radio"/> |
| To learn more about things that interest me | <input checked="" type="radio"/> | <input type="radio"/> | <input type="radio"/> |
| To meet new and interesting people | <input checked="" type="radio"/> | <input type="radio"/> | <input type="radio"/> |
| To prepare myself for graduate or professional school | <input checked="" type="radio"/> | <input type="radio"/> | <input type="radio"/> |

Very important
Somewhat important
Not important

19. Below is a general list of things that students sometimes do. Indicate which of these things you did during the past year in school. If you engaged in an activity frequently, mark **F**. If you engaged in an activity one or more times, but not frequently, mark **O** (occasionally). Mark **N** (not at all) if you have not performed the activity during the past year. (Mark one for each item)
- | | | | |
|---------------------------------------------------------------------------|-----------------------|-----------------------|-----------------------|
| Voted in a student election | <input type="radio"/> | <input type="radio"/> | <input type="radio"/> |
| Came late to class | <input type="radio"/> | <input type="radio"/> | <input type="radio"/> |
| Played a musical instrument | <input type="radio"/> | <input type="radio"/> | <input type="radio"/> |
| Studied in the library | <input type="radio"/> | <input type="radio"/> | <input type="radio"/> |
| Checked out a book or journal from the school library | <input type="radio"/> | <input type="radio"/> | <input type="radio"/> |
| Arranged a date for another student | <input type="radio"/> | <input type="radio"/> | <input type="radio"/> |
| Overslept and missed a class or appointment | <input type="radio"/> | <input type="radio"/> | <input type="radio"/> |
| Read about collegiate rights and responsibilities of students | <input type="radio"/> | <input type="radio"/> | <input type="radio"/> |
| Typed a homework assignment | <input type="radio"/> | <input type="radio"/> | <input type="radio"/> |
| Discussed my future with my parents | <input type="radio"/> | <input type="radio"/> | <input type="radio"/> |
| Failed to complete a homework assignment on time | <input type="radio"/> | <input type="radio"/> | <input type="radio"/> |
| Argued with a teacher in class | <input type="radio"/> | <input type="radio"/> | <input type="radio"/> |
| Attended a religious service | <input type="radio"/> | <input type="radio"/> | <input type="radio"/> |
| Demonstrated for a change in some racial or ethnic policy | <input type="radio"/> | <input type="radio"/> | <input type="radio"/> |
| Demonstrated for a change in some military policy | <input type="radio"/> | <input type="radio"/> | <input type="radio"/> |
| Demonstrated for a change in some administrative policy of my high school | <input type="radio"/> | <input type="radio"/> | <input type="radio"/> |
| Did extra (unassigned) reading for a course | <input type="radio"/> | <input type="radio"/> | <input type="radio"/> |
| Took sleeping pills | <input type="radio"/> | <input type="radio"/> | <input type="radio"/> |
| Tutored another student | <input type="radio"/> | <input type="radio"/> | <input type="radio"/> |
| Played chess | <input type="radio"/> | <input type="radio"/> | <input type="radio"/> |
| Read poetry not connected with a course | <input type="radio"/> | <input type="radio"/> | <input type="radio"/> |
| Took a tranquilizing pill | <input type="radio"/> | <input type="radio"/> | <input type="radio"/> |
| Discussed religion | <input type="radio"/> | <input type="radio"/> | <input type="radio"/> |
| Took vitamins | <input type="radio"/> | <input type="radio"/> | <input type="radio"/> |
| Visited an art gallery or museum | <input type="radio"/> | <input type="radio"/> | <input type="radio"/> |
| Worked in a school political campaign | <input type="radio"/> | <input type="radio"/> | <input type="radio"/> |
| Worked in a local, state, or national political campaign | <input type="radio"/> | <input type="radio"/> | <input type="radio"/> |
| Missed school because of illness | <input type="radio"/> | <input type="radio"/> | <input type="radio"/> |
| Smoked cigarettes | <input type="radio"/> | <input type="radio"/> | <input type="radio"/> |
| Discussed politics | <input type="radio"/> | <input type="radio"/> | <input type="radio"/> |
| Drank beer | <input type="radio"/> | <input type="radio"/> | <input type="radio"/> |
| Discussed sports | <input type="radio"/> | <input type="radio"/> | <input type="radio"/> |
| Read about civil rights and liberties | <input type="radio"/> | <input type="radio"/> | <input type="radio"/> |
| Asked a teacher for advice after class | <input type="radio"/> | <input type="radio"/> | <input type="radio"/> |
| Had vocational counseling | <input type="radio"/> | <input type="radio"/> | <input type="radio"/> |
| Stayed up all night | <input type="radio"/> | <input type="radio"/> | <input type="radio"/> |

Frequently
Occasionally
Not at all

21. Mark only three responses, one in each column.
- | | | | |
|-----------------------|-----------------------|-----------------------|----------------------------------|
| <input type="radio"/> | <input type="radio"/> | <input type="radio"/> | Your probable career occupation. |
| <input type="radio"/> | <input type="radio"/> | <input type="radio"/> | Your father's occupation. |
| <input type="radio"/> | <input type="radio"/> | <input type="radio"/> | Your mother's occupation. |

NOTE: If your father (or mother) is deceased, please indicate his (her) last occupation.

- | | | | |
|------------------------------------------------|-----------------------|-----------------------|-----------------------|
| Accountant or actuary | <input type="radio"/> | <input type="radio"/> | <input type="radio"/> |
| Actor or entertainer | <input type="radio"/> | <input type="radio"/> | <input type="radio"/> |
| Architect | <input type="radio"/> | <input type="radio"/> | <input type="radio"/> |
| Artist | <input type="radio"/> | <input type="radio"/> | <input type="radio"/> |
| Business (clerk) | <input type="radio"/> | <input type="radio"/> | <input type="radio"/> |
| Business executive (management, administrator) | <input type="radio"/> | <input type="radio"/> | <input type="radio"/> |
| Business owner or proprietor | <input type="radio"/> | <input type="radio"/> | <input type="radio"/> |
| Business salesman or buyer | <input type="radio"/> | <input type="radio"/> | <input type="radio"/> |
| Clergyman (minister, priest) | <input type="radio"/> | <input type="radio"/> | <input type="radio"/> |
| Clergy (other religious) | <input type="radio"/> | <input type="radio"/> | <input type="radio"/> |
| Clinical psychologist | <input type="radio"/> | <input type="radio"/> | <input type="radio"/> |
| College teacher | <input type="radio"/> | <input type="radio"/> | <input type="radio"/> |
| Computer programmer | <input type="radio"/> | <input type="radio"/> | <input type="radio"/> |
| Conservationist or forester | <input type="radio"/> | <input type="radio"/> | <input type="radio"/> |
| Dentist (including orthodontist) | <input type="radio"/> | <input type="radio"/> | <input type="radio"/> |
| Dietitian or home economist | <input type="radio"/> | <input type="radio"/> | <input type="radio"/> |
| Engineer | <input type="radio"/> | <input type="radio"/> | <input type="radio"/> |
| Farmer or rancher | <input type="radio"/> | <input type="radio"/> | <input type="radio"/> |
| Foreign service worker (including diplomat) | <input type="radio"/> | <input type="radio"/> | <input type="radio"/> |
| Housewife | <input type="radio"/> | <input type="radio"/> | <input type="radio"/> |
| Interior decorator (including designer) | <input type="radio"/> | <input type="radio"/> | <input type="radio"/> |
| Interpreter (translator) | <input type="radio"/> | <input type="radio"/> | <input type="radio"/> |
| Lab technician or hygienist | <input type="radio"/> | <input type="radio"/> | <input type="radio"/> |
| Law enforcement officer | <input type="radio"/> | <input type="radio"/> | <input type="radio"/> |
| Lawyer (attorney) | <input type="radio"/> | <input type="radio"/> | <input type="radio"/> |
| Military service (career) | <input type="radio"/> | <input type="radio"/> | <input type="radio"/> |
| Musician (performer, composer) | <input type="radio"/> | <input type="radio"/> | <input type="radio"/> |
| Nurse | <input type="radio"/> | <input type="radio"/> | <input type="radio"/> |
| Optometrist | <input type="radio"/> | <input type="radio"/> | <input type="radio"/> |
| Pharmacist | <input type="radio"/> | <input type="radio"/> | <input type="radio"/> |
| Physician | <input type="radio"/> | <input type="radio"/> | <input type="radio"/> |
| School counselor | <input type="radio"/> | <input type="radio"/> | <input type="radio"/> |
| School principal or superintendent | <input type="radio"/> | <input type="radio"/> | <input type="radio"/> |
| Scientific researcher | <input type="radio"/> | <input type="radio"/> | <input type="radio"/> |
| Social worker | <input type="radio"/> | <input type="radio"/> | <input type="radio"/> |
| Statistician | <input type="radio"/> | <input type="radio"/> | <input type="radio"/> |
| Therapist (physical, occupational, speech) | <input type="radio"/> | <input type="radio"/> | <input type="radio"/> |
| Teacher (elementary) | <input type="radio"/> | <input type="radio"/> | <input type="radio"/> |
| Teacher (secondary) | <input type="radio"/> | <input type="radio"/> | <input type="radio"/> |
| Veterinarian | <input type="radio"/> | <input type="radio"/> | <input type="radio"/> |
| Writer or journalist | <input type="radio"/> | <input type="radio"/> | <input type="radio"/> |
| Skilled trades | <input type="radio"/> | <input type="radio"/> | <input type="radio"/> |
| Other | <input type="radio"/> | <input type="radio"/> | <input type="radio"/> |
| Undecided | <input type="radio"/> | <input type="radio"/> | <input type="radio"/> |
| Laborer (unskilled) | <input type="radio"/> | <input type="radio"/> | <input type="radio"/> |
| Semi-skilled worker | <input type="radio"/> | <input type="radio"/> | <input type="radio"/> |
| Other occupation | <input type="radio"/> | <input type="radio"/> | <input type="radio"/> |
| Unemployed | <input type="radio"/> | <input type="radio"/> | <input type="radio"/> |

20. How would you characterize your political views? (Mark one)
- | | |
|--------------------|-----------------------|
| Far left | <input type="radio"/> |
| Liberal | <input type="radio"/> |
| Middle-of-the-road | <input type="radio"/> |
| Conservative | <input type="radio"/> |
| Far right | <input type="radio"/> |

22. Rate yourself on each of the following traits as you really think you are when compared with the average student of your own age. We want the most accurate estimate of how you see yourself. (Mark one for each item)

Trait	Above Average		Below Average	
	Highest 10 Percent	Average	Average	Lowest 10 Percent
Academic ability	<input type="radio"/>	<input type="radio"/>	<input type="radio"/>	<input type="radio"/>
Athletic ability	<input type="radio"/>	<input type="radio"/>	<input type="radio"/>	<input type="radio"/>
Artistic ability	<input type="radio"/>	<input type="radio"/>	<input type="radio"/>	<input type="radio"/>
Cheerfulness	<input type="radio"/>	<input type="radio"/>	<input type="radio"/>	<input type="radio"/>
Defensiveness	<input type="radio"/>	<input type="radio"/>	<input type="radio"/>	<input type="radio"/>
Drive to achieve	<input type="radio"/>	<input type="radio"/>	<input type="radio"/>	<input type="radio"/>
Leadership ability	<input type="radio"/>	<input type="radio"/>	<input type="radio"/>	<input type="radio"/>
Mathematical ability	<input type="radio"/>	<input type="radio"/>	<input type="radio"/>	<input type="radio"/>
Mechanical ability	<input type="radio"/>	<input type="radio"/>	<input type="radio"/>	<input type="radio"/>
Originality	<input type="radio"/>	<input type="radio"/>	<input type="radio"/>	<input type="radio"/>
Political conservatism	<input type="radio"/>	<input type="radio"/>	<input type="radio"/>	<input type="radio"/>
Political liberalism	<input type="radio"/>	<input type="radio"/>	<input type="radio"/>	<input type="radio"/>
Popularity	<input type="radio"/>	<input type="radio"/>	<input type="radio"/>	<input type="radio"/>
Popularity with the opposite sex	<input type="radio"/>	<input type="radio"/>	<input type="radio"/>	<input type="radio"/>
Public speaking ability	<input type="radio"/>	<input type="radio"/>	<input type="radio"/>	<input type="radio"/>
Self-confidence (intellectual)	<input type="radio"/>	<input type="radio"/>	<input type="radio"/>	<input type="radio"/>
Self-confidence (social)	<input type="radio"/>	<input type="radio"/>	<input type="radio"/>	<input type="radio"/>
Sensitivity to criticism	<input type="radio"/>	<input type="radio"/>	<input type="radio"/>	<input type="radio"/>
Stubbornness	<input type="radio"/>	<input type="radio"/>	<input type="radio"/>	<input type="radio"/>
Understanding of others	<input type="radio"/>	<input type="radio"/>	<input type="radio"/>	<input type="radio"/>
Writing ability	<input type="radio"/>	<input type="radio"/>	<input type="radio"/>	<input type="radio"/>

23. Mark one in each row:

	Agree Strongly		Agree somewhat		Disagree somewhat		Disagree strongly	
	Agree strongly	Agree somewhat	Disagree somewhat	Disagree strongly				
The Federal government is not doing enough to control environmental pollution	<input type="radio"/>	<input type="radio"/>	<input type="radio"/>	<input type="radio"/>				
The Federal government is not doing enough to protect the consumer from faulty goods and services	<input type="radio"/>	<input type="radio"/>	<input type="radio"/>	<input type="radio"/>				
The Federal government is not doing enough to promote school desegregation	<input type="radio"/>	<input type="radio"/>	<input type="radio"/>	<input type="radio"/>				
There is too much concern in the courts for the rights of criminals	<input type="radio"/>	<input type="radio"/>	<input type="radio"/>	<input type="radio"/>				
The death penalty should be abolished	<input type="radio"/>	<input type="radio"/>	<input type="radio"/>	<input type="radio"/>				
The activities of married women are best confined to the home and family	<input type="radio"/>	<input type="radio"/>	<input type="radio"/>	<input type="radio"/>				
The "generation gap" between me and my parents is so great that we can barely communicate	<input type="radio"/>	<input type="radio"/>	<input type="radio"/>	<input type="radio"/>				
Marijuana should be legalized	<input type="radio"/>	<input type="radio"/>	<input type="radio"/>	<input type="radio"/>				
Parents should be discouraged from having large families	<input type="radio"/>	<input type="radio"/>	<input type="radio"/>	<input type="radio"/>				
Women should receive the same salary and opportunities for advancement as men in comparable positions	<input type="radio"/>	<input type="radio"/>	<input type="radio"/>	<input type="radio"/>				
Everybody should be given an opportunity to go to college regardless of past performance or aptitude test scores	<input type="radio"/>	<input type="radio"/>	<input type="radio"/>	<input type="radio"/>				
Realistically, an individual person can do little to bring about changes in our society	<input type="radio"/>	<input type="radio"/>	<input type="radio"/>	<input type="radio"/>				

24. Mark one in each row:

	Agree strongly		Agree somewhat		Disagree somewhat		Disagree strongly	
	Agree strongly	Agree somewhat	Disagree somewhat	Disagree strongly				
College officials have the right to regulate student behavior off campus	<input type="radio"/>	<input type="radio"/>	<input type="radio"/>	<input type="radio"/>				
The chief benefit of a college education is that it increases one's earning power	<input type="radio"/>	<input type="radio"/>	<input type="radio"/>	<input type="radio"/>				
Faculty promotions should be based in part on student evaluations	<input type="radio"/>	<input type="radio"/>	<input type="radio"/>	<input type="radio"/>				
College grades should be abolished	<input type="radio"/>	<input type="radio"/>	<input type="radio"/>	<input type="radio"/>				
Colleges would be improved if organized sports were de-emphasized	<input type="radio"/>	<input type="radio"/>	<input type="radio"/>	<input type="radio"/>				
Student publications should be cleared by college officials	<input type="radio"/>	<input type="radio"/>	<input type="radio"/>	<input type="radio"/>				
College officials have the right to ban persons with extreme views from speaking on campus	<input type="radio"/>	<input type="radio"/>	<input type="radio"/>	<input type="radio"/>				
Students from disadvantaged social backgrounds should be given preferential treatment in college admissions	<input type="radio"/>	<input type="radio"/>	<input type="radio"/>	<input type="radio"/>				
Most college officials have been too lax in dealing with student protests on campus	<input type="radio"/>	<input type="radio"/>	<input type="radio"/>	<input type="radio"/>				
Open admissions (admitting anyone who applies) should be adopted by all publicly-supported colleges	<input type="radio"/>	<input type="radio"/>	<input type="radio"/>	<input type="radio"/>				
Even if it employs open admissions, a college should use the same performance standards in awarding degrees to all students	<input type="radio"/>	<input type="radio"/>	<input type="radio"/>	<input type="radio"/>				

25. What is your best guess as to the chances that you will: (Mark one for each item)

	Very Good Chance		Some Chance		Very Little Chance		No Chance	
	Very Good Chance	Some Chance	Very Little Chance	No Chance				
Get married while in college?	<input type="radio"/>	<input type="radio"/>	<input type="radio"/>	<input type="radio"/>				
Get married within a year after college?	<input type="radio"/>	<input type="radio"/>	<input type="radio"/>	<input type="radio"/>				
Vote in the 1972 presidential election?	<input type="radio"/>	<input type="radio"/>	<input type="radio"/>	<input type="radio"/>				
Enlist in the armed services before graduating?	<input type="radio"/>	<input type="radio"/>	<input type="radio"/>	<input type="radio"/>				
Change major field?	<input type="radio"/>	<input type="radio"/>	<input type="radio"/>	<input type="radio"/>				
Change career choice?	<input type="radio"/>	<input type="radio"/>	<input type="radio"/>	<input type="radio"/>				
Fail one or more courses?	<input type="radio"/>	<input type="radio"/>	<input type="radio"/>	<input type="radio"/>				
Graduate with honors?	<input type="radio"/>	<input type="radio"/>	<input type="radio"/>	<input type="radio"/>				
Be elected to a student office?	<input type="radio"/>	<input type="radio"/>	<input type="radio"/>	<input type="radio"/>				
Join a social fraternity, sorority, or club?	<input type="radio"/>	<input type="radio"/>	<input type="radio"/>	<input type="radio"/>				
Be elected to an academic honor society?	<input type="radio"/>	<input type="radio"/>	<input type="radio"/>	<input type="radio"/>				
Make at least a "B" average?	<input type="radio"/>	<input type="radio"/>	<input type="radio"/>	<input type="radio"/>				
Need extra time to complete your degree requirements?	<input type="radio"/>	<input type="radio"/>	<input type="radio"/>	<input type="radio"/>				
Have to work at an outside job?	<input type="radio"/>	<input type="radio"/>	<input type="radio"/>	<input type="radio"/>				
Seek vocational counseling?	<input type="radio"/>	<input type="radio"/>	<input type="radio"/>	<input type="radio"/>				
Seek individual counseling on personal problems?	<input type="radio"/>	<input type="radio"/>	<input type="radio"/>	<input type="radio"/>				
Enroll in honors courses?	<input type="radio"/>	<input type="radio"/>	<input type="radio"/>	<input type="radio"/>				
Get tutoring help in specific courses?	<input type="radio"/>	<input type="radio"/>	<input type="radio"/>	<input type="radio"/>				
Author or co-author a published article?	<input type="radio"/>	<input type="radio"/>	<input type="radio"/>	<input type="radio"/>				
Be more successful after graduation than most students attending this college?	<input type="radio"/>	<input type="radio"/>	<input type="radio"/>	<input type="radio"/>				
Drop out of this college temporarily (exclude transferring)?	<input type="radio"/>	<input type="radio"/>	<input type="radio"/>	<input type="radio"/>				
Drop out permanently (exclude transferring)?	<input type="radio"/>	<input type="radio"/>	<input type="radio"/>	<input type="radio"/>				
Transfer to another college before graduating?	<input type="radio"/>	<input type="radio"/>	<input type="radio"/>	<input type="radio"/>				
Be satisfied with your college?	<input type="radio"/>	<input type="radio"/>	<input type="radio"/>	<input type="radio"/>				

26. Do you feel that you will need any special tutoring or remedial work in any of the following subjects? (Mark all that apply)

English	<input type="checkbox"/>	Mathematics	<input type="checkbox"/>	Science	<input type="checkbox"/>
Reading	<input type="checkbox"/>	Social studies	<input type="checkbox"/>	Foreign language	<input type="checkbox"/>

27. Below is a list of 68 different undergraduate major fields grouped into general categories. Mark only three of the 68 fields as follows:

- ① First choice (your probable major field of study).
- ② Second choice.
- ③ The field of study which is least appealing to you.

ARTS AND HUMANITIES

- Architecture ① ② ③
- English (literature) ... ① ② ③
- Fine arts ① ② ③
- History ① ② ③
- Journalism (writing) ... ① ② ③
- Language (modern) ... ① ② ③
- Language (other) ... ① ② ③
- Music ① ② ③
- Philosophy ① ② ③
- Speech and drama ... ① ② ③
- Theology ① ② ③
- Other ① ② ③

PROFESSIONAL

- Health Technology
(medical, dental,
laboratory) ① ② ③
- Nursing ① ② ③
- Pharmacy ① ② ③
- Pre dentistry ① ② ③
- Prelaw ① ② ③
- Premedical ① ② ③
- Preveterinary ① ② ③
- Therapy (occupat.,
physical, speech) ... ① ② ③
- Other ① ② ③

BIOLOGICAL SCIENCE

- Biology (general) ... ① ② ③
- Biochemistry ① ② ③
- Biophysics ① ② ③
- Botany ① ② ③
- Zoology ① ② ③
- Other ① ② ③

SOCIAL SCIENCE

- Anthropology ① ② ③
- Economics ① ② ③
- Education ① ② ③
- History ① ② ③
- Political Science
(government,
int. relations) ① ② ③
- Psychology ① ② ③
- Social work ① ② ③
- Sociology ① ② ③
- Other ① ② ③

BUSINESS

- Accounting ① ② ③
- Business admin. ... ① ② ③
- Electronic data
processing ① ② ③
- Secretarial studies ... ① ② ③
- Other ① ② ③

OTHER FIELDS

- Agriculture ① ② ③
- Communications
(radio, T.V., etc.) ... ① ② ③
- Computer Science ... ① ② ③
- Environmental Science ① ② ③
- Electronics
(technology) ① ② ③
- Forestry ① ② ③
- Home economics ① ② ③
- Industrial arts ① ② ③
- Library science ① ② ③
- Military science ① ② ③
- Physical education
and recreation ① ② ③
- Other (technical) ... ① ② ③
- Other
(nontechnical) ① ② ③
- Undecided ① ② ③

ENGINEERING

- Aeronautical ① ② ③
- Civil ① ② ③
- Chemical ① ② ③
- Electrical ① ② ③
- Industrial ① ② ③
- Mechanical ① ② ③
- Other ① ② ③

PHYSICAL SCIENCE

- Chemistry ① ② ③
- Earth science ① ② ③
- Mathematics ① ② ③
- Physics ① ② ③
- Statistics ① ② ③
- Other ① ② ③

Please be sure that only three circles have been marked in the above list.

28. Indicate the importance to you personally of each of the following: (Mark one for each item)

- Becoming accomplished in one of the performing arts
(acting, dancing, etc.) ③ ② ① ④
- Becoming an authority in my field ③ ② ① ④
- Obtaining recognition from my colleagues for con-
tributions in my special field ③ ② ① ④
- Influencing the political structure ③ ② ① ④
- Influencing social values ③ ② ① ④
- Raising a family ③ ② ① ④
- Having an active social life ③ ② ① ④
- Having friends with different backgrounds and
interests from mine ③ ② ① ④
- Becoming an expert in finance and commerce ③ ② ① ④
- Having administrative responsibility for the work of others ③ ② ① ④
- Being very well-off financially ③ ② ① ④
- Helping others who are in difficulty ③ ② ① ④
- Participating in an organization like the Peace Corps or Vista ③ ② ① ④
- Becoming a community leader ③ ② ① ④
- Making a theoretical contribution to science ③ ② ① ④
- Writing original works (poems, novels, short stories, etc.) ③ ② ① ④
- Never being obligated to people ③ ② ① ④
- Creating artistic work (painting, sculpture, decorating, etc.) ③ ② ① ④
- Keeping up to date with political affairs ③ ② ① ④
- Being successful in a business of my own ③ ② ① ④
- Becoming involved in programs to clean up the environment ③ ② ① ④
- Developing a meaningful philosophy of life ③ ② ① ④
- Participating in a community action program ③ ② ① ④
- Getting married within the next five years ③ ② ① ④

Essential
Very Important
Somewhat Important
Not Important

29. Below are some of the reasons that might have influenced your decision to attend this particular college. How important was each reason in deciding to come here?

- (Mark one answer for each statement.)
- My relatives wanted me to come here ④ ③ ② ①
- This college has a very good reputation ④ ③ ② ①
- Most of my friends are going to this college ④ ③ ② ①
- Because of low tuition ④ ③ ② ①
- Someone who had been here before advised me to go ④ ③ ② ①
- Because of the special educational programs offered ④ ③ ② ①
- I was not accepted anywhere else ④ ③ ② ①
- My guidance counselor advised me to go ④ ③ ② ①
- I wanted to live at home ④ ③ ② ①

Very Important
Somewhat Important
Not Important

DIRECTIONS:

The remaining circles are provided for items specifically designed by your college, rather than by the American Council on Education. If your college has chosen to use the circles, observe carefully the supplemental directions given you.

- 30. A B C D E
- 31. A B C D E
- 32. A B C D E
- 33. A B C D E
- 34. A B C D E
- 35. A B C D E
- 36. A B C D E
- 37. A B C D E
- 38. A B C D E
- 39. A B C D E

DO NOT MARK				
0	0	0	0	0
1	1	1	1	1
2	2	2	2	2
3	3	3	3	3
4	4	4	4	4
5	5	5	5	5
6	6	6	6	6
7	7	7	7	7
8	8	8	8	8
9	9	9	9	9
1	2	3	4	A

APPENDIX C

Coding Scheme for Collapsed Items

National Norms for Entering College Freshmen, Fall 1971

Probable Major Field of Study
Probable Occupation
Father's Occupation

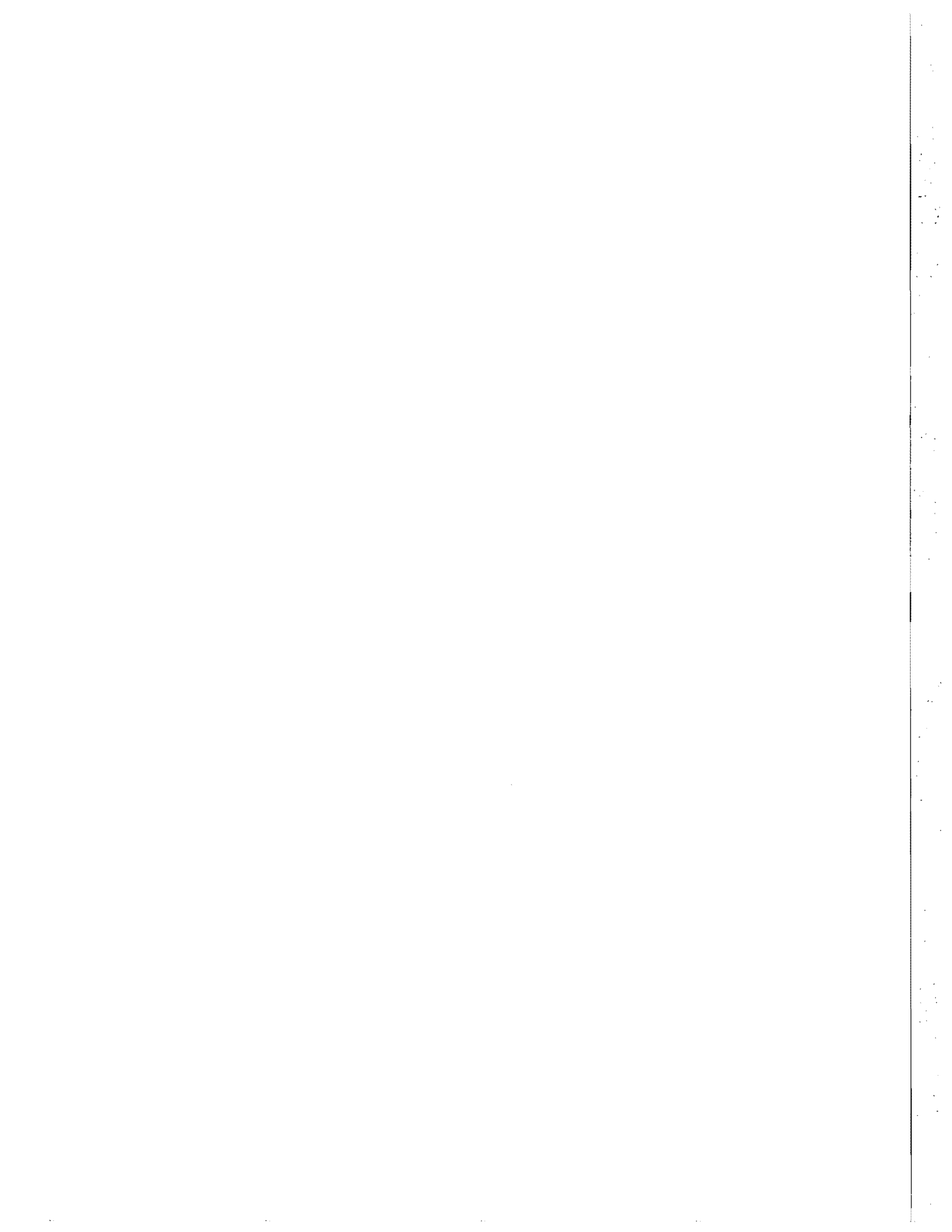

Probable Major Field of Study

Collapsed Category	Item Response Alternatives
Agriculture	Agriculture; Forestry
Biological Sciences	Biology (general); Biochemistry; Biophysics; Botany; Zoology; Other Biological Sciences
Business	Accounting; Business Administration; Data Processing; Secretarial Studies; Other Business
Education	Education; Physical Education and Recreation
Engineering	Aeronautical; Civil; Chemical; Electrical; Industrial; Mechanical; Other Engineering
English	English (literature)
Health Professions	Health Technology; Nursing; Pharmacy; Therapy
History and Political Science	History (Arts and Humanities); History (Social Science); Political Science
Humanities (Other)	Language (modern); Language (other); Philosophy; Theology; Other Arts and Humanities
Fine Arts	Architecture; Fine Arts; Journalism; Music; Speech and Drama
Mathematics and Statistics	Mathematics; Statistics
Physical Sciences	Chemistry; Earth Science; Physics; Other Physical Science
Preprofessional	Pre dentistry; Prelaw; Premedical; Preveterinary
Social Sciences	Anthropology; Economics; Psychology; Social Work; Sociology; Other Social Science
Other Fields (Technical)	Other Professional; Communications; Computer Science; Environmental Science; Electronics; Industrial Arts; Other Technical
Other Fields (Nontechnical)	Home Economics; Library Science; Military Science; Other Nontechnical
Undecided	Undecided

Probable Occupation

<u>Collapsed Category</u>	<u>Item Response Alternatives</u>
Artist (including Performer)	Actor or Entertainer; Artist; Interior Decorator; Musician; Writer or Journalist
Businessman	Accountant or Actuary; Business Executive; Business Owner or Proprietor; Business Salesman or Buyer
Clergyman	Clergyman; Clergy (other religious)
College Teacher	College Teacher
Doctor (M.D. or D.D.S.)	Dentist (including orthodontist); Physician
Educator (secondary)	School Counselor; School Principal or Superintendent; Teacher (secondary)
Elementary Teacher	Teacher (elementary)
Engineer	Engineer
Farmer or Forester	Conservationist or Forester; Farmer or Rancher
Health Professional	Dietician or Home Economist; Lab Technician or Hygienist; Optometrist; Pharmacist; Therapist; Veterinarian
Lawyer	Lawyer (attorney)
Nurse	Nurse
Research Scientist	Scientific Researcher
Other Choice	Architect; Business (clerical); Clinical Psychologist; Computer Programmer; Foreign Service Worker; Housewife; Interpreter; Law Enforcement Officer; Military Service; Social Worker; Statistician; Skilled Trades; Other
Undecided	Undecided

Father's Occupation

Collapsed Category	Item Response Alternatives
Artist (including Performer)	Actor or Entertainer; Artist; Interior Decorator; Musician; Writer or Journalist
Businessman	Accountant or Actuary; Business Executive; Business Owner or Proprietor; Business Salesman or Buyer
Clergyman	Clergyman; Clergy (other religious)
College Teacher	College Teacher
Doctor (M.D. or D.D.S.)	Dentist (including orthodontist); Physician
Educator (secondary)	School Counselor; School Principal or Superintendent; Teacher (secondary)
Elementary Teacher	Teacher (elementary)
Engineer	Engineer
Farmer or Forester	Conservationist or Forester; Farmer or Rancher
Health Professional	Dietician or Home Economist; Lab Technician or Hygienist; Optometrist; Pharmacist; Therapist; Veterinarian
Lawyer	Lawyer (attorney)
Military Career	Military Service (career)
Research Scientist	Scientific Researcher
Skilled Worker	Skilled Trades
Semi-skilled Worker	Semi-skilled Worker
Unskilled Worker	Laborer (unskilled)
Unemployed	Unemployed
Other	Architect; Business (clerical); Clinical Psychologist; Computer Programmer; Foreign Service Worker; Housewife; Interpreter; Law Enforcement Officer; Nurse; Social Worker; Statistician; Other Occupation



APPENDIX D

Relationship Between Stratification Cell
Assignment and Norms Group Inclusion for
Institutions in the Normative Sample



RELATIONSHIP BETWEEN STRATIFICATION CELL ASSIGNMENT
AND NORMS GROUP INCLUSION FOR INSTITUTIONS IN THE NORMATIVE SAMPLE

STRATIFICATION CELL

	1	2	3	4	5	6	7	8	9	10	11	12	13	14	15	16	17	18	19	20	21	22	23	24	25	26	27	28	29	30	31	32	33	34	35	36	
TWO-YEAR PUBLIC	0	0	0	0	0	0	0	0	0	0	0	0	0	0	0	0	0	0	0	0	0	0	0	0	0	5	14	11	7	0	0	0	0	0	0	2	
TWO-YEAR PRIVATE	0	0	0	0	0	0	0	0	0	0	0	0	0	0	0	0	0	0	0	0	0	0	0	0	0	0	0	0	4	12	6	3	0	0	0		
TECHNOLOGICAL	0	0	0	0	0	0	0	0	6	1	0	0	2	2	1	0	0	0	0	0	0	0	0	0	0	0	0	0	0	0	0	0	0	0	0	0	
FOUR-YEAR PUBLIC	0	0	0	0	0	5	9	5	5	0	0	0	0	0	0	0	0	0	0	0	0	0	0	0	0	0	0	0	0	0	0	0	0	0	9	0	0
PRIVATE NONSECTARIAN	0	0	0	0	0	0	0	0	0	13	8	18	18	8	0	0	0	0	0	0	0	0	0	0	0	0	0	0	0	0	0	0	0	0	0	5	0
PROTESTANT	0	0	0	0	0	0	0	0	0	0	0	0	0	0	0	0	0	0	10	10	22	18	5	0	0	0	0	0	0	0	0	0	0	0	0	4	0
ROMAN CATHOLIC	0	0	0	0	0	0	0	0	0	0	0	0	0	0	16	14	12	4	0	0	0	0	0	0	0	0	0	0	0	0	0	0	0	0	0	0	0
PUBLIC UNIVERSITIES	7	5	5	0	0	0	0	0	0	0	0	0	0	0	0	0	0	0	0	0	0	0	0	0	0	0	0	0	0	0	0	0	0	0	0	0	0
PRIVATE UNIVERSITIES	0	0	0	6	2	7	0	0	0	0	0	0	0	0	0	0	0	0	0	0	0	0	0	0	0	0	0	0	0	0	0	0	0	0	0	0	0
MENS PRIV. NONSECT.	0	0	0	0	0	0	0	0	0	1	0	3	7	0	0	0	0	0	0	0	0	0	0	0	0	0	0	0	0	0	0	0	0	0	0	0	0
WOMENS PRIV. NONSECT.	0	0	0	0	0	0	0	0	0	1	0	4	5	0	0	0	0	0	0	0	0	0	0	0	0	0	0	0	0	0	0	0	0	0	0	1	0
COED PRIV. NONSECT.	0	0	0	0	0	0	0	0	0	11	8	11	6	8	0	0	0	0	0	0	0	0	0	0	0	0	0	0	0	0	0	0	0	0	0	4	0
CATHOLIC MALE	0	0	0	0	0	0	0	0	0	0	0	0	0	0	4	4	2	0	0	0	0	0	0	0	0	0	0	0	0	0	0	0	0	0	0	0	0
CATHOLIC FEMALE	0	0	0	0	0	0	0	0	0	0	0	0	0	0	7	4	5	0	0	0	0	0	0	0	0	0	0	0	0	0	0	0	0	0	0	0	0
CATHOLIC COED	0	0	0	0	0	0	0	0	0	0	0	0	0	0	5	6	5	4	0	0	0	0	0	0	0	0	0	0	0	0	0	0	0	0	0	0	0
TWO-YEAR COLLEGES	0	0	0	0	0	0	0	0	0	0	0	0	0	0	0	0	0	0	0	0	0	0	0	0	0	5	14	11	7	4	12	6	3	0	0	2	
FOUR-YEAR COLLEGES	0	0	0	0	0	5	9	11	6	13	8	20	20	9	16	14	12	4	10	10	22	18	5	0	0	0	0	0	0	0	0	0	0	0	9	9	0
UNIVERSITIES	7	5	5	6	2	7	0	0	0	0	0	0	0	0	0	0	0	0	0	0	0	0	0	0	0	0	0	0	0	0	0	0	0	0	0	0	0
PREDOMINANTLY BLACK	0	0	0	0	0	0	0	0	0	0	0	0	0	0	0	0	0	0	0	0	0	0	0	0	0	0	0	0	0	0	0	0	0	9	9	2	
DATA BANK SAMPLE	7	5	5	6	2	7	5	9	11	6	13	8	20	20	9	16	14	12	4	10	10	22	18	5	0	5	14	11	7	4	12	6	3	9	9	2	
EASTERN REGION	1	1	0	4	0	4	0	7	6	3	3	5	12	14	7	4	7	4	3	1	2	5	3	1	0	2	3	4	4	1	5	3	1	2	1	0	
MIDWESTERN REGION	3	2	2	1	2	0	1	1	1	3	6	2	3	2	1	6	5	5	1	4	2	12	10	1	0	1	6	3	2	0	3	0	0	0	0	0	
SOUTHERN REGION	2	1	1	0	0	2	4	1	3	0	4	1	4	0	2	0	1	0	4	6	5	3	2	0	1	2	2	0	2	3	3	2	7	8	2	0	
WESTERN REGION	1	1	2	1	0	1	0	0	1	0	0	0	1	4	1	4	2	2	0	1	0	0	2	1	0	1	3	2	1	1	1	0	0	0	0	0	



APPENDIX E

Sample Report Furnished to a
Participating Institution



ITEM DESCRIPTION	NUMBER OF RESPONDENTS (*)	Name of Institution			4-YR COLLEGES NATL NORMS		
		MALE	FEMALE	TOTAL	MALE	FEMALE	TOTAL
(PERCENTAGES)							
NUMBER OF STUDENTS	505.	69.9	30.1	100.0	50.0	50.0	100.0
AGE BY DECEMBER 31, 1971							
	505.						
16 OR YOUNGER		.0	.0	.0	.1	.1	.1
17		3.1	7.2	4.4	3.0	4.8	3.9
18		83.3	90.8	85.5	75.3	81.6	78.5
19		12.5	1.3	9.1	16.4	11.3	13.9
20		1.1	.7	1.0	1.7	.9	1.3
21		.0	.0	.0	.6	.3	.4
22-25		.0	.0	.0	2.2	.5	1.3
26 OR OLDER		.0	.0	.0	.8	.5	.7
FATHER'S EDUCATION							
	497.						
GRAMMAR SCHOOL OR LESS		1.4	.7	1.2	8.3	7.6	8.0
SOME HIGH SCHOOL		5.2	6.6	5.6	14.9	14.4	14.7
HIGH SCHOOL GRADUATE		22.3	19.9	21.5	30.2	28.9	29.5
SOME COLLEGE		13.3	13.2	13.3	16.6	17.4	17.0
COLLEGE DEGREE		34.7	31.8	33.8	19.1	20.0	19.6
POSTGRADUATE DEGREE		23.1	27.8	24.5	10.8	11.7	11.2
MOTHER'S EDUCATION							
	500.						
GRAMMAR SCHOOL OR LESS		1.4	.0	1.0	4.7	4.2	4.5
SOME HIGH SCHOOL		6.0	2.0	4.8	12.7	12.2	12.5
HIGH SCHOOL GRADUATE		37.2	36.4	37.0	45.3	41.5	43.4
SOME COLLEGE		19.8	21.9	20.4	17.3	20.3	18.8
COLLEGE DEGREE		30.7	31.1	30.8	16.2	17.6	16.9
POSTGRADUATE DEGREE		4.9	8.6	6.0	3.7	4.2	4.0
RACIAL BACKGROUND (1)							
	505.						
WHITE/CAUCASIAN		96.9	94.7	96.2	89.5	88.5	89.0
BLACK/NEGRO/AFRO-AMERICAN		2.3	3.9	2.8	8.8	10.1	9.4
AMERICAN INDIAN		.0	.0	.0	.9	.9	.9
ORIENTAL		.0	.7	.2	.5	.4	.4
MEXICAN-AMERICAN/CHICANO		.0	.0	.0	.3	.3	.3
PUERTO RICAN-AMERICAN		.3	.0	.2	.4	.3	.3
OTHER		.6	.7	.6	1.0	1.0	1.0
ESTIMATED PARENTAL INCOME							
	486.						
LESS THAN \$4,000		1.5	.7	1.2	4.6	5.6	5.1
\$4,000 - \$5,999		1.2	2.8	1.6	6.5	7.3	6.9
\$6,000 - \$7,999		5.0	2.8	4.3	8.9	9.7	9.3
\$8,000 - \$9,999		6.4	9.8	7.4	11.6	11.9	11.8
\$10,000 - \$12,499		11.4	11.9	11.5	17.4	16.6	17.0
\$12,500 - \$14,999		14.9	13.3	14.4	14.6	13.6	14.1
\$15,000 - \$19,999		17.2	14.7	16.5	15.3	14.0	14.6
\$20,000 - \$24,999		15.7	16.1	15.8	8.5	8.6	8.5
\$25,000 - \$29,999		8.7	11.2	9.5	4.1	4.3	4.2
\$30,000 - \$34,999		7.6	4.9	6.8	2.6	3.0	2.8
\$35,000 - \$39,999		4.7	4.2	4.5	1.5	1.6	1.6
\$40,000 OR MORE		5.8	7.7	6.4	4.3	3.8	4.0

AMERICAN COUNCIL ON EDUCATION OFFICE OF RESEARCH
SUMMARY OF DATA ON ENTERING FRESHMEN
(FALL 1971)

Name of Institution

PAGE 2 OF 8

ITEM DESCRIPTION	NUMBER OF RESPONDENTS	Name of Institution			4-YR COLLEGES NATL NORMS		
		MALE	FEMALE	TOTAL	MALE	FEMALE	TOTAL
(PERCENTAGES)							
RELIGION REARED	501.						
PROTESTANT		68.6	76.2	70.9	50.5	54.6	52.5
ROMAN CATHOLIC		22.0	20.5	21.6	34.5	31.2	32.8
JEWISH		3.7	.0	2.6	3.3	3.0	3.1
OTHER		4.6	2.0	3.8	9.4	9.6	9.5
NONE		1.1	1.3	1.2	2.3	1.7	2.0
RELIGIOUS PREFERENCE	495.						
PROTESTANT		56.2	70.0	60.4	42.0	47.4	44.7
ROMAN CATHOLIC		15.9	14.7	15.6	28.6	26.7	27.6
JEWISH		2.6	.0	1.8	2.4	2.2	2.3
OTHER		6.4	4.7	5.9	11.7	11.8	11.8
NONE		18.8	10.7	16.4	15.3	11.9	13.6
FATHER'S OCCUPATION (2)	485.						
ARTIST (INCL PERFORMER)		1.5	.7	1.2	.7	.8	.8
BUSINESSMAN		42.4	46.2	43.5	30.9	30.5	30.7
CLERGYMAN		.9	2.1	1.2	1.3	1.3	1.3
COLLEGE TEACHER		.3	1.4	.6	.8	.9	.9
DOCTOR (M.D. OR D.D.S.)		5.6	8.3	6.4	2.2	2.2	2.2
EDUCATOR (SECONDARY)		3.2	6.2	4.1	2.7	2.9	2.8
ELEMENTARY TEACHER		.3	.7	.4	.4	.4	.4
ENGINEER		11.2	5.5	9.5	6.9	7.1	7.0
FARMER OR FORESTER		.9	1.4	1.0	5.1	6.5	5.3
HEALTH PROFESSIONAL (NON-M.D.)		1.2	1.4	1.2	1.1	1.2	1.2
LAWYER		4.1	2.1	3.5	1.4	1.4	1.4
MILITARY CAREER		.9	2.1	1.2	3.0	1.9	2.5
RESEARCH SCIENTIST		2.6	.7	2.1	.5	.6	.6
SKILLED WORKER		8.9	4.8	5.6	12.3	10.4	11.3
SEMI-SKILLED WORKER		3.8	2.8	3.5	8.0	6.3	7.1
UNSKILLED WORKER		1.5	.0	1.0	3.8	3.8	3.8
UNEMPLOYED		1.2	.7	1.0	1.1	1.5	1.3
OTHER		12.6	13.1	12.8	17.6	21.3	19.5
VETERAN	505.						
NO		100.0	100.0	100.0	96.7	99.7	98.2
YES, SERVED IN SOUTHEAST ASIA		.0	.0	.0	1.6	.0	.8
YES, DID NOT SERVE IN SE ASIA		.0	.0	.0	1.8	.3	1.0
MARITAL STATUS **	493.						
PRESENTLY MARRIED		.3	.0	.2	2.2	1.5	1.8
NOT MARRIED		99.7	100.0	99.8	97.8	98.5	98.2
DISTANCE FROM HOME TO COLLEGE	496.						
5 MILES OR LESS		.6	.7	.6	7.0	7.2	7.1
6-10 MILES		.3	.0	.2	6.9	6.0	6.4
11-50 MILES		5.2	7.9	6.0	20.8	21.5	21.1
51-100 MILES		17.1	18.5	17.5	15.0	18.5	16.7
101-500 MILES		73.0	68.2	71.6	33.9	36.5	35.2
MORE THAN 500 MILES		3.8	4.6	4.0	16.5	10.4	13.5

ITEM DESCRIPTION	NUMBER OF RESPONDENTS	Name of Institution			4-YR COLLEGES NATL NORMS		
		MALE	FEMALE	TOTAL	MALE	FEMALE	TOTAL
(PERCENTAGES)							
AVERAGE GRADE IN HIGH SCHOOL	497.						
A OR A+		2.6	25.2	9.5	4.8	7.4	6.1
A-		7.8	33.1	15.5	8.4	12.9	10.6
B+		27.7	28.5	28.0	16.7	24.0	20.4
B		34.4	9.9	27.0	24.2	28.4	26.3
B-		17.9	2.6	13.3	17.9	13.5	15.7
C+		7.2	.0	5.0	16.4	9.1	12.7
C		2.3	.7	1.8	11.1	4.4	7.7
D		.0	.0	.0	.6	.2	.4
RANK IN HIGH SCHOOL CLASS	500.						
TOP QUARTER		60.0	94.0	70.2	42.6	55.6	49.1
SECOND QUARTER		34.6	3.3	25.2	33.8	30.1	32.0
THIRD QUARTER		4.0	2.7	3.6	20.3	12.7	16.8
FOURTH QUARTER		1.4	.0	1.0	3.3	1.6	2.4
SECONDARY SCHOOL ACHIEVEMENTS	505.						
PRESIDENT STUDENT ORGANIZATION		24.1	25.7	24.6	22.5	20.4	21.5
HIGH RATING STATE MUSIC CONTEST		6.5	9.9	7.5	9.5	12.7	11.1
STATE/REGIONAL SPEECH CONTEST		2.3	1.3	2.0	4.9	5.6	5.3
MAJOR PART IN A PLAY		15.9	20.4	17.2	16.6	17.2	16.9
VARSITY LETTER (SPORTS)		70.3	25.7	56.8	52.7	16.7	34.7
AWARD IN ART COMPETITION		3.4	8.6	5.0	4.6	6.6	5.6
EDITOR OF SCHOOL PAPER		12.5	27.0	16.8	9.7	16.8	13.3
ORIGINAL WRITING PUBLISHED		18.7	34.2	23.4	14.8	20.1	17.5
NSF SUMMER PROGRAM		.3	1.3	.6	.9	.6	.8
STATE/REGIONAL SCIENCE PROGRAM		1.1	2.6	1.6	2.3	1.8	2.0
SCHOLASTIC HONOR SOCIETY		27.8	75.0	42.0	23.4	35.6	29.5
NATIONAL MERIT RECOGNITION		7.6	19.1	11.1	8.9	8.8	8.9
YEAR FINISH SECONDARY SCHOOL **	504.						
GRADUATED IN 1971		97.2	98.7	97.6	91.9	95.4	93.6
DID NOT GRADUATE IN 1971		2.8	1.3	2.4	8.1	4.6	6.4
HIGHEST DEGREE PLANNED	500.						
NONE		2.3	2.0	2.2	4.1	4.3	4.2
ASSOCIATE (OR EQUIVALENT)		.6	.0	.4	1.1	2.5	1.8
BACHELOR'S (B.A., B.S.)		27.8	34.4	29.8	34.2	47.2	40.7
MASTER'S (M.A., M.S.)		30.4	47.0	35.4	31.0	33.7	32.4
PH.D. OR ED.D.		8.9	6.6	8.2	12.7	6.4	9.6
M.D., D.O., D.D.S., OR D.V.M.		14.9	7.3	12.6	7.0	2.3	4.7
LL.B. OR J.D. (LAW)		12.6	2.0	9.4	7.1	1.5	4.3
B.D. (DIVINITY)		.9	.0	.6	.8	.1	.4
OTHER		1.7	.7	1.4	2.0	2.1	2.0
CONCERN ABOUT FINANCING COLLEGE	503.						
NO CONCERN		40.2	34.9	38.6	35.7	29.2	32.5
SOME CONCERN		51.6	58.6	53.7	53.8	57.9	55.8
MAJOR CONCERN		8.3	6.6	7.8	10.5	12.9	11.7

AMERICAN COUNCIL ON EDUCATION OFFICE OF RESEARCH
SUMMARY OF DATA ON ENTERING FRESHMEN
(FALL 1971)

Name of Institution

PAGE 4 OF 8

ITEM DESCRIPTION	NUMBER OF RESPONDENTS	Name of Institution			4-YR COLLEGES NATL NORMS		
		MALE	FEMALE	TOTAL	MALE	FEMALE	TOTAL
(PERCENTAGES)							
MAJOR SOURCES OF FINANCIAL SUPPORT FOR COLLEGE (1)	505.						
PART-TIME OR SUMMER WORK		15.6	10.5	14.1	26.5	20.2	24.4
SAVINGS FROM FULL-TIME EMPLOY		5.1	1.3	4.0	10.1	5.3	7.7
PARENTAL OR FAMILY AID OR GIFTS		82.2	84.2	82.8	50.9	63.9	57.4
PARENT'S MILITARY SERVICE		.6	.7	.6	1.8	1.8	1.8
PERSONAL MILITARY SERVICE		.0	.0	.0	3.4	.1	1.8
SCHOLARSHIPS AND GRANTS		27.5	25.0	26.7	23.8	25.1	24.5
LOANS-NDEA/GOV'T INSURED/COLLEGE		19.0	19.7	19.2	15.9	19.4	17.7
OTHER REPAYABLE LOANS		7.1	7.9	7.3	6.6	6.9	7.7
PROBABLE MAJOR FIELD OF STUDY(2)	493.						
AGRICULTURE (INCL FORESTRY)		2.0	.7	1.6	2.4	.2	1.3
BIOLOGICAL SCIENCES		8.5	10.6	9.1	5.3	3.1	4.2
BUSINESS		12.0	4.0	9.5	16.7	7.3	11.9
EDUCATION		2.6	7.3	4.1	6.1	20.8	13.5
ENGINEERING		.3	.0	.2	10.7	.2	5.4
ENGLISH		2.0	6.0	3.2	1.6	4.2	2.9
HEALTH PROFESSIONS (NON-M.D.)		1.2	1.3	1.2	2.3	12.8	7.6
HISTORY, POLITICAL SCIENCE		14.3	4.6	11.4	7.8	4.1	5.9
HUMANITIES (OTHER)		3.2	11.3	5.7	3.2	5.1	4.2
FINE ARTS		5.8	13.9	8.3	7.2	11.2	9.2
MATHEMATICS OR STATISTICS		4.1	5.3	4.5	3.4	3.7	3.6
PHYSICAL SCIENCES		2.9	2.6	2.8	3.8	.9	2.3
PRE-PROFESSIONAL		24.6	8.6	19.7	13.5	3.5	6.4
SOCIAL SCIENCES		9.9	17.2	12.2	7.1	14.4	10.8
OTHER FIELDS (TECHNICAL)		2.0	1.3	1.8	4.7	2.1	3.4
OTHER FIELDS (NONTECHNICAL)		.3	3.3	1.2	2.0	4.2	3.2
UNDECIDED		4.1	2.0	3.4	2.3	2.3	2.3
PROBABLE CAREER OCCUPATION (2)	490.						
ARTIST (INCL PERFORMER)		2.3	7.5	3.9	5.3	7.9	6.6
BUSINESSMAN		13.7	1.4	10.0	14.8	3.2	8.9
CLERGYMAN		1.2	.7	1.0	1.9	.3	1.1
COLLEGE TEACHER		1.2	.7	1.0	1.1	.7	.9
DOCTOR (M.D. OR D.D.S.)		14.3	4.8	11.4	7.0	1.9	4.4
EDUCATOR (SECONDARY)		7.6	12.9	9.2	9.7	14.7	12.2
ELEMENTARY TEACHER		.3	12.9	4.1	1.3	18.0	9.7
ENGINEER		.0	.0	.0	8.0	.2	4.1
FARMER OR FORESTER		2.3	2.7	2.4	2.7	.4	1.6
HEALTH PROFESSIONAL (NON-M.D.)		2.3	3.4	2.7	3.1	7.8	5.4
LAWYER		16.3	2.0	12.0	8.5	1.7	5.1
NURSE		.0	.0	.0	.1	6.4	3.3
RESEARCH SCIENTIST		2.6	4.8	3.3	3.5	1.6	2.6
OTHER		8.7	21.1	12.4	19.2	21.3	20.3
UNDECIDED		27.1	25.2	26.5	13.9	13.8	13.9

AMERICAN COUNCIL ON EDUCATION OFFICE OF RESEARCH
SUMMARY OF DATA ON ENTERING FRESHMEN
(FALL 1971)

Name of Institution

ITEM DESCRIPTION	NUMBER OF RESPONDENTS	Name of Institution			4-YR COLLEGES NATL NORMS		
		MALE	FEMALE	TOTAL	MALE	FEMALE	TOTAL
----- (PERCENTAGES) -----							
REASONS NOTED AS VERY IMPORTANT IN DECIDING TO GO TO COLLEGE **							
PARENTS WANTED ME TO GO	502.	23.4	24.3	23.7	22.9	25.4	24.1
CONTRIBUTE MORE TO MY COMMUNITY	498.	19.9	25.8	21.7	17.1	28.1	21.1
GET A BETTER JOB	501.	72.9	58.9	68.7	74.2	66.9	70.5
GAIN A GENERAL EDUCATION	500.	60.1	82.2	66.8	56.5	69.0	62.7
IMPROVE READING/STUDY SKILLS	493.	16.0	14.8	15.6	22.2	22.8	22.5
NOTHING BETTER TO DO	494.	2.6	.7	2.0	2.0	2.2	2.1
BECOME MORE CULTURED	495.	23.8	36.4	27.7	26.4	35.8	31.1
MAKE MORE MONEY	497.	44.7	26.7	39.2	52.8	36.8	44.8
LEARN MORE ABOUT MY INTERESTS	498.	61.6	88.2	69.7	64.4	74.5	69.5
MEET NEW/INTERESTING PEOPLE	498.	45.0	70.2	52.6	39.0	56.8	48.0
PREPARE FOR GRAD OR PROF SCHOOL	499.	52.0	37.1	47.5	39.4	28.8	34.1

REASONS NOTED AS VERY IMPORTANT IN SELECTING THIS COLLEGE **							
RELATIVES WANTED ME TO GO	504.	4.3	9.2	5.8	6.6	9.3	8.0
COLLEGE HAS A GOOD REPUTATION	505.	46.7	55.9	49.5	38.8	40.3	39.6
MOST FRIENDS GOING TO THIS COL	505.	.3	1.3	.6	3.3	3.5	3.4
LOW TUITION	503.	1.7	.7	1.4	12.6	12.9	12.7
ADVICE OF SOMEONE WHO ATTENDED	504.	15.0	20.5	16.7	16.1	16.7	16.4
SPECIAL EDUC PROGRAM OFFERED	504.	21.0	25.2	22.2	30.1	36.3	33.2
NOT ACCEPTED ANYWHERE ELSE	504.	4.8	2.6	4.2	3.4	2.3	2.8
ADVICE OF GUIDANCE COUNSELOR	504.	7.6	6.6	7.3	7.0	6.1	6.5
WANTED TO LIVE AT HOME	503.	.8	.0	.6	7.2	6.4	6.8

NEED FOR SPECIAL HELP IN (1) **							
ENGLISH	505.	10.5	6.6	9.3	20.4	10.5	15.4
READING		8.8	4.6	7.5	11.9	7.4	9.6
MATHEMATICS		21.5	17.1	20.2	34.5	41.0	37.7
SOCIAL STUDIES		.8	.0	.6	3.2	4.4	3.8
SCIENCE		22.1	25.0	23.0	18.3	29.4	23.9
FOREIGN LANGUAGE		49.6	26.3	42.6	29.9	19.8	24.9

AGREE STRONGLY OR SOMEWHAT							
GOV'T NOT CONTROLLING POLLUTION	504.	93.2	96.7	94.2	90.8	91.5	91.1
GOV'T NOT PROTECTING CONSUMER	502.	80.1	80.8	80.3	75.8	77.6	76.7
GOV'T NOT DESEGREGATING QUICKLY	498.	49.6	55.0	51.2	49.9	52.3	51.1
TOO MANY RIGHTS FOR CRIMINALS	502.	47.7	36.7	44.4	52.7	39.8	46.3
SHOULD ABOLISH DEATH PENALTY	502.	57.2	65.1	59.6	54.8	65.1	60.0
WOMEN'S ACTIVITIES BEST IN HOME	504.	42.9	18.4	35.5	51.0	30.6	40.8
BARELY COMMUNICATE WITH PARENTS	504.	11.1	11.8	11.3	19.0	15.1	17.1
SHOULD LEGALIZE MARIJUANA	501.	41.0	32.0	38.3	41.1	34.5	37.8
SHOULD DISCOURAGE LARGE FAMILIES	501.	81.2	82.7	81.6	69.6	67.2	68.4
WOMEN SHOULD GET JOB EQUALITY	504.	86.9	98.0	90.3	83.3	94.6	88.9
ALL SHOULD GET COL OPPORTUNITY	504.	44.3	50.7	46.2	61.3	67.2	64.3
CAN DO LITTLE TO CHANGE SOCIETY	504.	45.5	35.5	42.5	44.6	38.0	41.3

AMERICAN COUNCIL ON EDUCATION OFFICE OF RESEARCH
SUMMARY OF DATA ON ENTERING FRESHMEN
(FALL 1971)

ITEM DESCRIPTION	NUMBER OF RESPONDENTS	Name of Institution			4-YR COLLEGES NATL NORMS		
		MALE	FEMALE	TOTAL	MALE	FEMALE	TOTAL
----- (PERCENTAGES) -----							
AGREE STRONGLY OR SOMEWHAT							
COL REGULATE STUDENTS OFF CAMPUS	504.	17.3	18.5	17.7	14.9	14.8	14.8
BENEFIT OF COLLEGE IS MONETARY	504.	48.2	29.8	42.7	61.8	46.3	54.1
STUDENTS HELP EVALUATE FACULTY	499.	80.3	86.6	82.2	76.2	76.7	76.5
ABOLISH COLLEGE GRADES	493.	39.4	41.9	40.2	42.2	44.8	43.5
DE-EMPHASIZE ORGANIZED SPORTS	500.	22.6	22.0	22.4	25.4	23.9	24.7
REGULATE STUDENT PUBLICATIONS	499.	19.7	18.8	19.4	30.9	31.6	31.3
COLLEGE HAS RIGHT TO BAN SPEAKER	503.	19.3	14.6	17.9	28.7	23.3	26.0
GIVE DISADVANTAGED PREF TRTMT	499.	33.8	24.0	30.9	40.3	38.1	39.2
COL TOO LAX ON STUDENT PROTEST	495.	42.2	44.9	43.0	49.2	42.8	46.0
ADOPT OPEN ADMISSIONS AT PUB COL	501.	21.4	13.3	19.0	32.6	32.3	32.5
USE SAME DEGREE STANDARD FOR ALL	497.	81.9	80.5	81.5	78.0	78.3	76.7
CURRENT POLITICAL PREFERENCE	497.						
FAR LEFT		3.2	.0	2.2	3.6	2.2	2.9
LIBERAL		43.2	27.3	38.4	38.0	33.9	35.9
MIDDLE-OF-THE-ROAD		36.3	52.7	41.2	41.4	49.2	45.3
CONSERVATIVE		17.3	20.0	18.1	16.1	14.4	15.3
FAR RIGHT		.0	.0	.0	.9	.3	.6
OBJECTIVES CONSIDERED TO BE ESSENTIAL OR VERY IMPORTANT							
ACHIEVE IN A PERFORMING ART	505.	14.2	26.3	17.8	11.4	16.0	13.7
BE AN AUTHORITY IN MY FIELD	505.	60.6	55.3	59.0	66.5	56.2	61.4
OBTAIN RECOGNITION FROM PEERS	505.	43.9	28.3	39.2	43.9	32.7	38.3
INFLUENCE POLITICAL STRUCTURE	504.	22.2	9.9	18.5	19.7	11.5	15.6
INFLUENCE SOCIAL VALUES	503.	31.8	29.1	31.0	29.3	31.9	30.6
RAISE A FAMILY	503.	62.8	70.2	65.0	58.5	65.3	61.9
HAVE ACTIVE SOCIAL LIFE	502.	59.1	44.0	54.6	57.7	51.9	54.8
HAVE FRIENDS DIFFERENT FROM ME	504.	62.5	70.4	64.9	58.6	65.2	61.9
BE AN EXPERT IN FINANCE	503.	14.5	2.6	10.9	19.2	6.2	12.2
BE ADMINISTRATIVELY RESPONSIBLE	503.	22.2	6.6	17.5	26.1	12.3	19.2
BE VERY WELL-OFF FINANCIALLY	504.	40.8	22.5	35.3	47.9	26.2	37.0
HELP OTHERS IN DIFFICULTY	503.	66.5	76.8	69.6	58.3	73.7	66.0
PARTICIPATE IN PEACE CORPS/VISTA	505.	14.4	26.3	18.0	12.3	23.7	18.0
BECOME A COMMUNITY LEADER	504.	22.2	9.9	18.5	19.8	11.5	18.7
CONTRIBUTE TO SCIENTIFIC THEORY	505.	11.3	5.3	9.5	12.3	5.5	8.9
WRITE ORIGINAL WORKS	505.	13.6	19.7	15.4	12.9	16.7	14.8
NEVER BE OBLIGATED TO PEOPLE	503.	19.7	14.5	18.1	21.8	19.3	20.6
CREATE WORKS OF ART	505.	10.2	21.1	13.5	10.6	20.9	18.7
KEEP UP WITH POLITICAL AFFAIRS	505.	59.5	52.0	57.2	48.8	42.1	45.5
SUCCEED IN MY OWN BUSINESS	503.	49.7	20.5	41.0	49.8	27.2	38.5
HELP CLEAN UP ENVIRONMENT	501.	49.7	51.0	50.1	44.9	43.0	44.0
DEVELOP A PHILOSOPHY OF LIFE	504.	76.7	86.2	79.6	68.7	76.2	72.5
PARTICIPATE IN COMMUNITY ACTION	505.	31.2	32.2	31.5	26.6	31.1	28.9
MARRY WITHIN NEXT 5 YEARS	505.	21.5	23.7	22.2	23.8	34.1	29.0

ITEM DESCRIPTION	NUMBER OF RESPONDENTS	Name of Institution			4-YR COLLEGES NATL NORMS		
		MALE	FEMALE	TOTAL	MALE	FEMALE	TOTAL
(PERCENTAGES)							
SELF RATINGS OF BETTER THAN 'AVERAGE' ON PERSONAL TRAITS							
ACADEMIC ABILITY	503.	74.4	84.2	77.3	56.5	56.0	56.2
ATHLETIC ABILITY	504.	51.7	34.2	46.4	49.1	24.6	36.8
ARTISTIC ABILITY	504.	15.6	23.7	18.1	15.5	19.8	17.6
CHEERFULNESS	504.	52.6	51.3	52.2	50.1	56.8	53.4
DEFENSIVENESS	498.	21.1	25.0	22.3	26.7	27.1	26.9
DRIVE TO ACHIEVE	503.	55.8	68.4	59.6	55.0	56.2	55.6
LEADERSHIP ABILITY	504.	44.9	41.4	43.8	44.1	32.0	38.0
MATHEMATICAL ABILITY	505.	39.7	44.1	41.0	40.2	26.4	33.3
MECHANICAL ABILITY	505.	23.2	13.2	20.2	31.7	8.3	20.0
ORIGINALITY	504.	35.5	41.4	37.3	37.0	35.5	36.2
POLITICAL CONSERVATISM	498.	16.7	15.2	16.3	12.1	7.5	9.8
POLITICAL LIBERALISM	497.	35.3	22.1	31.4	28.0	20.8	24.4
POPULARITY (GENERAL)	505.	39.1	28.9	36.0	36.1	27.0	31.6
POPULARITY WITH OPPOSITE SEX	505.	30.3	30.3	30.3	33.6	23.7	28.7
PUBLIC SPEAKING ABILITY	503.	25.9	22.5	24.9	25.2	18.5	21.9
SELF-CONFIDENCE (INTELLECTUAL)	505.	41.9	46.1	43.2	43.3	32.1	37.7
SELF-CONFIDENCE (SOCIAL)	503.	30.2	19.7	27.0	33.2	24.8	29.0
SENSITIVITY TO CRITICISM	505.	31.2	39.5	33.7	23.7	29.7	26.7
STUBBORNNESS	503.	33.6	37.5	34.8	35.9	37.4	36.7
UNDERSTANDING OF OTHERS	503.	70.9	73.7	71.8	61.4	68.9	65.1
WRITING ABILITY	505.	37.7	43.4	39.4	30.2	31.0	30.6
STUDENTS ESTIMATE CHANCES ARE VERY GOOD THAT THEY WILL							
GET MARRIED WHILE IN COLLEGE	504.	3.4	3.9	3.6	7.5	10.0	8.7
MARRY WITHIN A YEAR AFTER COL	503.	18.5	25.8	20.7	19.9	23.2	21.6
VOTE IN 1972 PRES ELECTION	503.	85.8	78.1	83.5	77.1	78.0	77.5
ENLIST IN ARMED SERV BEFORE GRAD	503.	.3	.7	.4	5.3	.3	2.8
CHANGE MAJOR FIELD	501.	18.0	22.5	19.4	13.1	15.2	14.1
CHANGE CAREER CHOICE	497.	20.9	27.0	22.7	13.2	15.5	14.3
FAIL ONE OR MORE COURSES	504.	1.4	1.3	1.4	2.8	1.9	2.4
GRADUATE WITH HONORS	503.	4.0	8.6	5.4	5.8	4.2	5.0
BE ELECTED TO A STUDENT OFFICE	503.	2.6	4.0	3.0	2.1	1.1	1.6
JOIN SOC FRATERNITY OR SORORITY	503.	33.4	32.0	33.0	15.7	17.9	16.8
BE ELECTED TO AN HONOR SOCIETY	500.	2.3	8.7	4.2	3.5	3.7	3.6
MAKE AT LEAST A 'B' AVERAGE	500.	28.9	39.3	32.0	23.7	24.6	24.1
NEED EXTRA TIME TO GET DEGREE	504.	1.1	4.0	2.0	3.5	3.2	3.4
WORK AT OUTSIDE JOB	503.	16.5	20.5	17.7	27.2	30.2	28.7
SEEK VOCATIONAL COUNSELING	505.	16.1	24.3	18.6	11.6	13.9	12.7
SEEK PERSONAL COUNSELING	504.	9.1	8.6	8.9	8.3	7.5	7.9
ENROLL IN HONORS COURSE	499.	3.7	13.9	6.8	6.3	6.2	6.3
GET TUTORING HELP IN COURSES	500.	6.0	6.6	6.2	7.9	7.3	7.6
AUTHOR A PUBLISHED ARTICLE	496.	4.6	6.7	5.2	4.9	4.1	4.5
BE MORE SUCCESSFUL THAN MOST	498.	8.4	2.6	6.6	11.3	5.1	8.2
DROP OUT TEMPORARILY	501.	2.0	.0	1.4	1.5	1.7	1.6
DROP OUT PERMANENTLY	497.	.3	.7	.4	.8	1.1	.9
TRANSFER TO ANOTHER COLLEGE	503.	5.7	7.9	6.4	10.2	12.7	11.5
BE SATISFIED WITH MY COLLEGE	501.	59.1	70.2	62.5	54.3	62.3	58.3

AMERICAN COUNCIL ON EDUCATION OFFICE OF RESEARCH
SUMMARY OF DATA ON ENTERING FRESHMEN
(FALL 1971)

Name of Institution

PAGE 8 OF 8

ITEM DESCRIPTION	NUMBER OF RESPONDENTS	Name of Institution			4-YR COLLEGES NAT'L NORMS		
		MALE	FEMALE	TOTAL	MALE	FEMALE	TOTAL
(PERCENTAGES)							
ACTIVITIES ENGAGED IN BY STUDENTS DURING THE PAST YEAR							
VOTED IN STUDENT ELECTION (3)	502.	64.4	70.2	66.1	64.2	71.0	67.6
CAME LATE TO CLASS	504.	60.8	55.9	59.3	55.4	52.9	54.2
PLAYED A MUSICAL INSTRUMENT	504.	40.9	59.2	46.4	38.4	44.6	40.5
STUDIED IN THE LIBRARY (3)	501.	29.1	40.4	32.5	29.4	37.6	33.5
CHECKED OUT A LIBRARY BOOK (3)	504.	40.1	64.5	47.4	38.2	53.7	45.9
ARRANGED DATE FOR STUDENT	503.	38.7	35.5	37.8	44.6	39.6	42.1
OVERSLEPT AND MISSED A CLASS	503.	21.9	14.5	19.7	24.1	17.0	20.6
READ ABOUT RIGHTS/RESPONSIBILITY	502.	66.6	75.0	69.1	66.4	74.5	70.5
TYPED A HOMEWORK ASSIGNMENT (3)	503.	20.2	27.0	22.3	17.5	29.6	23.5
DISCUSSED FUTURE WITH PARENTS(3)	503.	40.2	46.1	41.9	34.7	47.4	41.1
WAS LATE WITH SCHOOL ASSIGNMENT	502.	70.4	54.3	65.5	72.7	61.1	66.9
ARGUED WITH A TEACHER IN CLASS	501.	58.7	49.3	55.9	57.2	44.3	50.8
ATTENDED A RELIGIOUS SERVICE	501.	86.6	96.0	89.4	86.2	90.8	88.5
DEMONSTRATED FOR RACIAL CHANGE	503.	18.2	6.6	14.7	19.0	15.6	17.3
DEMONSTRATED FOR MILITARY CHANGE	503.	16.8	7.3	13.7	14.3	10.4	12.3
DEMONSTRATED FOR SCHOOL CHANGE	504.	37.5	35.5	36.9	35.5	32.9	34.2
DID EXTRA READING FOR COURSE (3)	502.	9.7	23.2	13.7	13.4	18.4	15.9
TOOK SLEEPING PILLS	504.	3.4	7.9	4.8	3.6	4.9	4.3
TUTORED ANOTHER STUDENT	504.	46.9	75.0	55.4	45.0	50.6	47.8
PLAYED CHESS	502.	49.9	25.2	42.4	53.8	23.6	38.7
READ POETRY NOT REQUIRED	503.	50.7	85.5	61.2	50.1	78.4	64.2
TOOK A TRANQUILIZING PILL	503.	3.4	6.6	4.4	4.3	8.5	6.4
DISCUSSED RELIGION (3)	504.	23.3	40.8	28.6	24.1	35.1	29.6
TOOK VITAMINS	504.	61.1	65.1	62.3	56.9	63.7	60.3
VISITED ART GALLERY OR MUSEUM	502.	70.3	84.9	74.7	63.2	71.9	67.5
PARTICIPATED IN H.S. POL. CMPG.	501.	38.1	44.1	39.9	39.6	41.0	40.3
PARTICIPATED IN OTHER POL.CMPG.	502.	16.0	13.2	15.1	14.0	15.5	14.8
MISSED SCHOOL DUE TO ILLNESS (3)	504.	.6	3.3	1.4	1.9	4.7	3.3
SMOKED CIGARETTES (3)	504.	9.4	6.6	8.5	14.5	11.7	13.1
DISCUSSED POLITICS (3)	504.	33.0	22.4	29.8	26.6	19.5	23.0
DRANK BEER	503.	77.5	37.5	65.4	68.9	46.1	57.5
DISCUSSED SPORTS (3)	505.	61.5	32.2	52.7	58.1	28.9	43.5
READ ABOUT CIVIL RIGHTS	504.	86.4	82.9	85.3	82.8	83.0	82.9
ASKED TEACHER FOR ADVICE (3)	504.	29.3	39.5	32.3	23.0	26.4	24.7
HAD VOCATIONAL COUNSELING	503.	36.9	45.7	39.6	46.1	49.5	47.3
STAYED UP ALL NIGHT	504.	58.0	57.9	57.9	60.7	60.2	60.5

(*)

TOTAL NUMBER OF VALID FORMS RECEIVED BY AGE IS INDICATED BY THE FIRST NUMBER IN THIS COLUMN.

(**)

THIS ITEM IS REPORTED FOR THE FIRST TIME IN 1971. ITEMS NOT INDICATED WITH '**' ARE REPEATED OR MODIFIED QUESTIONS FROM ONE OR MORE OF THE EARLIER SURVEYS.

(1)

SINCE IT IS POSSIBLE THAT SOME STUDENTS MAY HAVE CHECKED MORE THAN ONE RESPONSE CATEGORY FOR THIS ITEM, THE PERCENTAGES MAY SUM TO MORE THAN 100.

(2)

RECATEGORIZATION OF THIS ITEM FROM A LONGER LIST IS SHOWN IN APPENDIX C OF THE 1971 NAT'L NORMS REPORT.

(3)

FREQUENTLY ONLY, ALL OTHER ITEMS FREQUENTLY PLUS OCCASIONALLY.

Name of Institution

AMERICAN COUNCIL ON EDUCATION OFFICE OF RESEARCH
SUMMARY OF DATA ON ENTERING FRESHMEN
(FALL 1971)

OPTIONAL ITEMS
PAGE 1 OF 2

ITEM DESCRIPTION	NUMBER OF RESPONDENTS	Name of Institution (PERCENTAGES)		
		MALE	FEMALE	TOTAL
QUESTION 30	0.			
RESPONSE A		.0	.0	.0
RESPONSE B		.0	.0	.0
RESPONSE C		.0	.0	.0
RESPONSE D		.0	.0	.0
RESPONSE E		.0	.0	.0
QUESTION 31	0.			
RESPONSE A		.0	.0	.0
RESPONSE B		.0	.0	.0
RESPONSE C		.0	.0	.0
RESPONSE D		.0	.0	.0
RESPONSE E		.0	.0	.0
QUESTION 32	0.			
RESPONSE A		.0	.0	.0
RESPONSE B		.0	.0	.0
RESPONSE C		.0	.0	.0
RESPONSE D		.0	.0	.0
RESPONSE E		.0	.0	.0
QUESTION 33	0.			
RESPONSE A		.0	.0	.0
RESPONSE B		.0	.0	.0
RESPONSE C		.0	.0	.0
RESPONSE D		.0	.0	.0
RESPONSE E		.0	.0	.0
QUESTION 34	0.			
RESPONSE A		.0	.0	.0
RESPONSE B		.0	.0	.0
RESPONSE C		.0	.0	.0
RESPONSE D		.0	.0	.0
RESPONSE E		.0	.0	.0

NOTE--IGNORE THIS PAGE IF YOU DID NOT REQUEST SUPPLEMENTAL QUESTIONS OF YOUR FRESHMEN.

Name of Institution

AMERICAN COUNCIL ON EDUCATION OFFICE OF RESEARCH
SUMMARY OF DATA ON ENTERING FRESHMEN
(FALL 1971)

OPTIONAL ITEMS
PAGE 2 OF 2

ITEM DESCRIPTION	NUMBER OF RESPONDENTS	Name of Institution		
		MALE	FEMALE	TOTAL
QUESTION 35	0.			
RESPONSE A		.0	.0	.0
RESPONSE B		.0	.0	.0
RESPONSE C		.0	.0	.0
RESPONSE D		.0	.0	.0
RESPONSE E		.0	.0	.0
QUESTION 36	0.			
RESPONSE A		.0	.0	.0
RESPONSE B		.0	.0	.0
RESPONSE C		.0	.0	.0
RESPONSE D		.0	.0	.0
RESPONSE E		.0	.0	.0
QUESTION 37	0.			
RESPONSE A		.0	.0	.0
RESPONSE B		.0	.0	.0
RESPONSE C		.0	.0	.0
RESPONSE D		.0	.0	.0
RESPONSE E		.0	.0	.0
QUESTION 38	0.			
RESPONSE A		.0	.0	.0
RESPONSE B		.0	.0	.0
RESPONSE C		.0	.0	.0
RESPONSE D		.0	.0	.0
RESPONSE E		.0	.0	.0
QUESTION 39	0.			
RESPONSE A		.0	.0	.0
RESPONSE B		.0	.0	.0
RESPONSE C		.0	.0	.0
RESPONSE D		.0	.0	.0
RESPONSE E		.0	.0	.0

NOTE--IGNORE THIS PAGE IF YOU DID NOT REQUEST SUPPLEMENTAL QUESTIONS OF YOUR FRESHMEN.



